



Harley-Davidson Street Glide and Road Glide 2014-2022 Infinity and Saddle Tramp two speaker kit

Visit metraonline.com to view the available installation parts and Motorcycle accessories. Not compatible with the Rockford Fosgate OE system.

KIT FEATURES

- Kappa Perfect 6.5" speakers
- All installation equipment provided
- For 2014-2022 Harley Davidson Street and Road Glide motorcycle fairings

WHAT'S IN THE BOX

- A) One 4 Channel Kappa Perfect Amplifier • B) One pair of Kappa Perfect 600x • C) Saddle Tramp DSP/Interface
- D) Street and Road Glide Amplifier brackets • E) Plug-n-Play Harnessing • F) Dual Amplifier power harness

TOOLS REQUIRED

- Panel removal tool • Phillips screwdriver • Allen wrenches (5/32" and 3/16") • Torx sockets (T25, T27, T40)
- Socket set (7/16" short and deep well)

TABLE OF CONTENTS

Fairing disassembly	
Street Glide	2-4
Road Glide	5-6
Fuel tank removal.....	7-8
Speaker pod assembly	
Street Glide	9
Road Glide	10
Harness routing and installation.....	11
Amplifier mount	
Street Glide	12-13
Road Glide	14
Wire routing.....	15-18
Amp bypass installation plugs	19

Attention! With the key out of the ignition, disconnect the negative battery terminal before installing this product. Ensure that all installation connections are secure before cycling the ignition to test this product.

FAIRING DISASSEMBLY (STREET GLIDE)

Attention! It is recommended that any OEM amplifiers and harnessing be removed from the bike before starting the installation of the Infinity audio system. These systems are designed to unplug from factory connectors. The removal of the OE equipment will be easier after the disassembly steps are completed. **DO NOT CUT FACTORY HARNESSES.**** If your motorcycle has an amplified BOOM system we have included amp bypass plugs in circumstances when removing the OE equipment is not an option. Please see the Amp Bypass section of this manual for installation details.

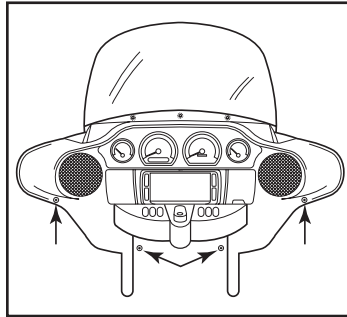

(Figure A)

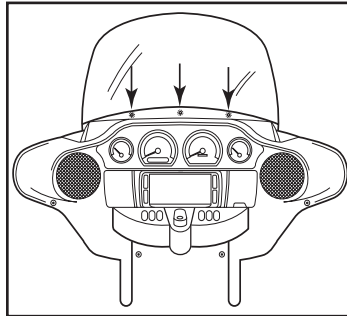

(Figure B)

Harley Davidson Street Glide, Electra Glide, Ultra, and Limited models 2014-2022

1. Remove (4) T-27 Torx screws from the inner fairing. (Figure A)
2. With a firm grip on the windshield, remove (3) T-27 Torx screws. Remove the windshield, the outer fairing will also be loosened. (Figure B)
3. Remove the outer fairing, unplugging the headlight. (Figure C)
4. Remove (2) T-27 Torx screws to remove the fairing vent, and then remove the vent. (Figure D)

Continued on next page

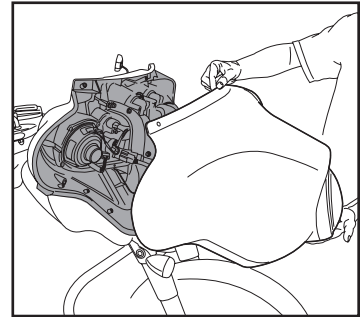

(Figure C)

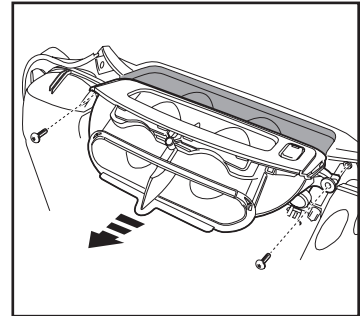

(Figure D)

FAIRING DISASSEMBLY (STREET GLIDE) (CONT.)

Radio Upper Support Bracket removal

1. Remove (4) T-25 securing the radio support bracket to the radio. (Figure E)
2. Remove (4) 5/32 Allen screws securing the radio support bracket to each speaker pod. (Figure E)
3. Remove (1) T-25 on the brake side under the radio support bracket. (Figure E)
4. Release all wiring attached to the bracket and remove, exposing the radio chassis.

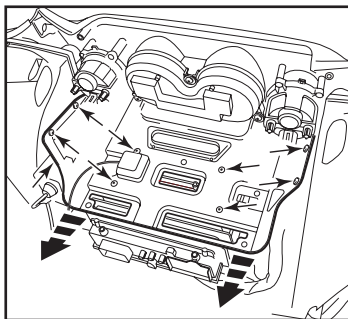

(Figure E)

Radio Removal

1. Unplug all harnessing from the radio (Figure F)
2. Remove (4) 3/16 Allen screws securing the radio to bike chassis.
3. Using a Phillips screw driver remove the (2) plastic push pins from the panel directly under the radio location. This will expose the bolt to be removed in the next step. (Figure G)
4. If the bike is equipped with other communication modules, they will need to be removed to gain access to the OE mounting bolts.

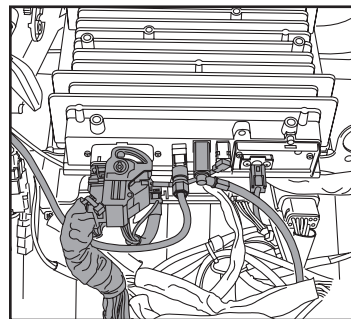

(Figure F)

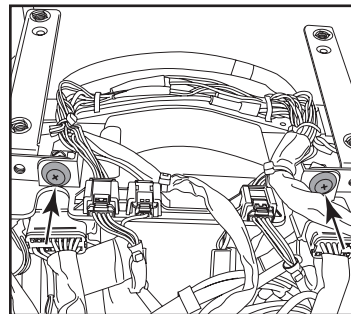

(Figure G)

Continued on next page

FAIRING DISASSEMBLY (STREET GLIDE) (CONT.)

Speaker Pod Removal

1. Remove (3) 3/16 Allen screws securing the speaker pods to the front fairing. (Figure H)
2. Below the radio location, inside the fairing brackets are (3) 7/16 bolts used to secure each pod to the fairing support. Using a socket and ratchet remove all bolts. (Figure I)
3. Remove each speaker pod and set aside.
4. Using a T-25 remove the screws that hold the original speaker grille in place. (Figure J)

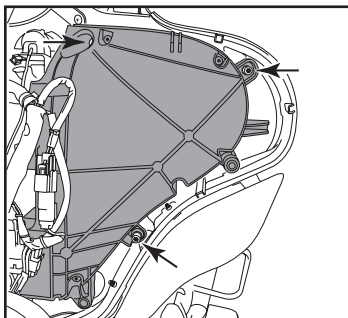

(Figure H)

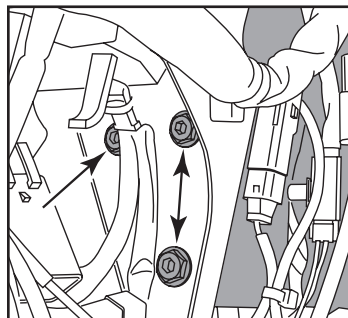

(Figure I)

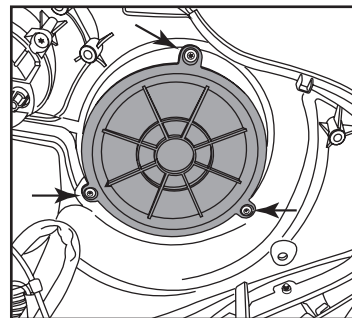

(Figure J)

*Continue to Fuel Tank Removal
on page 7*

FAIRING DISASSEMBLY (ROAD GLIDE)

Attention! It is recommended that any OEM amplifiers and harnessing be removed from the bike before starting the installation of the Infinity audio system. These systems are designed to unplug from factory connectors. The removal of the OE equipment will be easier after the disassembly steps are completed. **DO NOT CUT FACTORY HARNESSES.**** If your motorcycle has an amplified BOOM system we have included amp bypass plugs in circumstances when removing the OE equipment is not an option. Please see the Amp Bypass section of this manual for installation details.

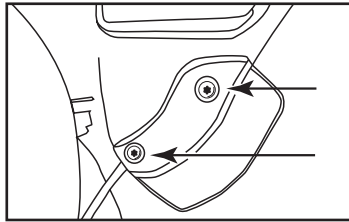

(Figure A)

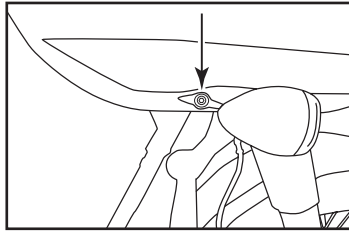

(Figure B)

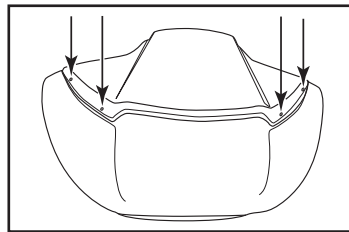

(Figure C)

1. Remove the lower T-27 Torx screws holding the deflector wings, one on either side. **Note:** Only the lower (2) need to be removed. (Figure A)
2. Remove (1) 3/16" Allen screw securing each turn signal. (Figure B)
3. With a firm grip on the windshield, remove (4) Phillips screws and set the windshield aside. (Figure C)
4. Remove the top fairing trim clipped to the top of the radio. (Figure D)
5. Unplug the turn signals.
6. Remove the speaker grills with a panel removal tool and remove (1) T-30 Torx screw from each side. (rg sp 1) (Figure E)

CAUTION: The fairing will be loose at this point. Have a helper hold it to keep from damaging it when removing the screws.

7. Remove the fairing and set aside.
8. Unplug radio

Continued on next page

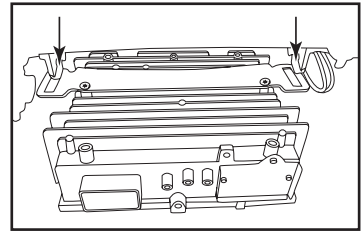

(Figure D)

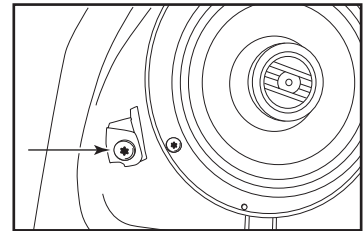

(Figure E)

FAIRING DISASSEMBLY (ROAD GLIDE) (CONT.)

Remove factory speaker

1. Remove (4) T-25 Torx screws from each speaker. (Figure F)
2. Disconnect the OE speakers

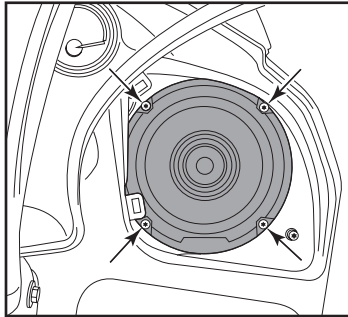

(Figure F)

Remove Headlight Housing (Amp bracket installation)

1. Remove the plastic headlight trim brackets using T-25 Torx bit.
2. Remove the (4) bolts holding the headlight housing in place. Two bolts on the top and two on the bottom. (Figure G)
3. Slide headlight housing out of the bike and unplug the connector. **Note:** hold headlight in place while removing the last bolt.

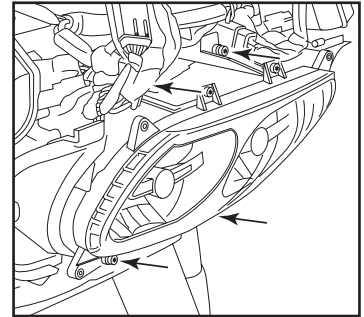

(Figure G)

*Continue to Fuel Tank Removal
on page 7*

FUEL TANK REMOVAL

Fuel Tank Removal

1. Using a Philips screw driver remove the bolt holding the seat to the rear fender.
2. If the seat has a strap separating the rider and passenger seat you will need to remove (2) Philips screws from either side of the seat. Open each bag lid to gain access to the screw.
3. Pull up and back on the seat to release the front of the seat, set aside.
4. Remove the (2) plastic covers to expose the T-40 bolts and remove. (Figure A)
5. Remove (2) T-40 bolts at the base of the gas tank, under the seat. (Figure B)

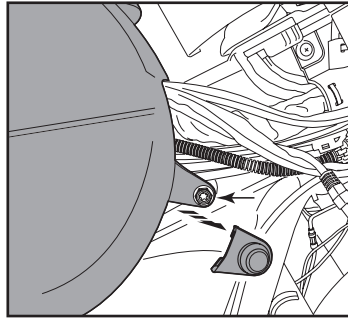

(Figure A)

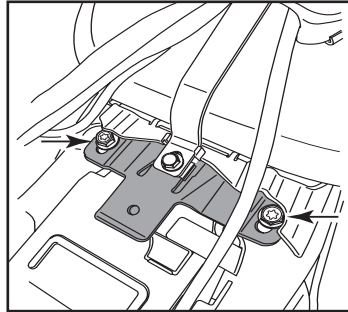

(Figure B)

6. Unplug and disconnect all connectors and drain tubes that would prevent gas tank removal. (Figure C)
7. Disconnect the fuel supply line. The quick disconnect can be found on the clutch side of the gas tank. Push up on the silver collar and pull down slightly on the hose. The fuel line will release. A small amount of fuel that will be release while disconnecting. Once disconnected the gas will not leak out. (Figure D)

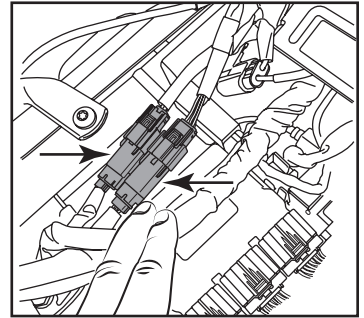

(Figure C)

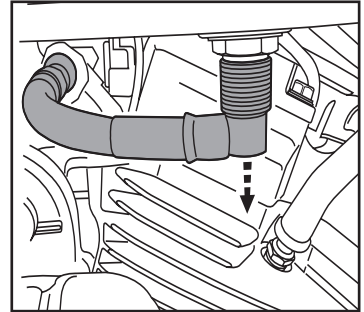

(Figure D)

Continued on next page

FUEL TANK REMOVAL (CONT.)

Fuel Tank Removal (cont.)

8. Set gas tank aside to gain access to the back bone wire harness channel. (Figure E)
9. Remove the plastic cover by releasing the locking tab up both sides of the plastic channel. (Figure E)

Continue to Speaker Pod Assembly

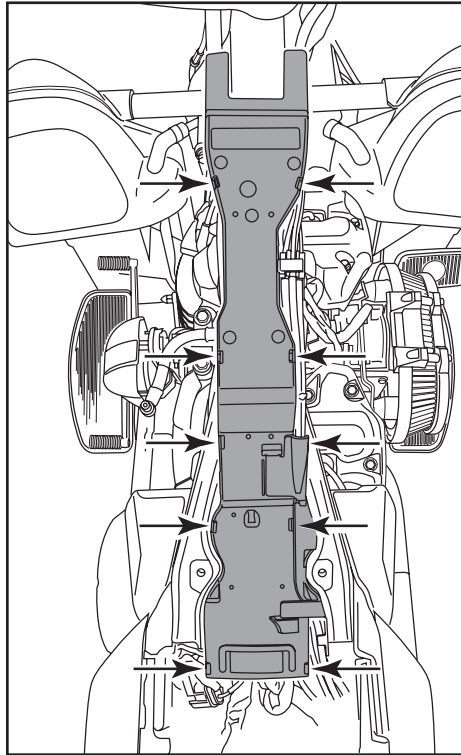

(Figure E)

SPEAKER POD ASSEMBLY (STREET GLIDE)

Speaker Pod Assembly

1. Remove the OE speakers from each speaker pod using a T-25 Torx. Unplug the speaker and set aside. **Note:** the smaller speaker terminal is the positive (+) speaker lead, the larger terminal is the negative (-). (Figure A)
2. From the 600x Kappa Perfect Box remove **6.5" speakers and grilles** (F) and (G).
3. Using the supplied speaker wire connect the OE speaker terminals to the **Infinity speaker wires** labeled IN+ and IN-. (Figure B)
4. Connect the W+ and W- to the woofer speaker terminals. Then connect the T+ and T- to the tweeter speaker terminals. (Figure C)

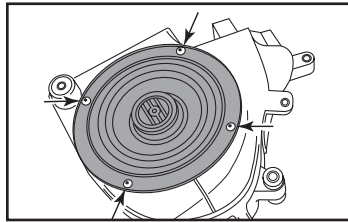

(Figure A)

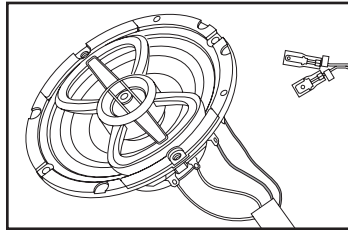

(Figure B)

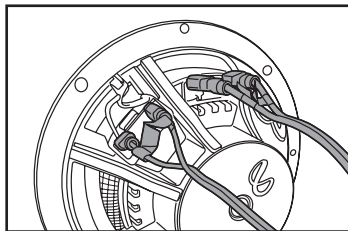

(Figure C)

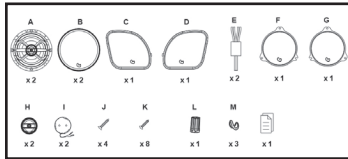

5. Each speaker pod has an alignment pin that matches up with the **kappa perfect 6.5" speaker**. Using the supplied Phillips screws secure the speakers into each pod. Do not over tighten, the screws could strip the plastic. (Figure D)
6. Install **grille** (F) and (G) using the OE hardware. Grilles mount from the back, the indent for the Infinity sticker should be at the bottom of the speakers opening. (Figures E, F)
7. Reinstall the speaker pods in reverse order.

Continue to Harness Routing and Installation

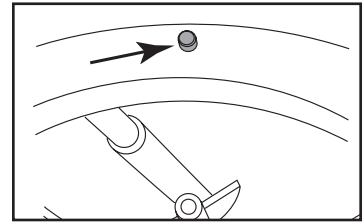

(Figure D)

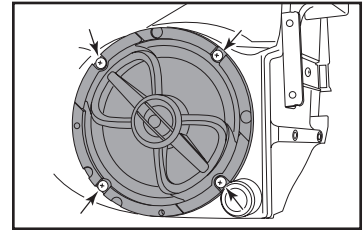

(Figure E)

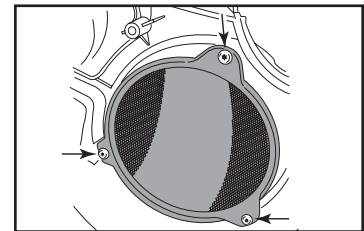

(Figure F)

SPEAKER POD ASSEMBLY (ROAD GLIDE)

Speaker Pod Assembly

1. From the 600x Kappa Perfect Box remove **6.5" speakers and grilles** (F) and (G).
2. Using the supplied speaker wire connect the OE speaker terminals to the **Infinity speaker wires** labeled IN+ and IN- (Figure A)
3. Connect the W+ and W- to the woofer speaker terminals. Then connect the T+ and T- to the tweeter speaker terminals. (Figure B)

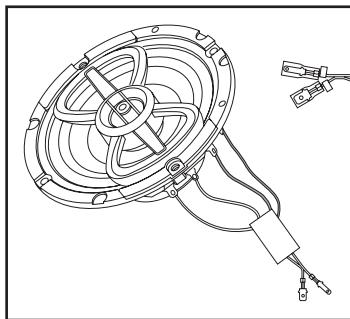

(Figure A)

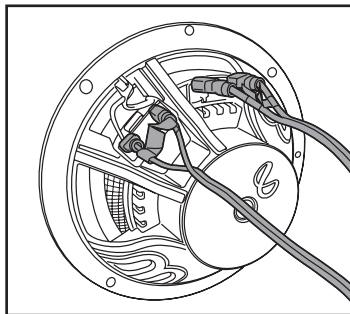

(Figure B)

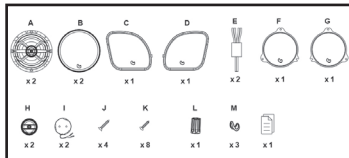

4. Each speaker pod has an alignment pin that matches up with the **kappa perfect 6.5" speaker**. Using the supplied Phillips screws secure the speakers into each pod. Do not over tighten, the screws could strip the plastic. (Figure C)
5. Install **grille** (C) and (D) using the OE hardware. Grilles mount from the back, the indent for the Infinity sticker should be at the bottom of the speakers opening. (Figure D)

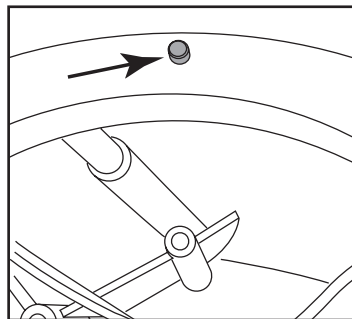

(Figure C)

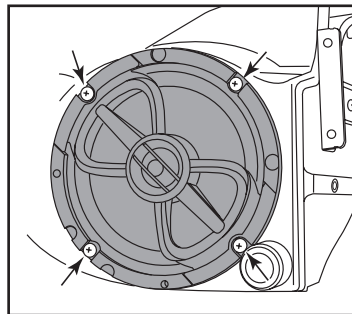

(Figure D)

Continue to Harness Routing and Installation

HARNESS ROUTING AND INSTALLATION

HM-9703 Dual Amp Harness

1. Route the **dual amp harness** up the back bone channel into the fairing. The (2) 3-position plugs should be routed to the inside the fairing. The Power and Ground ring terminals should connect directly to the motorcycles battery. Secure the fuse holder with zip-ties. (Figure A)

Continued to Amplifier Mount

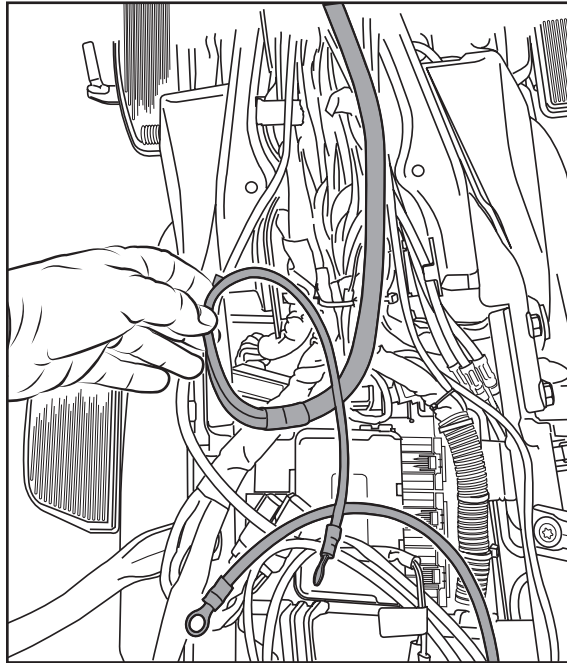

(Figure A)

AMPLIFIER MOUNT (STREET GLIDE)

Radio and amp bracket assembly

1. Reinstall the plastic plate located under the radio chassis. Reinstall push pins to secure. (Figure A)
2. Reinstall the OE radio, secure using the original 3/16th Allen screws. (Figure B)
3. Leave radio connectors unplugged.

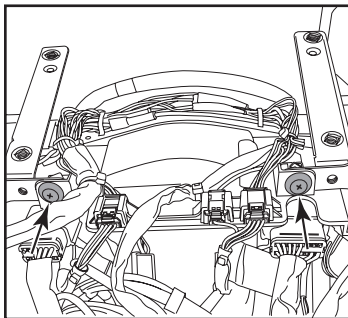

(Figure A)

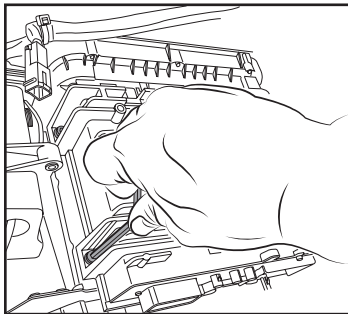

(Figure B)

4. Reinstall and secure the upper support bracket to the speaker pods and the single T-25 Torx under the support bracket. (Figure C)
5. Install the **BC-AMP06** on top of the upper support bracket. Use the original (4) T-25 screws to secure the amp bracket through the OE support bracket into the radio's chassis. (Figure D)

Continued on next page

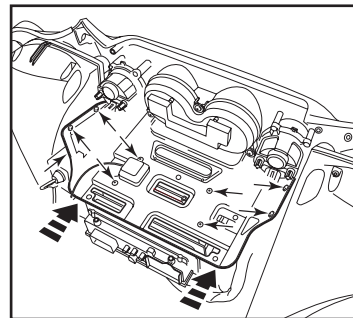

(Figure C)

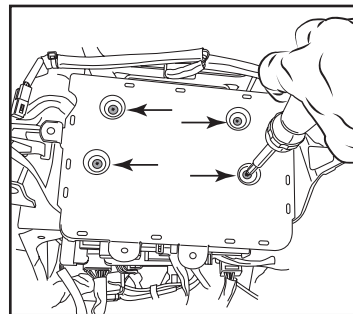

(Figure D)

AMPLIFIER MOUNT (STREET GLIDE) (CONT)

Radio and Amp Bracket Assembly (cont.)

- Use the supplied **hook and loop pad**, peel one side and apply to the surface of the **BC-AMP06**. Stick the hook and loop together and peel the second side. (Figures E, F)
- The tabs hanging over the front edge of the **AMP06 bracket** are used to mount the OE connectors. (Figure G)

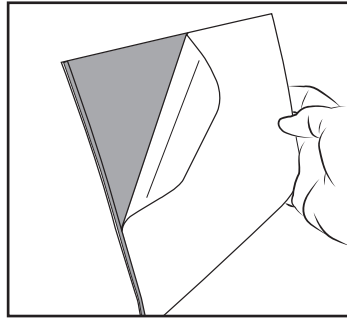

(Figure E)

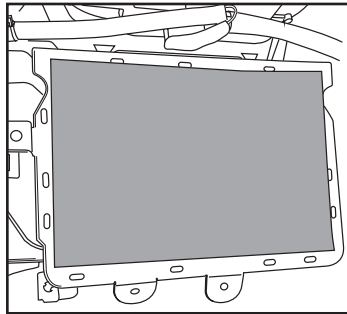

(Figure F)

- Remove the **Kappa Perfect amplifier**. Access the gain and crossover adjustments by removing the watertight cover on the input side of the **KP5004** amp. Using the image confirm the amp is properly configured.
 - Input Level – Set to LO
 - Front and Rear Levels – Set to 25% or 9 o'clock
 - Front and Rear Crossover – Set to off (Figure H)
- Replace the watertight cover.
- Position the Infinity amp power and speaker connectors on the clutch side of the **BC-AMP06 bracket**. Place the amp against the back of the gauge cluster and stick to the hook and loop. (Figure I)

Continue to Wire Routing

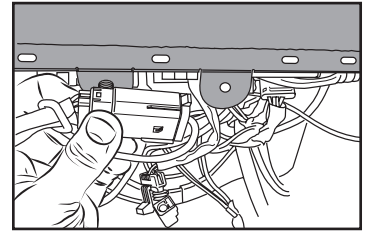

(Figure G)

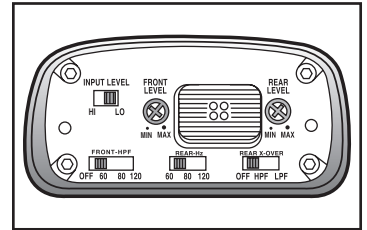

(Figure H)

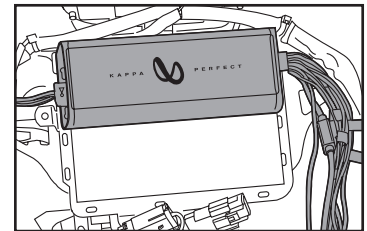

(Figure I)

AMPLIFIER MOUNT (ROAD GLIDE)

Amp Bracket Assembly

1. Remove the **BC-AMP04** from the box. Apply one side the **supplied hook and loop pad** to the area marked in image. Trim off overhanging material. (Figure A)
2. **Amp bracket** is installed in the open space below the radio. **Amp bracket** tabs should be pointed down as the bracket is slid into place. (Figures B, C)
3. Using the supplied 1/4-20 stainless bolts thread the bolts through the fairing stay bracket into the threaded inserts on the **BC-AMP04 bracket**, using 7/16 socket tighten bolts. (Figure D)

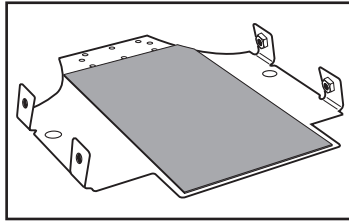

(Figure A)

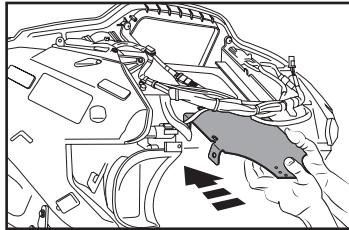

(Figure B)

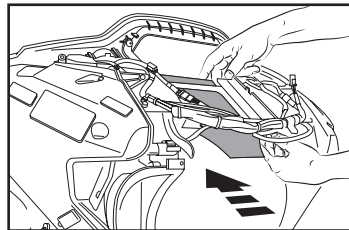

(Figure C)

4. Remove the **Kappa Perfect amplifier**. Access the gain and crossover adjustments by removing the watertight cover on the input side of the **KP5004** amp. Using the image confirm the amp is properly configured.
 - a. Input Level – Set to LO
 - b. Front and Rear Levels – Set to 25% or 9 o'clock
 - c. Front and Rear Crossover – Set to off (Figure E)
5. Replace the watertight cover.
6. Trim the remaining **hook and loop pad** to fit the bottom of the amp.
7. Orient the amplifier so the power and speaker output connectors are toward the front of the bike. Push the amplifier into the fairing and stick to the hook and loop pad on the **amp bracket**. (Figure F)
8. The wires should be hanging down and provide easy access when installing the **HM-9715 harness**.
Continue to Wire Routing

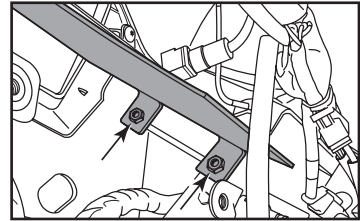

(Figure D)

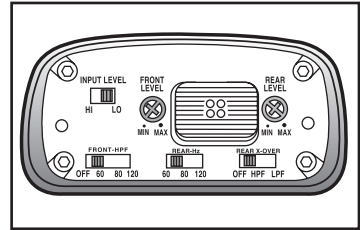

(Figure E)

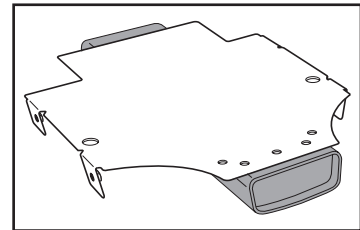

(Figure F)

WIRE ROUTING

Saddle Tramp Interface and DSP Assembly

1. Unsnap the cap from the case. Insert the over molded gaskets from the **HM-9715 harness** into the respective opening in the front of the cap, making sure the grommets are properly seated.
2. Slide the DSP board out of the case and plug in the 16 and 20 pin connectors. **Make sure the connectors are fully seated to the DSP board.**
3. Reinsert the DSP board into the case and snap the cap into place. The arrows on the cap should be pointed toward the Saddle Tramp logo on the case.
4. Find a secure mounting location for the DSP case. It is recommended that the cap be installed facing down. The zip-tie mounts on each side of the case can be used to secure the DSP into place. (Figure A)

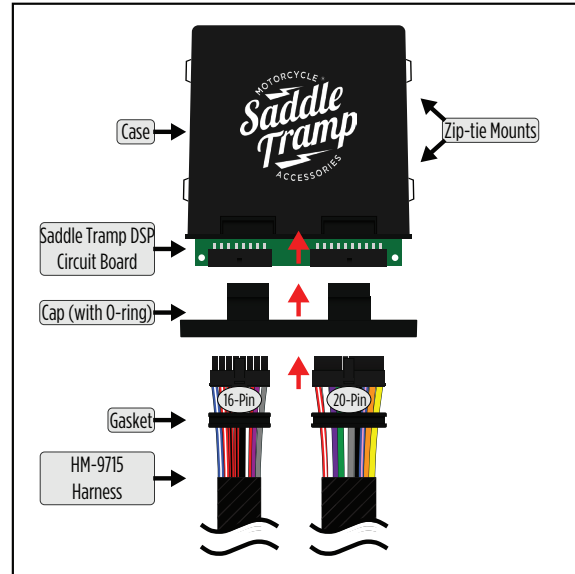

(Figure A)

WIRE ROUTING (CONT.)

Wiring up the radio (HM-9715)

1. Plug the connector from the **HM-9715 harness** into the OE radio, then plug the original radio connector into the **HM-9715 t-harness**. (Figures A,B,C,D)

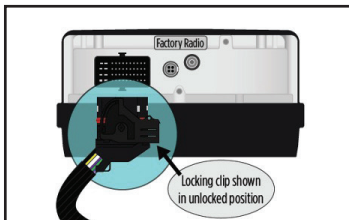

(Figure A)



(Figure B)



(Figure C)

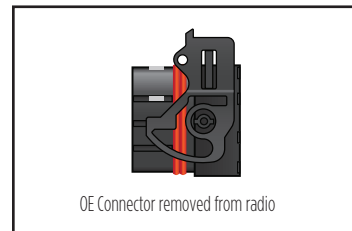

(Figure D)

Wiring up the radio (HM-9715) (cont.)

2. Infinity Amp connections
(See Figure E on page 18)
 - a. Plug the black 4 pin Molex connector labeled Front speakers from the HM-9715 harness into the Front Speaker output of the amplifier. Amplifier will power the fairing speakers.
 - b. Plug the HM-9703 3 Pin power connector into amplifier one.
 - c. From the 16 pin DSP harness. Plug the white 4 pin Molex connects labeled Ch1 & 2 into amplifier's front inputs.
 - d. Channels 3/4 are used when upgrading your system with additional amps and speakers.
3.
 - a. Channels 5/6 and CH7/8 are used when upgrading your system with additional Infinity amps and speakers.
 - b. Channels 9 & 10 are available as additional outputs and not typically used. Secure with zip-ties.
4. Connect the Blue/White wire from the 16 pin DSP harness to the Blue/White wire on the HM-9703 harness.

Continued on next page

WIRE ROUTING (CONT.)

Infinity Amp connections

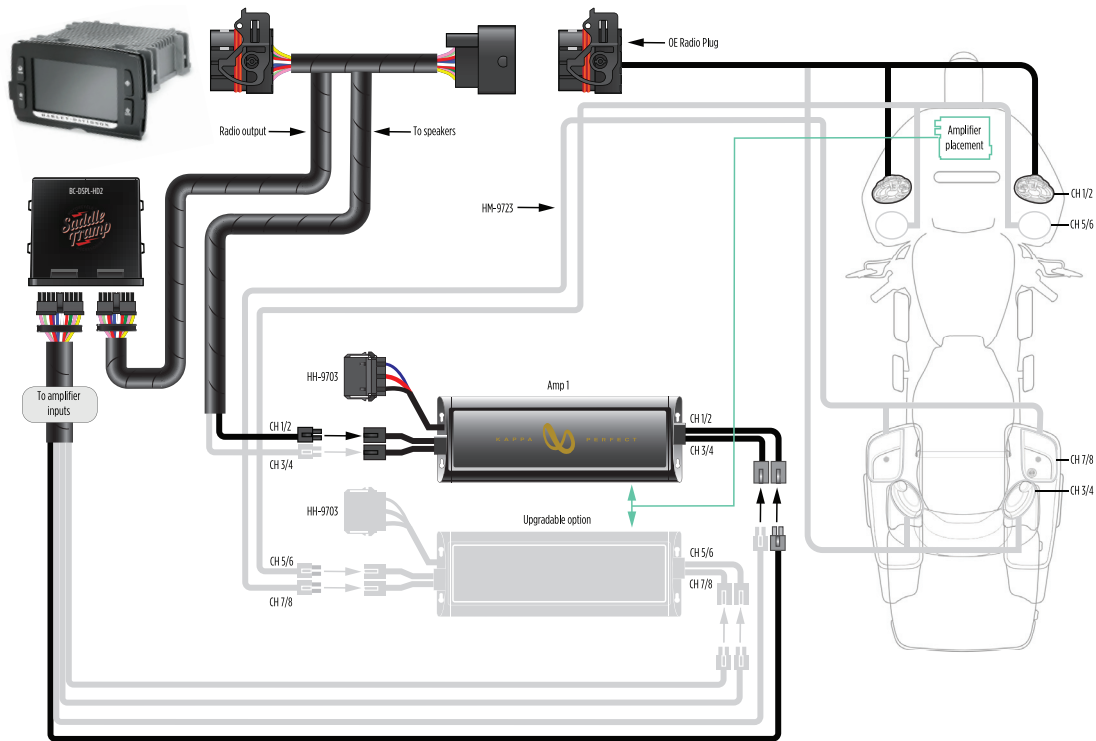

(Figure E)

Continued on next page

AMP BYPASS INSTALLATION PLUGS BC-9726

Front Amp Bypass plug

1. Unplug and remove the OE amp.
2. Plug the Front AMP bypass plug into the connector removed from OE amp.
3. This plug will loop the front speakers to back to the OE radio
4. Connected inside the Front speaker pods, you will find the speaker wires for the Front Woofers
5. Front Left (+) BN/O on one side of connector and PK on the side that connects to the speaker.
6. Front Left (-) BN/GY on one side of connector and PK/BK on the side that connects to the speaker.
7. Front Right (+) BN/R on one side of connector and PK on the side that connects to the speaker.
8. Front Right (-) BN/GN on one side of connector and PK/BK on the side that connects to the speaker.

Right (Brake Side) rear amp bypass plug

1. Unplug and remove OE amplifier from Right SaddleBag.
2. Plug in the Right Rear Bypass Plug into the connector removed from OE amp.
3. Connect the 900X Infinity wires to the two pin speaker connector for the RIGHT REAR WOOFER
4. If hard wiring is required the OE wire colors and polarity is below.
 - a. Wire colors are LBE/R (+) LBE/GN (-)

Left (Belt Side) rear amp bypass plug

1. Unplug and remove OE amplifier from Left SaddleBag.
2. Plug in the Left Rear Bypass Plug into the connector removed from OE amp.
3. Connect the 900X Infinity wires to the two pin speaker connectors for the LEFT REAR WOOFER
4. If hard wiring is required the OE wire colors and polarity is below.
 - a. Wire colors are LBE/Y (+) LBE/PK (-)

For Tech Support questions on Infinity amplifiers and speakers please call:

800-553-3332

Monday - Friday: 9:00 AM - 11:00 PM (EST)

Saturday - Sunday: 9:00 AM - 5:00 PM (EST)

For all other tech support questions please call Metra's Tech support.

Having difficulties? We're here to help.



Contact our Tech Support line at:

386-257-1187



Or via email at:

techsupport@metra-autosound.com

Tech Support Hours (Eastern Standard Time)

Monday - Friday: 9:00 AM - 7:00 PM

Saturday: 10:00 AM - 5:00 PM

Sunday: 10:00 AM - 4:00 PM



KNOWLEDGE IS POWER

Enhance your installation and fabrication skills by enrolling in the most recognized and respected mobile electronics school in our industry. Log onto www.installerinstitute.edu or call 386-672-5771 for more information and take steps toward a better tomorrow.



**Metra recommends MECP
certified technicians**