



www.MetraOnline.com



MetraOnline.com may be used to assist with dash assembly instructions. Simply enter your **Year, Make, Model vehicle** into the vehicle fit guide and look for the **Dash Kit Installation Instructions**.

Chrysler Chime Interface 2013-2023

INTERFACE FEATURES

- Designed for non-amplified models
- Provides accessory power (12-volt 10-amp)
- Retains R.A.P. (Retained Accessory Power)
- Provides wires for multimedia radios (park brake, reverse, speed sense)
- Pre-wired AXSWC harness (AXSWC sold separately)
- Retains the factory backup camera (if displayed through the OE radio)
- Retains the 3.5mm AUX-IN jack
- Retains balance and fade
- Retains safety chimes
- Micro-B USB updatable

APPLICATIONS

Chrysler	Jeep
200 w/small screen 2015-2016	Cherokee Sport 2016
Dodge	RAM
Dart w/small screen 2013-2016	1500 (Classic) 2019-2023
Fiat	2500/3500
500 2015	w/small screen 2019-2023
500L 2014	1500/2500/3500
500X 2016	w/small screen 2013-2018

TABLE OF CONTENTS

Connections	
LD-AX-XSVI-CH3	2
Installation	3
Programming.....	3

TOOLS & INSTALLATION ACCESSORIES REQUIRED

- Cutting tool
- Tape
- Crimping tool
- Connectors (i.e. butt-connectors, bell caps, etc.)

INTERFACE COMPONENTS

- AXDI-CH5 interface
- LD-AX-XSVI-CH3 harness

Visit AxxessInterfaces.com

for more detailed information about the product and up-to-date vehicle specific applications

ATTENTION: With the key out of the ignition, disconnect the negative battery terminal before installing this product. Ensure that all installation connections, especially the air bag indicator lights, are plugged in before reconnecting the battery or cycling the ignition to test this product.

NOTE: Refer also to the instructions included with the aftermarket accessory before installing this device.

CONNECTIONS: LD-AX-XSVI-CH3 DIAGRAM

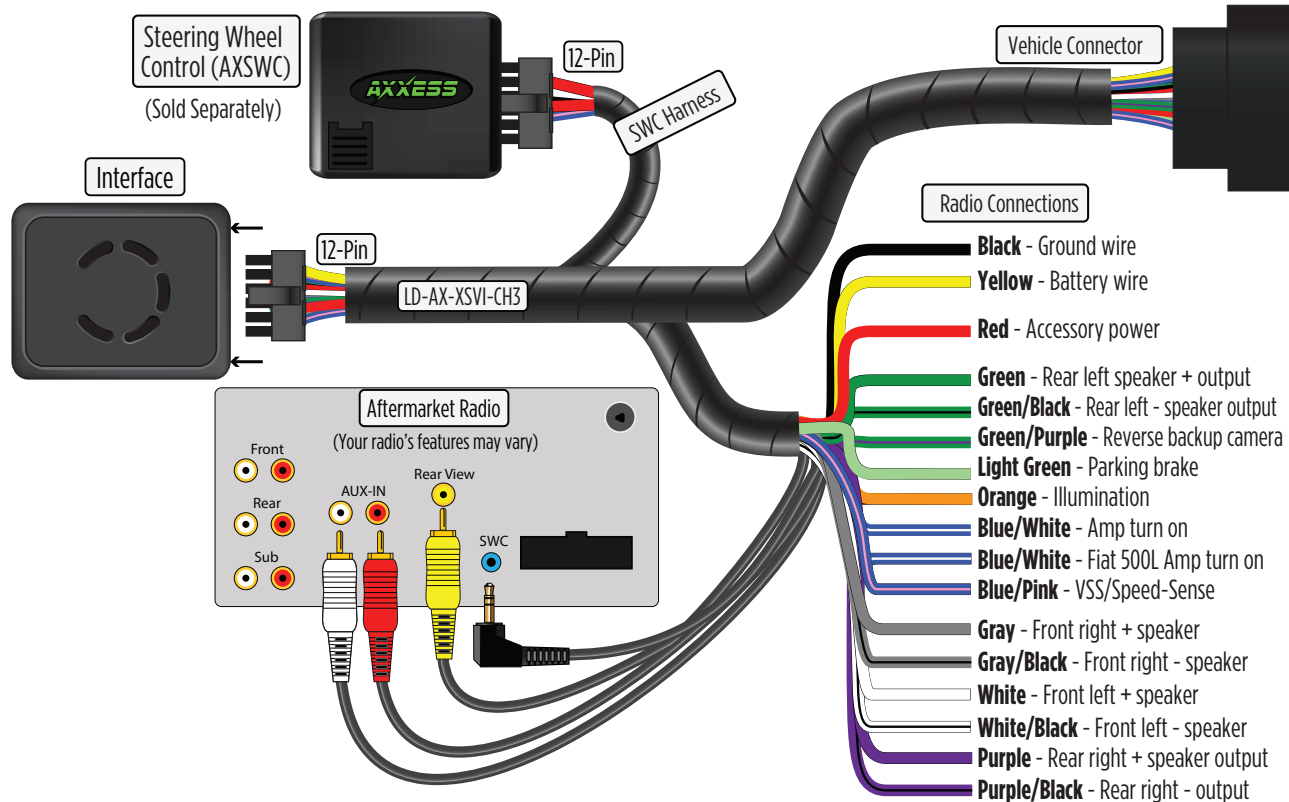

INSTALLATION

With the key in the off position:

- Connect the **LD-AX-XSVI-CH3 harness** into the interface, and then to the wiring harness in the vehicle.

PROGRAMMING

Attention! If the interface loses power for any reason, the following steps will need to be performed again. Also, if installing an AXSWC connect it after you initialize and test the interface/radio, with the key in the off position.

1. Turn the key (or push-to-start button) to the ignition position and wait until the radio comes on.
Note: If the radio does not come on within 60 seconds, turn the key to the off position, disconnect the interface, check all connections, reconnect the interface, and
2. Turn the key to the off position, and then to the accessory position. Test all functions of the installation for proper operation, before reassembling the dash.

Note: If using the AXSWC, connect it after you initialize the AXDI-CH5, with the key in the off position.



AXDI-CH5

INSTALLATION INSTRUCTIONS

Having difficulties? We're here to help.



Contact our Tech Support line at:

386-257-1187



Or via email at:

techsupport@metra-autosound.com

Tech Support Hours (Eastern Standard Time)

Monday - Friday: 9:00 AM - 7:00 PM

Saturday: 10:00 AM - 5:00 PM

Sunday: 10:00 AM - 4:00 PM



**Metra recommends MECP
certified technicians**