



Audi Data Interface 2002-2013

INTERFACE FEATURES

- Provides accessory power (12-volt 10-amp)
- Retains R.A.P. (Retained Accessory Power)
- Provides wires for multimedia radios (park brake, reverse, speed sense)
- Prewired AXSWC harness (AXSWC sold separately)
- Retains balance and fade
- Micro-B USB updatable

INTERFACE COMPONENTS

- AXDI-A12 interface
- LD-AX-XSVI-AU1 harness
- LD-AX-XSVI-AU2 harness

APPLICATIONS

LD-AX-XSVI-AU1 Harness:

A3 (1)	2006-2013
A4/RS 4/S4 (with NAV)	2005-2008
A4/RS 4/S4	2007-2008
A4/RS 4/S4	2006
TT	2008-2013

LD-AX-XSVI-AU2 Harness:

A3 (2)	2006-2007
A4/S4 (3)	2002-2006
A6	2004
Allroad	2004-2005
TT	2002-2006

- (1) With either Symphony Plus or NAV radio.
- (2) With Concert radio (without NAV)
- (3) With Symphony radio (without NAV)

TABLE OF CONTENTS

Connections.....	2-3
LD-AX-XSVI-AU1 Diagram.....	2
LD-AX-XSVI-AU2 Diagram.....	3
Installation.....	4
Programming.....	4

TOOLS & INSTALLATION ACCESSORIES REQUIRED

- Crimping tool and connectors, or solder gun, solder, and heat shrink
- Tape
- Wire cutter
- Zip-ties

Visit AxxessInterfaces.com for more detailed information about the product and up-to-date vehicle specific applications

ATTENTION: With the key out of the ignition, disconnect the negative battery terminal before installing this product. Ensure that all installation connections, especially the air bag indicator lights, are plugged in before reconnecting the battery or cycling the ignition to test this product. **NOTE:** Refer also to the instructions included with the aftermarket accessory before installing this device.

CONNECTIONS: LD-AX-XSVI-AU1 DIAGRAM

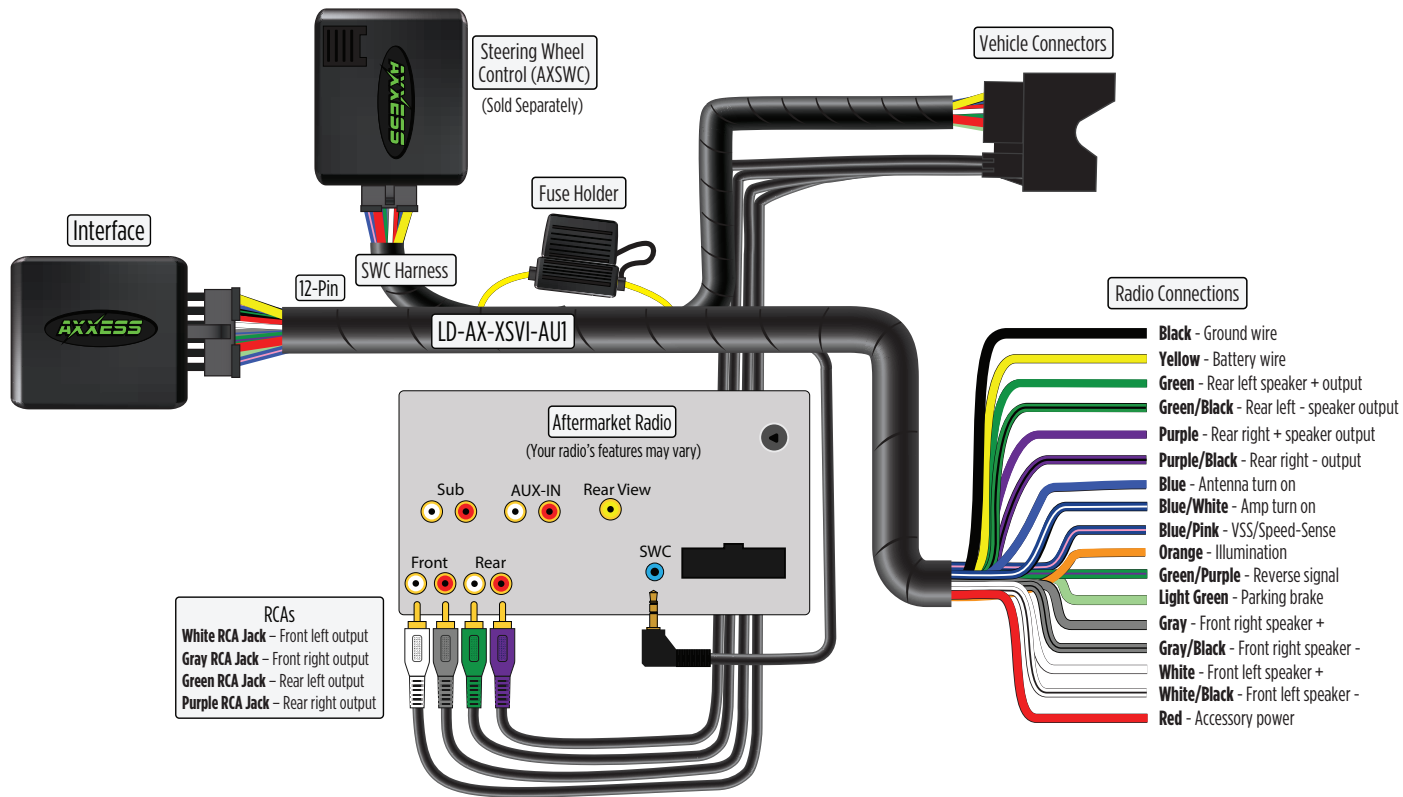

CONNECTIONS: LD-AX-XSVI-AU2 DIAGRAM

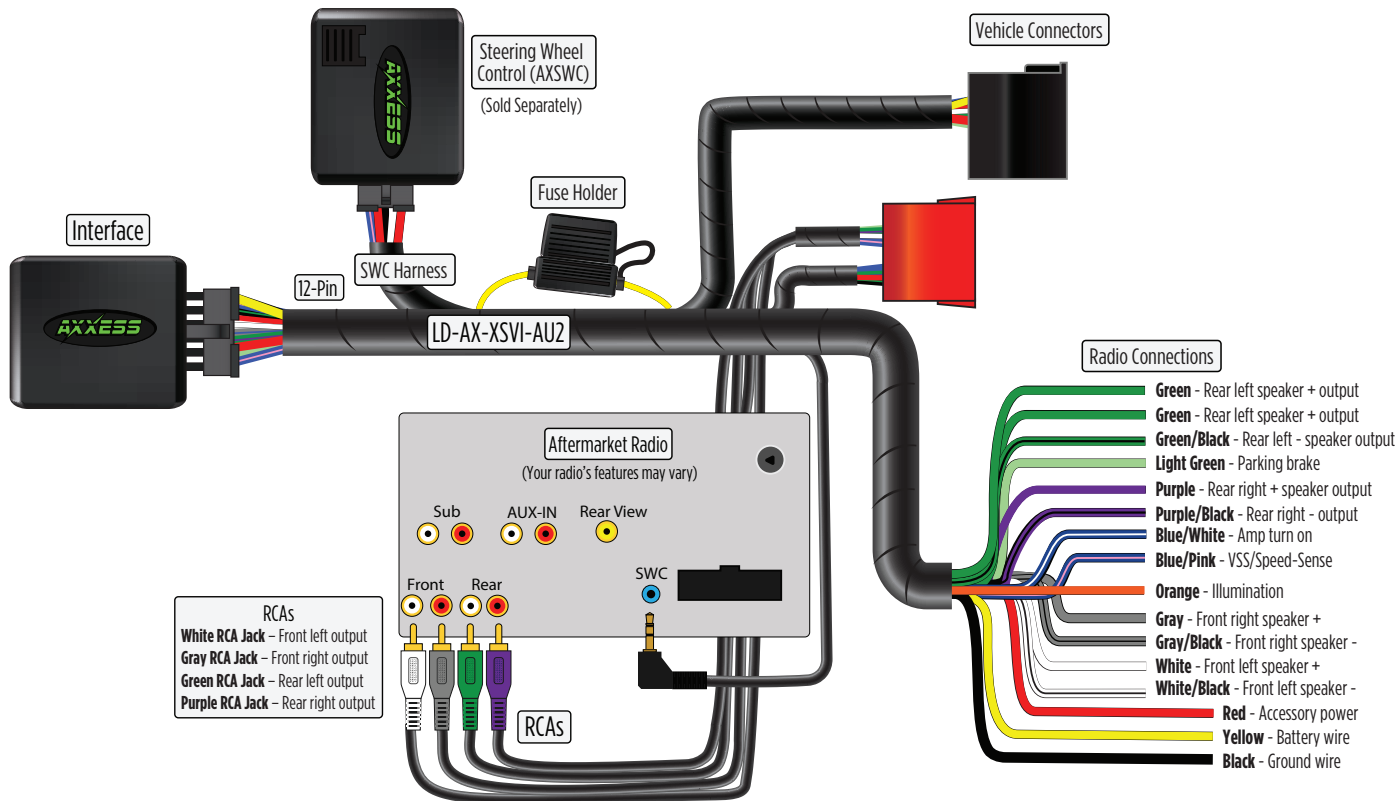



INSTALLATION

With the key in the off position:

- Connect the **LD-AX-XSVI-AU1** or **LD-AX-XSVI-AU2** harness into the interface, and then to the wiring harness in the vehicle.

PROGRAMMING

Attention! If the interface loses power for any reason, the following steps will need to be performed again. Also, if installing an AXSWC connect it after you initialize and test the interface/radio, with the key in the off position.

- Turn the key (or push-to-start button) to the ignition position and wait until the radio comes on.

Note: If the radio does not come on within 60 seconds, turn the key to the off position, disconnect the interface, check all connections, reconnect the interface, and then try again.

- Turn the key to the off position, and then to the accessory position. Test all functions of the installation for proper operation, before reassembling the dash.

Note: If using the AXSWC, connect it after you initialize the AXDI-A12, with the key in the off position.

Having difficulties? We're here to help.



Contact our Tech Support line at:

386-257-1187



Or via email at:

techsupport@metra-autosound.com

Tech Support Hours (Eastern Standard Time)

Monday - Friday: 9:00 AM - 7:00 PM

Saturday: 10:00 AM - 5:00 PM

Sunday: 10:00 AM - 4:00 PM



KNOWLEDGE IS POWER

Enhance your installation and fabrication skills by enrolling in the most recognized and respected mobile electronics school in our industry. Log onto www.installerinstitute.edu or call 386-672-5771 for more information and take steps toward a better tomorrow.



Metra recommends MECP certified technicians