



Installation instructions for part 99-6507

Patent # D503,401

## Chrysler/Dodge/Jeep (without NAV) 2005-2010 99-6507/CF-657CR/CHDK3

### KIT FEATURES

- DIN radio provision with pocket
- ISO DIN radio provision with pocket



### KIT COMPONENTS

- A) Radio housing • B) ISO snap-in brackets • C) Trim plates (upper and lower)

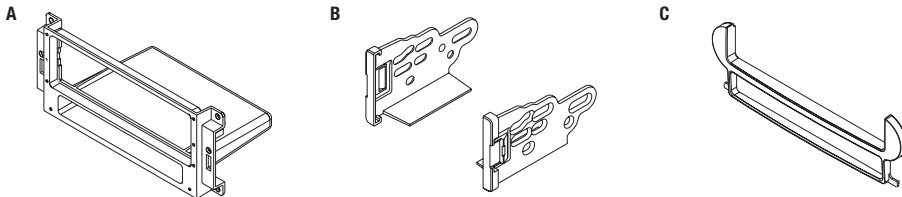

### APPLICATIONS

See application list inside cover

### WIRING & ANTENNA CONNECTIONS (sold separately)

#### Wiring Harness:

- CHT0-01 - For models with a factory amp
- XSVI-6502-NAV - For models without a factory amp

#### Antenna Adapter:

- 40-CR10

### TOOLS REQUIRED

- Panel removal tool • Phillips screwdriver
- Socket wrench

**CAUTION!** All accessories, switches, climate controls panels, and especially air bag indicator lights must be connected before cycling the ignition. Also, do not remove the factory radio with the key in the on position, or while the vehicle is running.

## Applications

<b>Chrysler</b>	Compass.....	2007-2008
300.....	Grand Cherokee.....	2005-2007
Aspen.....	Patriot.....	2007-2008
PT Cruiser.....		
<b>Dodge</b>	<b>Mitsubishi</b>	
Caliber.....	Raider.....	2006-2007
Charger.....		
Dakota.....		
Durango.....		
Magnum.....		
Ram 1500.....		
Ram 2500/3500.....		
Ram Chassis Cab.....		
<b>Jeep</b>		
Commander.....		

## Table of Contents

### Dash Disassembly

- Chrysler 300 2005-2007 .....	4
- Chrysler Aspen 2007 .....	3
- Chrysler PT Cruiser 2006-2010 .....	8
- Dodge Caliber 2007-2008 .....	7
- Dodge Charger 2006-2007.....	3
- Dodge Dakota 2005-2007.....	3
- Dodge Durango 2004-2007.....	3
- Dodge Magnum 2005-2007.....	3
- Dodge Ram: 1500 2006-2008, 2500/3500 2006-2009, Chassis Cab 2008-2010 (with full center console) .....	6
- Dodge Ram: 1500 2006-2008, 2500/3500 2006-2009, Chassis Cab 2008-2010 (with mini center console) .....	5
- Dodge Ram: 1500 2006-2008, 2500/3500 2006-2009, Chassis Cab 2008-2010 (without center console) .....	4
- Jeep Commander 2006-2007.....	8
- Jeep Compass 2007-2008.....	7
- Jeep Grand Cherokee 2005-2007.....	7
- Jeep Patriot 2007-2008.....	7
- Mitsubishi Raider 2006-2007.....	9

### Kit Assembly

- DIN radio provision with pocket .....	10
- ISO DIN radio provision with pocket .....	11

### Chrysler Aspen 2007, Dodge Dakota 2005-2007/Durango 2004-2007

1. Remove (2) 7mm screws from the inside of the pocket facing upward. (Figure A)
2. Unclip and remove the entire trim panel surrounding the radio and climate controls. (Figure B)
3. Remove (4) 7mm screws securing radio. Unplug and remove radio. (Figure C)

*Continue to kit assembly*

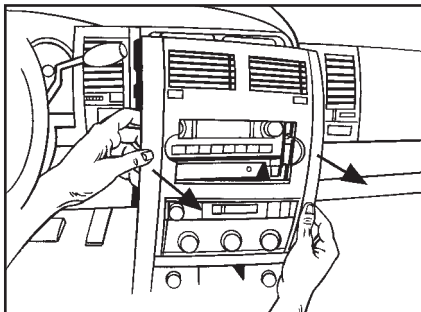

(Figure B)

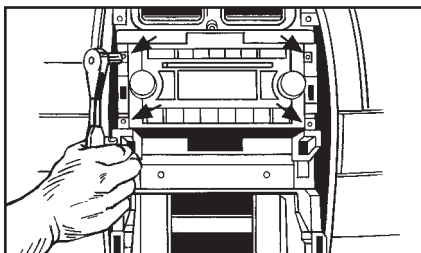

(Figure C)

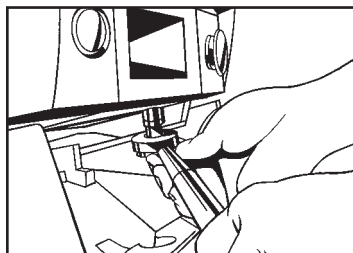

(Figure A)

### Dodge Charger 2006-2007 / Magnum 2005-2007

1. Unclip and remove entire panel surrounding radio and climate controls, including A/C vents. (Figure A)
2. Remove (4) 7mm screws securing radio. Unplug and remove radio. (Figure B)

*Continue to kit assembly*

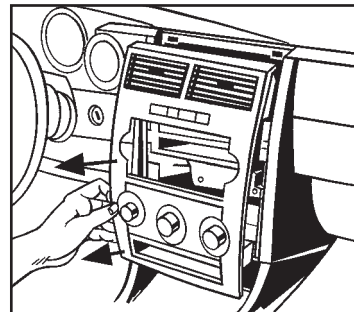

(Figure A)

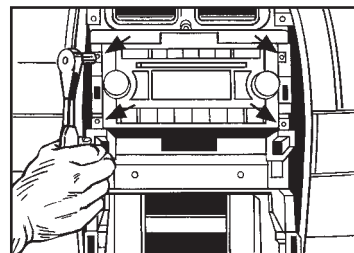

(Figure B)

### Chrysler 300 2005-2007

1. Unclip and remove entire panel surrounding radio and climate controls, including A/C vents and clock. (Figure A)
2. Remove (4) 7mm screws securing radio. Unplug and remove radio. (Figure B)

*Continue to kit assembly*

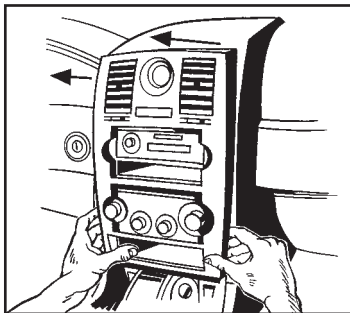

(Figure A)

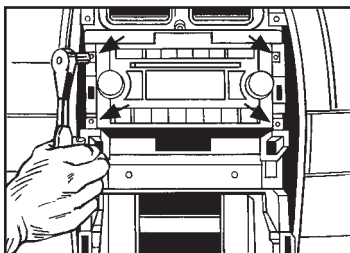

(Figure B)

### Dodge Ram 1500 2006-2008, 2500/3500 2006-2009, Chassis Cab 2008-2010 (without center console)

1. Open cup holder and remove (2) Phillips screws facing up on front edge of radio/climate control panel. (Figure A)
2. Unclip and remove entire panel surrounding radio and climate controls, including A/C vents. (Figure B)
3. Remove (4) 7mm screws securing radio. Unplug and remove radio.

*Continue to kit assembly*

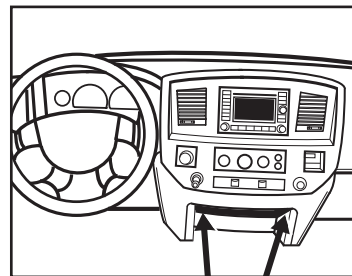

(Figure A)

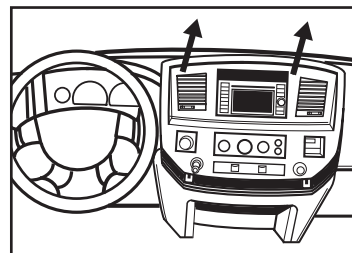

(Figure B)

### Dodge Ram 1500 2006-2008, 2500/3500 2006-2009, Chassis Cab 2008-2010 (with mini center console)

1. If vehicle has floor shifter, remove shifter knob. Then remove center console inserts, if present. (Figure A)
2. Remove screws securing the rear center console to the floor panel. Lift up on the rear center console to clear the gear shift lever, if present. (Figure B)
3. Remove screws securing the front center console to the floor panel. Unclip and remove the front center console. (Figure C)
4. Remove (2) Phillips head screws at bottom of dash. Unsnap and remove lower panel.
5. Remove (2) Phillips screws facing up on front edge of radio/climate control panel. (Figure D)
6. Unclip and remove entire panel surrounding radio and climate controls, including A/C vents. (Figure E)
7. Remove (4) 7mm screws securing radio to dash and remove radio.

*Continue to kit assembly*

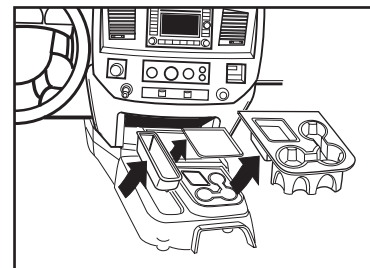

(Figure A)

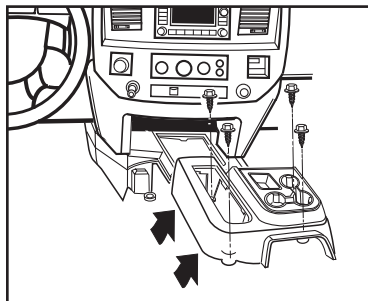

(Figure B)

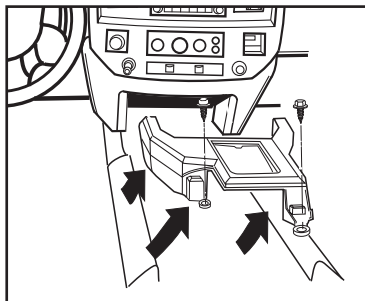

(Figure C)

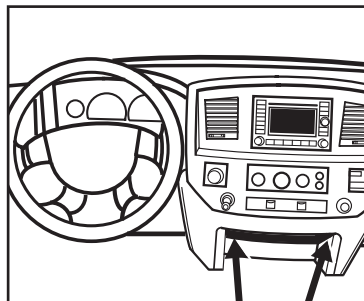

(Figure D)

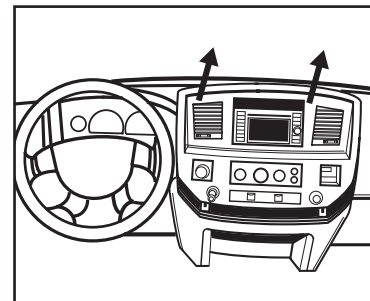

(Figure E)

**Dodge Ram 1500 2006-2008, 2500/3500 2006-2009,  
Chassis Cab 2008-2010** (with full center console)

1. If vehicle has floor shifter, remove shifter knob.
  2. Unsnap and remove console front top cover (closest to the dash). (Figure A)
  3. Remove (2) 8mm screws from under console cover (previously removed). Remove front section of console. (Figure B)
  4. Loosen (2) 8mm screws at bottom of dash. Unsnap lower panel.
  5. Remove (2) Phillips screws facing up on front edge of radio/climate control panel. (Figure C)
  6. Unclip and remove entire panel surrounding radio and climate controls, including A/C vents. (Figure D)
  7. Remove (4) 7mm screws securing radio to dash and remove radio.
- Continue to kit assembly*

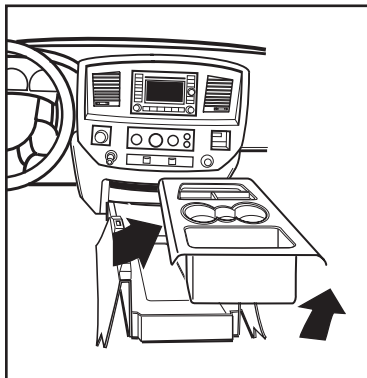

(Figure A)

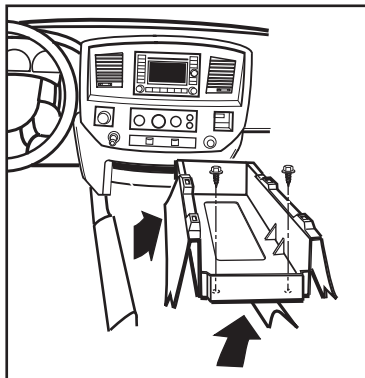

(Figure B)

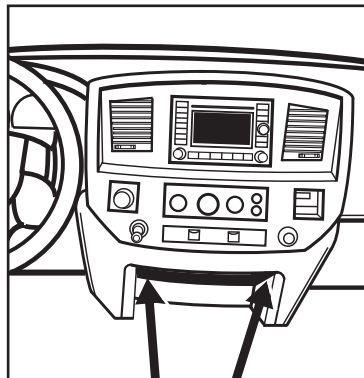

(Figure C)

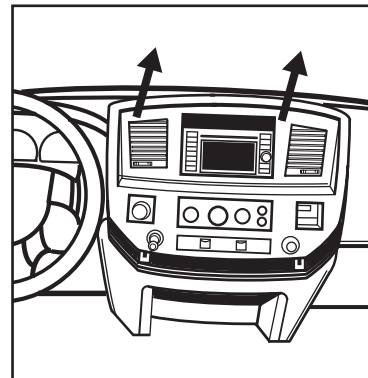

(Figure D)

## Dodge Caliber 2007-2008, Jeep Compass/Patriot 2007-2008

1. Unsnap and move shifter trim to the side. (Figure A)
2. (Compass and Patriot only) Unsnap and remove top center dash panel above A/C vents.
3. Unsnap center dash trim panel (do not remove until climate controls are removed). (Figure A)
4. Remove (4) Phillips screws holding climate control panel to backside of the center dash panel.
5. Remove (4) 7mm screws securing radio. Unplug and remove radio.

*Continue to kit assembly*

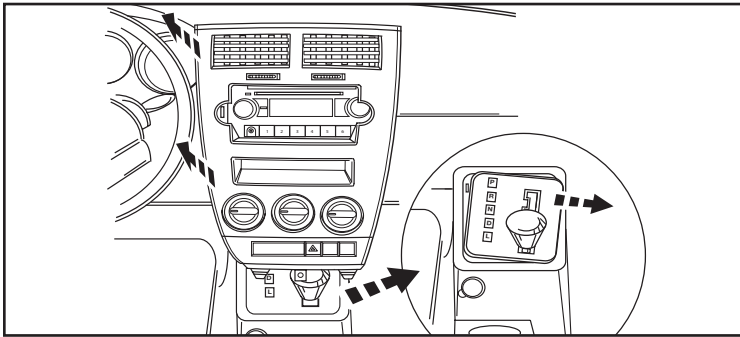

(Figure A)

## Jeep Grand Cherokee 2005-2007

1. Unsnap and remove panel from around radio including the vent on each side. (Figure A)
2. Remove (4) 7mm screws securing radio. Unplug and remove radio. (Figure B)

*Continue to kit assembly*

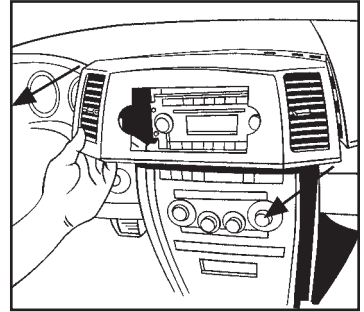

(Figure A)

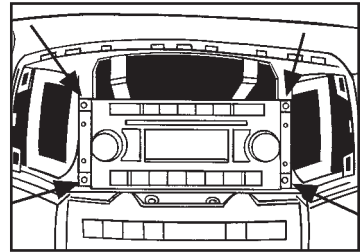

(Figure B)

### Jeep Commander 2006-2007

1. Remove the (16) screws securing the radio trim panel. (Figure A)
2. Unclip and remove the entire radio trim panel. (Figure B)
3. Remove (4) 7mm screws securing radio. Unplug and remove radio.

*Continue to kit assembly*

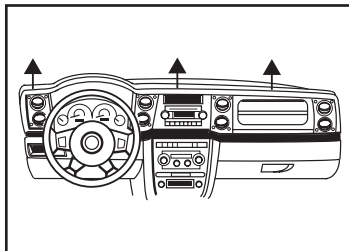

(Figure B)

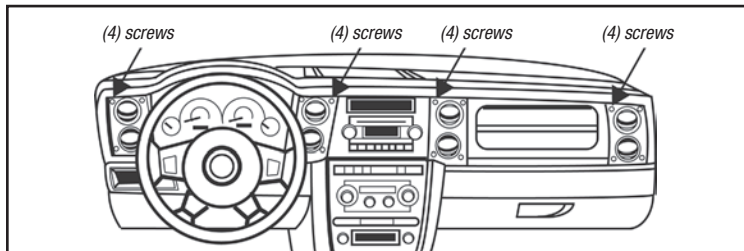

(Figure A)

### Chrysler PT Cruiser 2006-2010

1. Remove (2) screws from inside air vents on center dash panel. (Figure A)
2. Unsnap center dash panel (do not remove until climate controls are removed). (Figure A)
3. Remove (4) Phillips screws holding climate control panel to backside of the center dash panel.
4. Remove (4) 7mm screws securing radio. Unplug and remove radio.

*Continue to kit assembly*

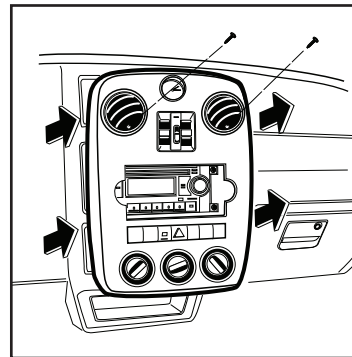

(Figure A)



**Mitsubishi Raider  
2006-2007**

**Notes**

1. Unsnap and remove center dash panel. (Figure A)
2. Remove (4) 7mm screws securing radio. Unplug and remove radio.

*Continue to kit assembly*

---

---

---

---

---

---

---

---

---

---

---

---

---

---

---

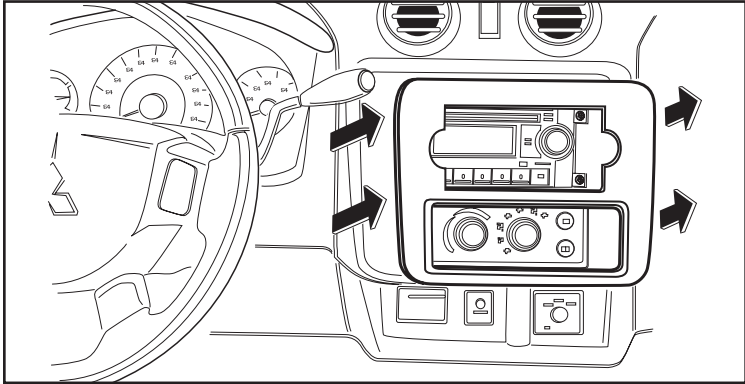

(Figure A)

## DIN radio provision with pocket

1. Remove the metal DIN sleeve and trim ring from the aftermarket radio.
2. Slide the sleeve into the *radio housing* and secure by bending the metal locking tabs down. (Figure A)
3. Slide the radio into the sleeve until it clicks in. (Figure B)
4. Using the alignment pins on the trim plates & the corresponding holes in the housing, attach the upper trim plate and the lower trim plate supplied with the kit. (Figure B)
5. Locate the factory wiring harness in the dash. Metra recommends using the proper mating adapter from Metra or AXCESS. Test the radio for proper operation.
6. Reassemble the dash in reverse order of disassembly.

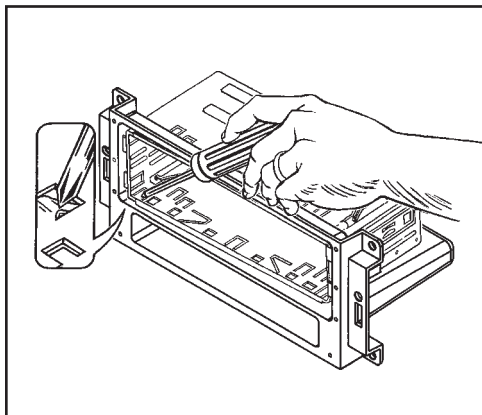

(Figure A)

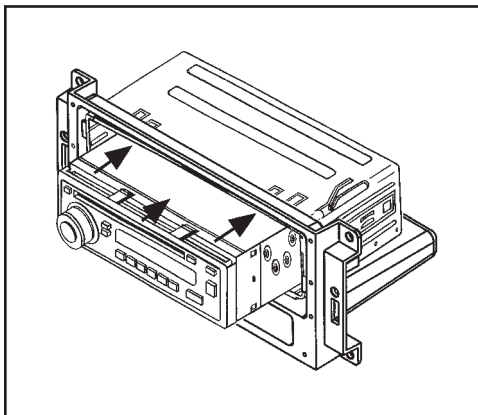

(Figure B)

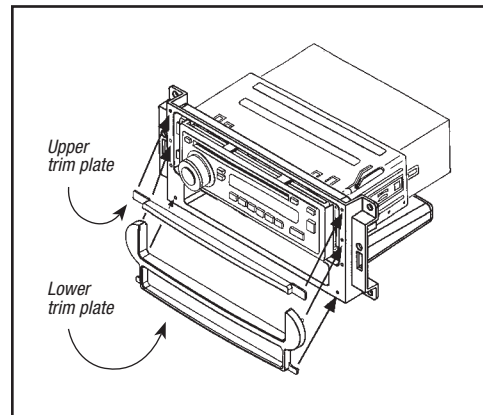

(Figure C)

## ISO DIN radio provision with pocket

1. Remove the metal DIN sleeve and trim ring from the aftermarket radio.
2. Mount the ISO Brackets to the radio using the screws supplied with the radio. (Figure A)
3. Slide the radio into the opening until it snaps into place. (Figure B)
4. Using the alignment pins on the trim plates & the corresponding holes in the housing, attach the upper trim plate and the lower trim plate supplied with the kit. (Figure B)
5. Locate the factory wiring harness in the dash. Metra recommends using the proper mating adapter from Metra or AXXESS. Test the radio for proper operation.
6. Reassemble the dash in reverse order of disassembly.

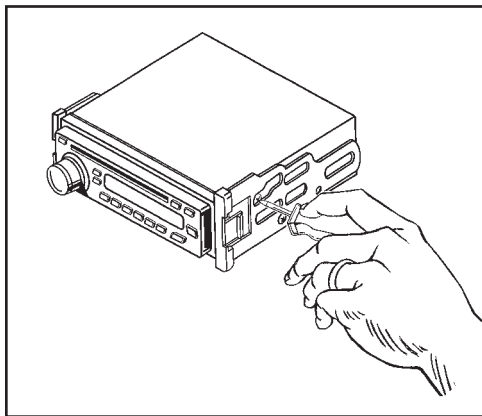

(Figure A)

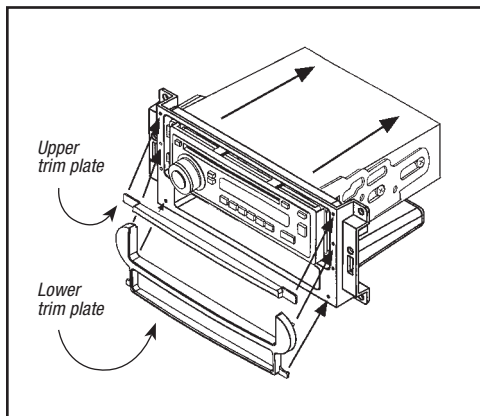

(Figure B)

**Notes**

---

---

---

---

---

---

---

---

---

---

---

---

---

---

---

---

---



99-6507

## Notes

---

---

---

---

---

---

---

---

---

---

---

---

---

---

---

---

**Notes**

---

---

---

---

---

---

---

---

---

---

---

---

---

---

---

---

---

---

---

---

---

---

---

---





Installation instructions for part 99-6507



## IMPORTANT

If you are having difficulties with the installation of this product, please call our Tech Support line at **1-800-253-TECH**. Before doing so, look over the instructions a second time, and make sure the installation was performed exactly as the instructions are stated. Please have the vehicle apart and ready to perform troubleshooting steps before calling.



### **KNOWLEDGE IS POWER**

Enhance your installation and fabrication skills by enrolling in the most recognized and respected mobile electronics school in our industry. Log onto [www.installerinstitute.com](http://www.installerinstitute.com) or call 800-354-6782 for more information and take steps toward a better tomorrow.



**Metra recommends MECP certified technicians**

REV 12/23/2020 INST-99-6507



## Chrysler/Dodge/Jeep (sin NAV) 2005-2010 99-6507/CF-657CR/CHDK3

### CARACTERÍSTICAS DEL KIT

- Provisión de radio DIN con bolsillo
- Provisión de radio ISO DIN con bolsillo

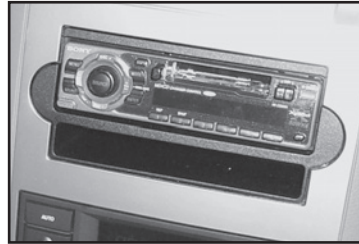

### COMPONENTES DEL KIT

- A) Carcasa del radio • B) Soportes ISO a presión • C) Placas de moldura (superior e inferior)

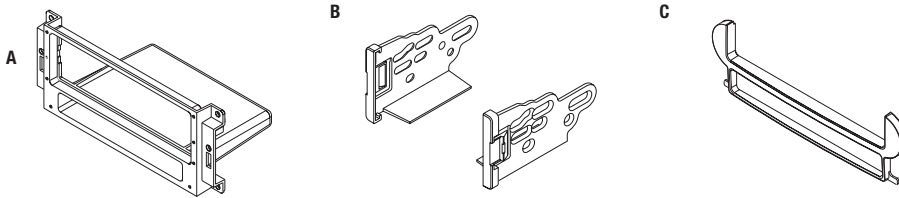

### APLICACIONES

Ver interior de la portada

### CABLEADO Y CONEXIONES DE ANTENA

Arnés de cableado: (se venden por separado)

- CHTO-01 - Para los modelos con un amplificador de fábrica
- XSVI-6502-NAV - Para los modelos sin un amplificador de fábrica

Adaptador de antena:

- 40-CR10

### HERRAMIENTAS REQUERIDAS

- Herramienta de remoción de panel
- Destornillador Phillips • Llave de tubo

**¡PRECAUCIÓN!** Todos los accesorios, interruptores, paneles de controles de clima y especialmente las luces del indicador de las bolsas de aire deben estar conectados antes de ciclar la ignición. Además, no quite el radio de fábrica con la llave en la posición o de encendido ni con el vehículo funcionando.

## Aplicaciones

### Chrysler

300.....	2005-2007
Aspen.....	2007
PT Cruiser.....	2006-2010

### Dodge

Caliber.....	2007-2008
Charger.....	2006-2007
Dakota.....	2005-2007
Durango.....	2004-2007
Magnum.....	2005-2007
Ram 1500.....	2006-2008
Ram 2500/3500.....	2006-2009
Ram Chassis Cab.....	2008-2010

### Jeep

Commander.....	2006-2007
Compass.....	2007-2008
Grand Cherokee.....	2005-2007
Patriot.....	2007-2008

### Mitsubishi

Raider.....	2006-2007
-------------	-----------

## Índice

### Desmontaje del tablero

- Chrysler 300 2005-2007 .....	4
- Chrysler Aspen 2007 .....	3
- Chrysler PT Cruiser 2006-2010 .....	8
- Dodge Caliber 2007-2008 .....	7
- Dodge Charger 2006-2007 .....	3
- Dodge Dakota 2005-2007 .....	3
- Dodge Durango 2004-2007 .....	3
- Dodge Magnum 2005-2007 .....	3
- Dodge Ram: 1500 2006-2008, 2500/3500 2006-2009, Chassis Cab 2008-2010 (con consola central completa).....	6
- Dodge Ram: 1500 2006-2008, 2500/3500 2006-2009, Chassis Cab 2008-2010 (con consola central pequeña) .....	5
- Dodge Ram: 1500 2006-2008, 2500/3500 2006-2009, Chassis Cab 2008-2010 (sin consola central).....	4
- Jeep Commander 2006-2007 .....	8
- Jeep Compass 2007-2008 .....	7
- Jeep Grand Cherokee 2005-2007 .....	7
- Jeep Patriot 2007-2008.....	7
- Mitsubishi Raider 2006-2007 .....	9

### Ensamble del kit

- Provisión de radio DIN con bolsillo .....	10
- Provisión de radio ISO DIN con bolsillo.....	11

**Chrysler Aspen 2007, Dodge  
Dakota 2005-2007/Durango 2004-2007**

1. Retire los (2) tornillos de 7 mm de la parte interior del bolsillo hacia arriba. (Figura A)
2. Suelte y retire todo el panel de la moldura que rodea el radio y los controles de clima. (Figura B)
3. Retire los (4) tornillos de 7 mm que sostienen el radio. Desconecte y retire el radio. (Figura C)

*Continuará al ensamble del kit*

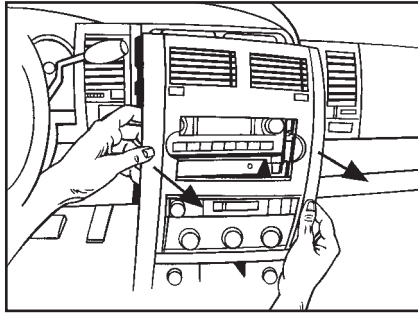

(Figura B)

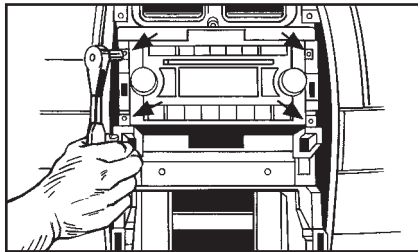

(Figura C)

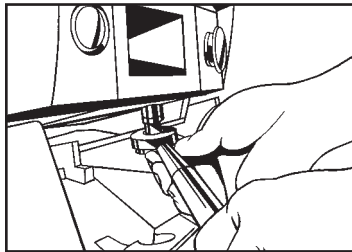

(Figura A)

**Dodge Charger 2006-2007 /  
Magnum 2005-2007**

1. Suelte y retire todo el panel que rodea el radio y los controles del clima, incluyendo las rejillas del aire acondicionado. (Figura A)
2. Retire los (4) tornillos de 7 mm que sostienen el radio. Desconecte y retire el radio. (Figura B)

*Continuará al ensamble del kit*

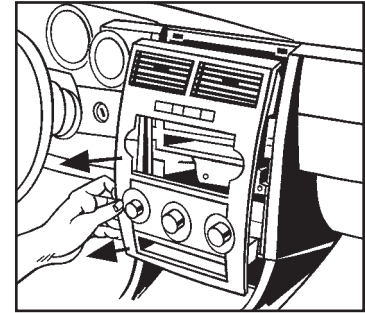

(Figura A)

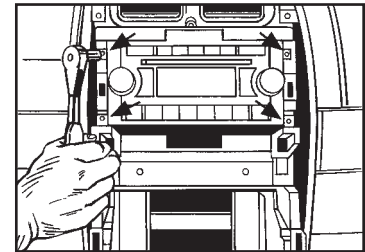

(Figura B)

**Chrysler 300  
2005-2007**

1. Suelte y retire todo el panel que rodea el radio y los controles del clima, incluyendo las rejillas del aire acondicionado y el reloj. (Figura A)
2. Retire los (4) tornillos de 7 mm que sostienen el radio. Desconecte y retire el radio. (Figura B)

*Continuará al ensamble del kit*

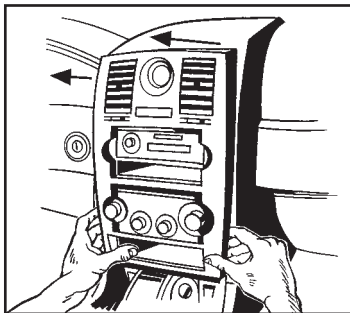

(Figura A)

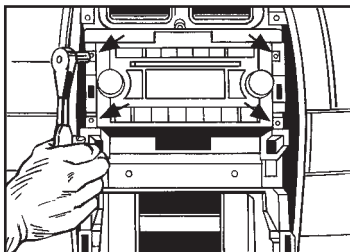

(Figura B)

**Dodge Ram 1500 2006-2008,  
2500/3500 2006-2009,  
Chassis Cab 2008-2010 (sin consola central)**

1. Abra el portavasos y retire los (2) tornillos Phillips que están hacia arriba en el borde frontal del panel del radio/control de clima. (Figura A)
2. Suelte y retire todo el panel que rodea el radio y los controles del clima, incluyendo las rejillas del aire acondicionado. (Figura B)
3. Retire los (4) tornillos de 7 mm que sostienen el radio. Desconecte y retire el radio.

*Continuará al ensamble del kit*

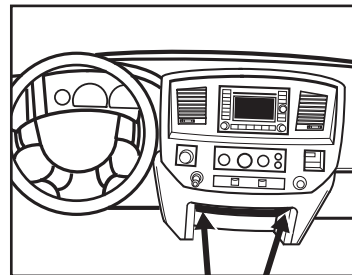

(Figura A)

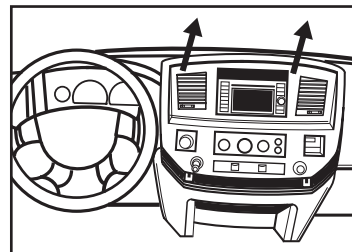

(Figura B)

### Dodge Ram 1500 2006-2008, 2500/3500 2006-2009, Chassis Cab 2008-2010 (consola central *pequeña*)

1. Si el vehículo tiene palanca de velocidades al piso, quite la perilla de la palanca. Retire los insertos de la consola central, si los hay. (Figura A)
2. Retire los tornillos que sujetan la consola central trasera al panel del piso. Levante la consola central trasera para despejar el área de la palanca de velocidades, si la hay. (Figura B)
3. Retire los tornillos que sujetan la consola central delantera al panel del piso. Suelte y retire la consola central delantera. (Figura C)
4. Retire los (2) tornillos de cabeza Phillips de la parte inferior del tablero. Suelte y retire el panel inferior.
5. Retire los (2) tornillos Phillips que están hacia arriba en el borde frontal

- del panel del radio/control de clima. (Figura D)
6. Suelte y retire todo el panel que rodea el radio y los controles del clima, incluyendo las rejillas del aire acondicionado. (Figura E)
7. Retire los (4) tornillos de 7 mm que sujetan el radio al tablero y retire el radio.

*Continuará al ensamble del kit*

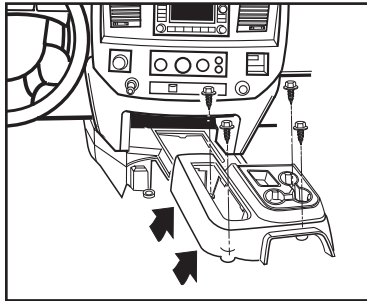

(Figura B)

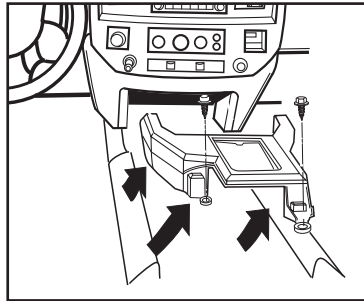

(Figura C)

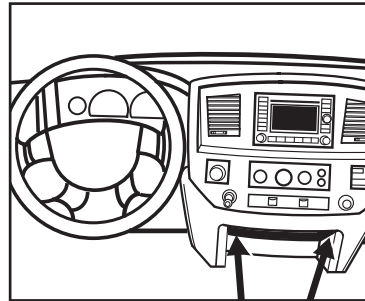

(Figura D)

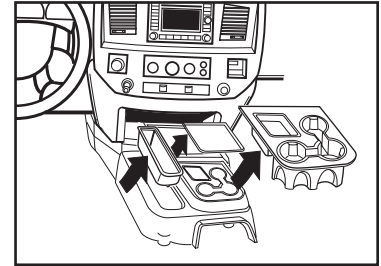

(Figura A)

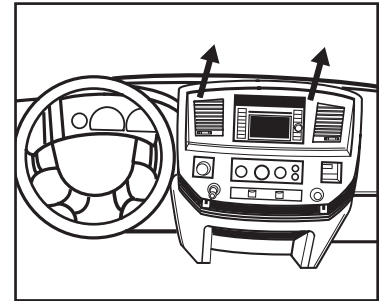

(Figura E)

## **Dodge Ram 1500 2006-2008, 2500/3500 2006-2009, Chassis Cab 2008-2010** *(con consola central completa)*

1. Si el vehículo tiene palanca de velocidades al piso, quite la perilla de la palanca.
2. Suelte y retire la cubierta superior del frente de la consola (más cercana al tablero). (Figura A)
3. Retire los (2) tornillos de 8 mm de debajo de la cubierta de la consola (anteriormente retirada).
4. Afloje los (2) tornillos de 8 mm de la parte inferior del tablero. Suelte el panel inferior.
5. Retire los (2) tornillos Phillips que están hacia arriba en el borde frontal del panel del radio/control de clima. (Figura C)
6. Suelte y retire todo el panel que rodea el radio y los controles del clima, incluyendo las rejillas del aire acondicionado. (Figura D)
7. Retire los (4) tornillos de 7 mm que sujetan el radio al tablero y retire el radio.

*Continuará al ensamble del kit*

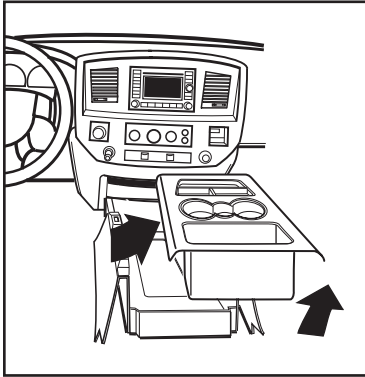

(Figura A)

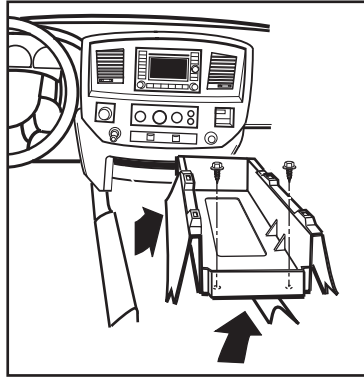

(Figura B)

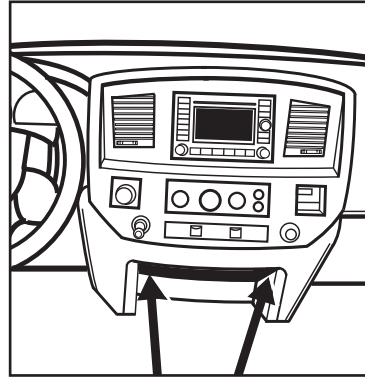

(Figura C)

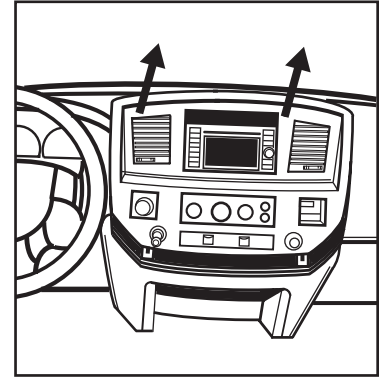

(Figura D)

### Dodge Caliber 2007-2008, Jeep Compass/Patriot 2007-2008

1. Suelte y mueva la moldura de la palanca de velocidades a un lado. (Figura A)
2. Suelte y retire el panel superior del tablero central sobre las rejillas del aire acondicionado (solo Compass y Patriot).
3. Suelte el panel de la moldura del tablero central (no lo retire hasta que se hayan retirado los controles de clima). (Figura A)
4. Retire los (4) tornillos Phillips que sostienen el panel de control de clima a la parte posterior del panel del tablero central.
5. Retire los (4) tornillos de 7 mm que sostienen el radio. Desconecte y retire el radio.

*Continuará al ensamble del kit*

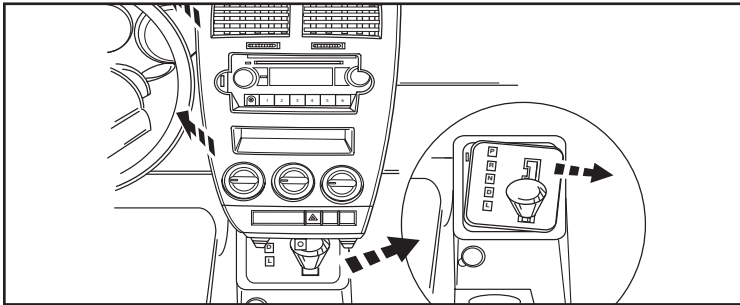

(Figura A)

### Jeep Grand Cherokee 2005-2007

1. Suelte y retire el panel de alrededor del radio, incluyendo la rejilla a cada lado. (Figura A)
2. Retire los (4) tornillos de 7 mm que sostienen el radio. Desconecte y retire el radio. (Figura B)

*Continuará al ensamble del kit*

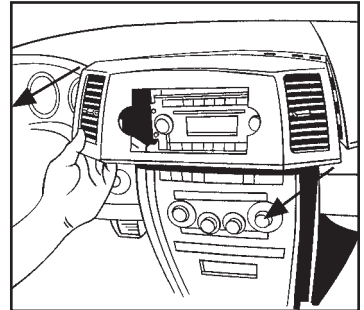

(Figura A)

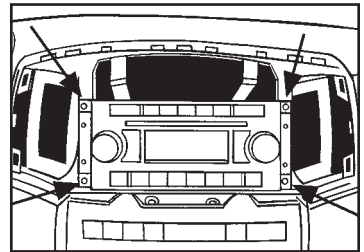

(Figura B)

**Jeep Commander  
2006-2007**

1. Retire los (16) tornillos que aseguran el panel de la moldura del radio. (Figura A)
2. Suelte y retire todo el panel de la moldura del radio. (Figura B)
3. Retire los (4) tornillos de 7 mm que sostienen el radio. Desconecte y retire el radio.

*Continuará al ensamble del kit*

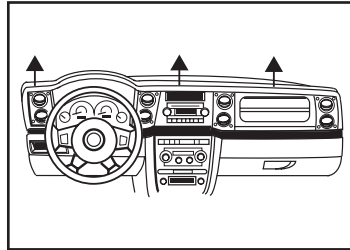

(Figura B)

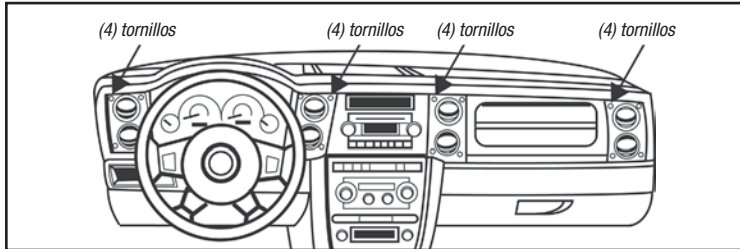

(Figura A)

**Chrysler PT Cruiser  
2006-2010**

1. Retire los (2) tornillos de las rejillas interiores en el panel del tablero central. (Figura A)
2. Suelte el panel del tablero central (no lo retire hasta que se hayan retirado los controles de clima). (Figura A)
3. Retire los (4) tornillos Phillips que sostienen el panel de control de clima a la parte posterior del panel del tablero central.
4. Retire los (4) tornillos de 7 mm que sostienen el radio. Desconecte y retire el radio.

*Continuará al ensamble del kit*

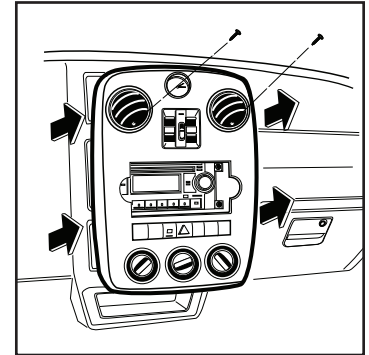

(Figura A)



**Mitsubishi Raider  
2006-2007****Notas**

---

---

---

---

---

---

---

---

---

---

1. Suelte y retire el panel del tablero central. (Figura A)
2. Retire los (4) tornillos de 7 mm que sostienen el radio. Desconecte y retire el radio.

*Continuará al ensamble del kit*

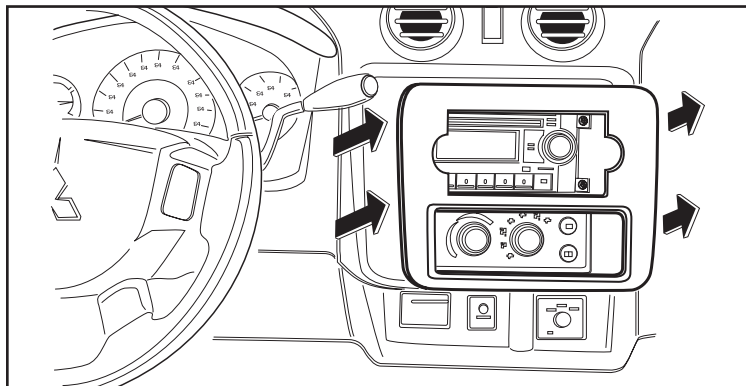

(Figura A)

## Provisión de radio DIN con bolsillo

1. Quite la manga de metal DIN y el anillo de moldura del radio de mercado secundario.
2. Deslice la manga en la *carcasa del radio* y sujétela doblando hacia abajo las pestañas de metal. (Figura A)
3. Deslice el radio de nuevo en la manga hasta que haga clic. (Figura B)
4. Usando las espigas de alineación de las placas de la moldura y los orificios correspondientes de la carcasa, una las placas de moldura superior e inferior suministradas con el kit. (Figura B)
5. Ubique el arnés del cableado de fábrica en el tablero. Metra recomienda usar el adaptador de acoplamiento adecuado de Metra o AXXESS. Pruebe la radio para verificar que funcione correctamente.
6. Vuelva a montar el tablero en forma inversa al desmontaje.

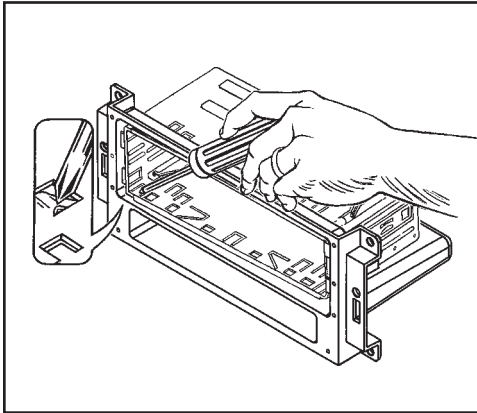

(Figura A)

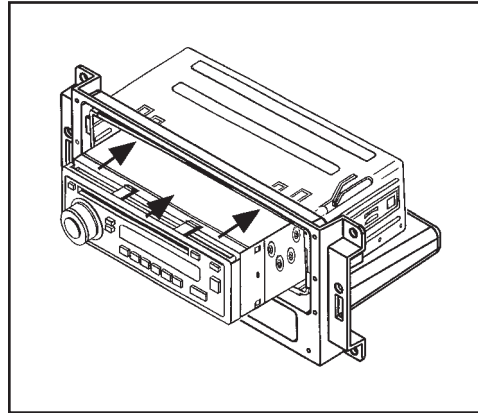

(Figura B)

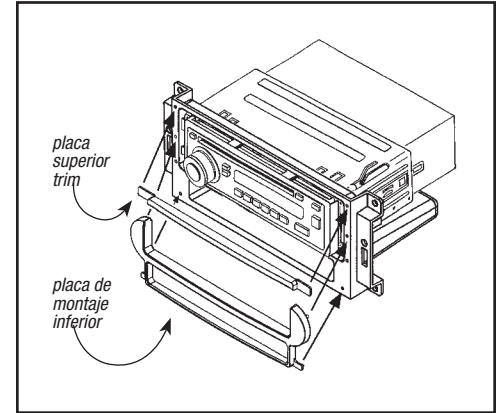

(Figura C)

## Provisión de radio ISO DIN con bolsillo

1. Quite la manga de metal DIN y el anillo de moldura del radio de mercado secundario.
2. Seguro los soportes ISO en el radio con los tornillos incluidos con el radio. (Figura A)
3. Deslice el radio en la apertura hasta que entre a presión. (Figura B)
4. Usando las espigas de alineación de las placas de la moldura y los orificios correspondientes de la carcasa, una las placas de moldura superior e inferior suministradas con el kit. (Figura B)
5. Ubique el arnés del cableado de fábrica en el tablero. Metra recomienda usar el adaptador de acoplamiento adecuado de Metra o AXCESS. Pruebe la radio para verificar que funcione correctamente.
6. Vuelva a montar el tablero en forma inversa al desmontaje.

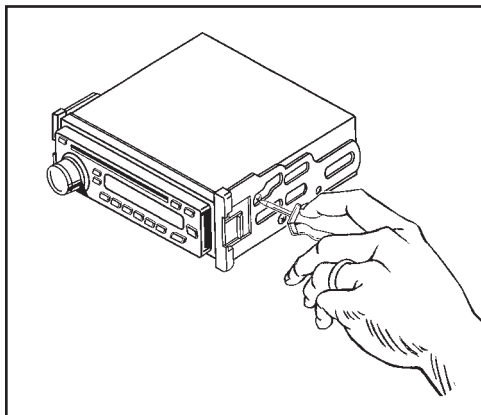

(Figura A)

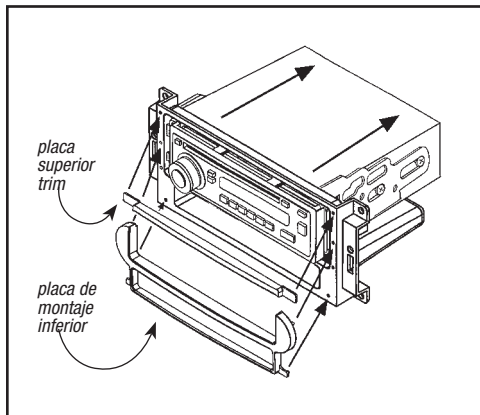

(Figura B)



**99-6507**

**Notas**

---

---

---

---

---

---

---

---

---

---

---

---

---

---

---

---

---

---

---

---



**99-6507**

### **Notas**

---

---

---

---

---

---

---

---

---

---

---

---

---

---

---

---

---

---

---

---

---

---

---

---

**Notas**

---

---

---

---

---

---

---

---

---

---

---

---

---

---

---

---

---

---

---

---

**Notas**

---

---

---

---

---

---

---

---

---

---

---

---

---

---

---

---

---

---

---

---

---

---

---

---

---

---



Instrucciones de instalación para la pieza 99-6507



## IMPORTANTE

Si tiene dificultades con la instalación de este producto, llame a nuestra línea de soporte técnico al **1-800-253-TECH**. Antes de hacerlo, revise las instrucciones por segunda vez y asegúrese de que la instalación se haya realizado exactamente como se indica en las instrucciones. Por favor tenga el vehículo desarmado y listo para ejecutar los pasos de resolución de problemas antes de llamar.



### EL CONOCIMIENTO ES PODER

Mejore sus habilidades de instalación y fabricación inscribiéndose en la escuela de dispositivos electrónicos móviles más reconocida y respetada de nuestra industria. Regístrese en [www.installerinstitute.com](http://www.installerinstitute.com) o llame al 800-354-6782 para obtener más información y avance hacia un futuro mejor.



**Metra recomienda técnicos con certificación del Programa de Certificación en Electrónica Móvil (Mobile Electronics Certification Program, MECP).**

REV 12/23/2020 INST-99-6507