



Cadillac SRX 2010-2012

Visit MetraOnline.com for more detailed information about the product and up-to-date vehicle specific applications

KIT FEATURES

- Designed for most shallow mount aftermarket radios and Pioneer modular radios DMH-C2550NEX and DMH-C2500NEX
- Note** – see manufacturer for current models.
- Retains factory control panel and display of climate functions and vehicle customization menus on the 107-GM5B OLED screen.
- Retains audio control on steering wheel and radio control buttons on the factory control panel

KIT COMPONENTS

- A) Center dash panel • B) Top trim panel • C) Radio brackets • D) Pioneer display brackets • E) Pioneer chassis brackets
- F) Three panel clips (top panel) • G) Interface and wiring (not shown)

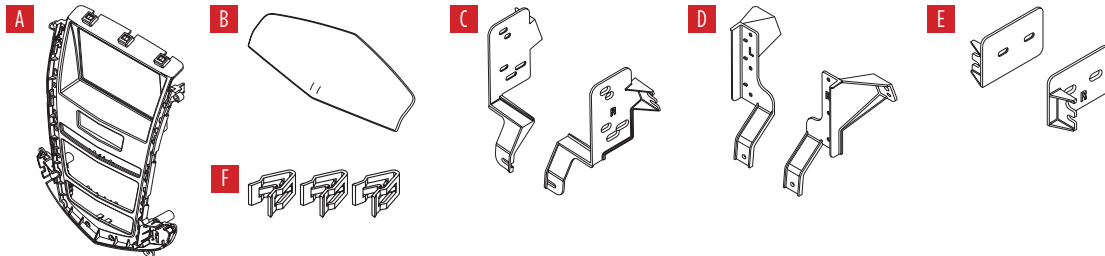

TABLE OF CONTENTS

Dash Disassembly	2-3
Kit Preparation	4-6
Kit Assembly	
– Shallow DDIN radio provision	7
– Pioneer modular DDIN radio provision	8

WIRING & ANTENNA CONNECTIONS

- Wire harness: Axxess interface included
- Antenna adapter: Included
- Steering wheel control interface: Included
- RGB Extension Cable: Pioneer part # CD-RGB150E (not sold by Metra)

TOOLS REQUIRED

- Panel removal tool • Phillips screwdriver
- 9/32" Socket wrench • T-15 Torx screwdriver

Attention! Let the vehicle sit with the key out of the ignition for a few minutes before removing the factory radio. When testing the aftermarket equipment, ensure that all factory equipment is connected before cycling the key to ignition.

DASH DISASSEMBLY

1. Unclip and remove the trim panels from the sides of the center console. (Figure A)
2. Remove (2) 9/32" screws securing the padded trim to the center console, then unclip and remove. Do the same for the opposite side. (Figure B)
3. Unsnap and remove the u-shaped trim around the lower dash pocket. (Figure C)

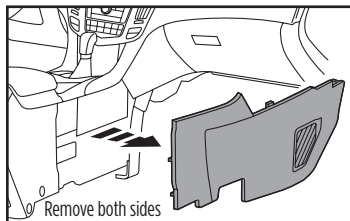

(Figure A)

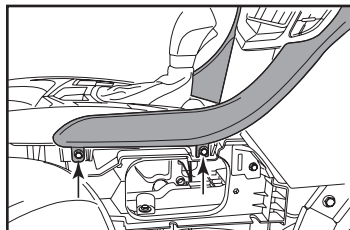

(Figure B)

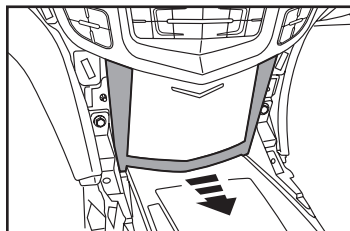

(Figure C)

4. Remove (2) 9/32" screws securing the lower portion of the control panel. (Figure D)
5. Pull the pocket from the top to allow the upper control panel to pass. (Figure E)

Continued on the next page

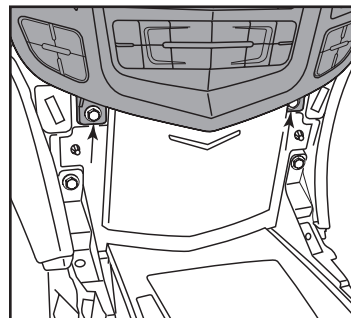

(Figure D)

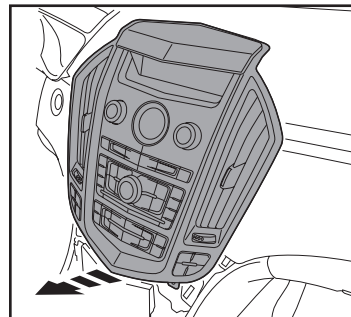

(Figure E)

DASH DISASSEMBLY (CONT.)

NAV Models

7. For NAV equipped models, motorize the screen up, unclip the left & right legs securing the trim over the top of the motorized display screen, then lift up to remove the trim. (Figure F)

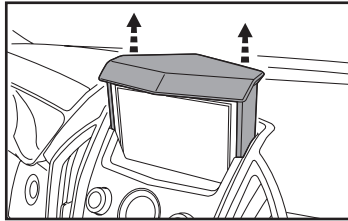

(Figure F)

- 7a. Unplug the control panel and lift up enough to access the (2) 9/32" screws and 10mm nut. Plug the control panel back in and power the screen down to remove the control panel. (Figure G)

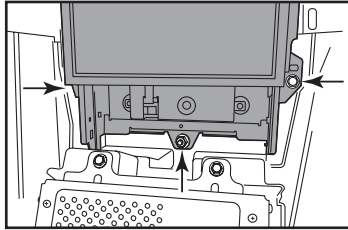

(Figure G)

Note: if the airbag light is unplugged during this process be sure not to cycle the ignition

- 7b. Unclip, unplug, and remove the control panel. (Figure H)

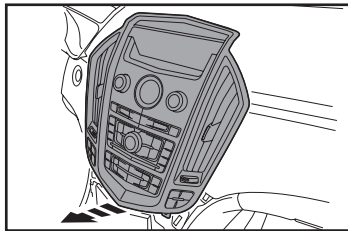

(Figure H)

Both NAV and non-NAV

8. Remove (4) 9/32" screws securing the radio chassis. Slide the chassis out, then unplug and remove. (Figure I)

Continue to Kit Preparation

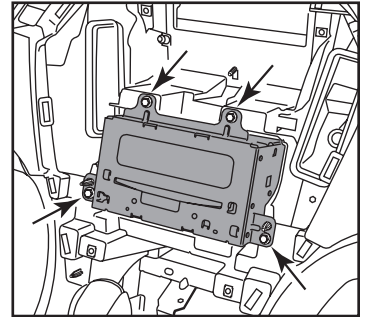

(Figure I)

KIT PREPARATION

From the factory control panel:

NON-NAV

1. Unsnap the top trim panel from the control panel. (above the screen) (Figure A)
2. Remove (4) screws and the factory screen. (Figure B)
3. Remove (6) screws to remove the factory screen bezel. (Figure C)

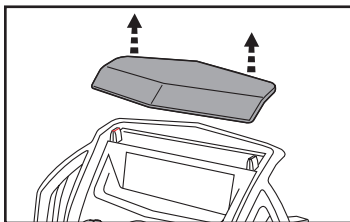

(Figure A)

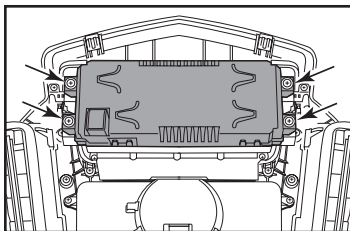

(Figure B)

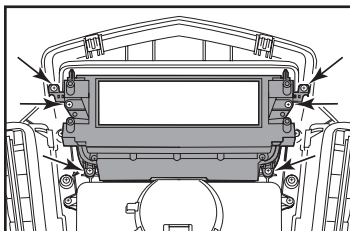

(Figure C)

From the factory control panel:

NAV models

1. Remove (4) screws to remove the factory screen bezel. (Figure A)

Continued on the next page

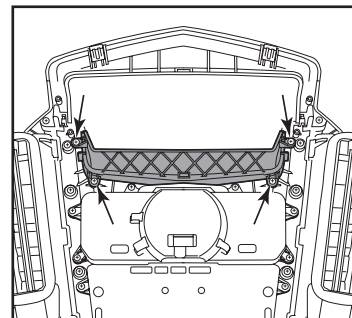

(Figure A)

KIT PREPARATION (CONT.)

From the factory control panel:

Both NAV and NON-NAV

4. Remove (6) Phillips screws securing the clock panel. Unplug and remove. (Figure D)
5. Remove (10) Phillips screws securing the control button panel, then unplug and remove the panel. (Figure E)
6. Remove (16) Phillips screws securing the inner housing, unplug the lower climate controls, then remove the housing from the outer silver trim. (Figure F)

Continued on the next page

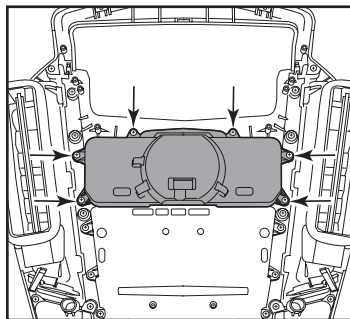

(Figure D)

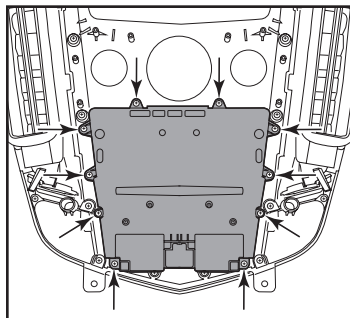

(Figure E)

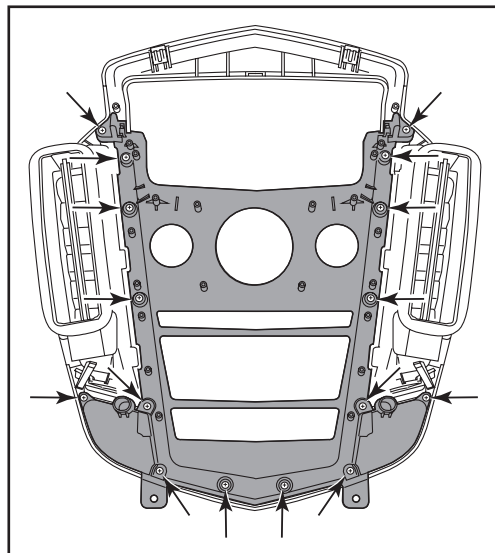

(Figure F)

KIT PREPARATION (CONT.)

Dash Panel Assembly

7. Secure the 107-GM5B dash panel using (16) factory screws. (Figure G)
8. Cut off the top (2) mounting legs from the main factory climate buttons. (Figure H)
9. Secure the main factory climate buttons using (8) factory screws. (Figure I)
10. Connect the lower climate controls. Caution, the connector can be forced in wrong. Make sure the keyways line up.

Continue to Kit Assembly

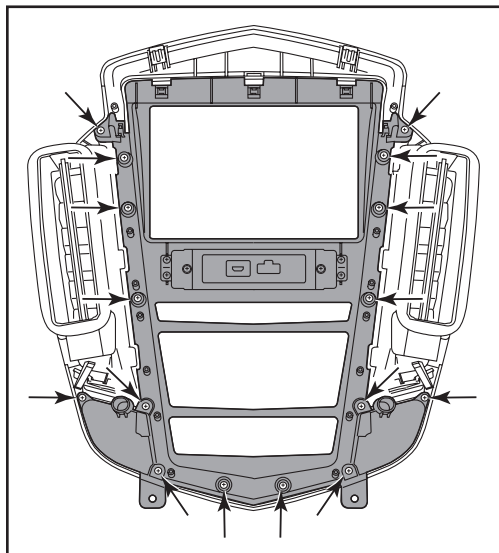

(Figure G)

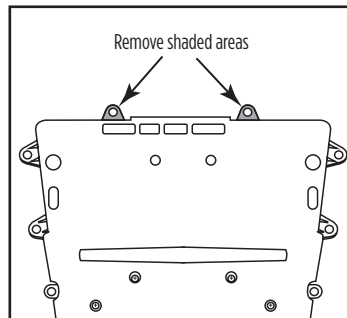

(Figure H)

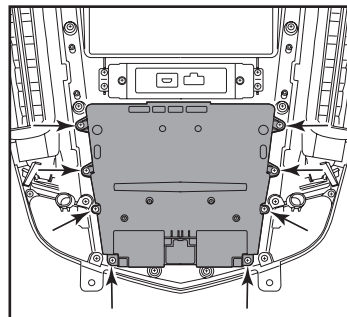

(Figure I)

KIT ASSEMBLY

ISO DDIN radio provision

1. Secure the **radio brackets** to the radio using (4) screws supplied with the radio. (Figure A)
2. Using the factory screws, secure the radio/bracket assembly to the dash where the factory display was located. (Figure B)

Continue to Axxess Interface Installation

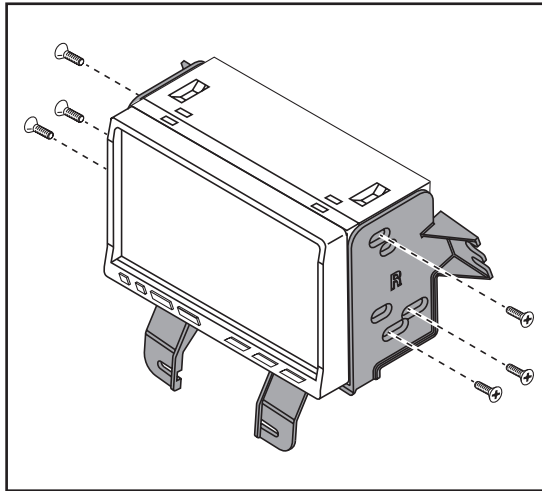

(Figure A)

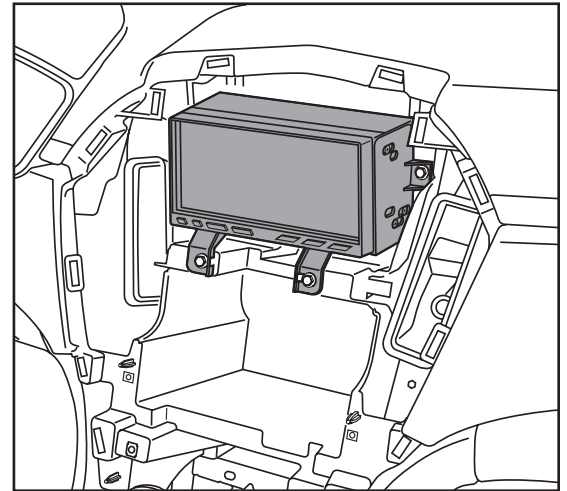

(Figure B)

KIT ASSEMBLY

Pioneer Modular DDIN radio provision

Note: For steps 1 and x, reference the installation manual provided with the radio for which hardware to use. The display screen and radio chassis use two different types of screws.

1. Secure the display screen to the **Pioneer display brackets** using (6) screws supplied with the radio. (Figure A)
2. Connect the RGB extension cable to the display, then route the cable downward where the factory radio chassis was located.

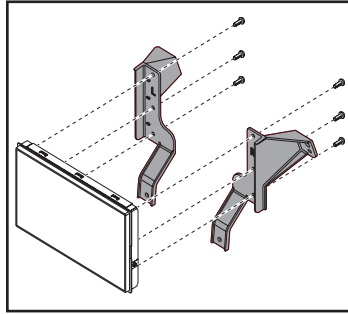

(Figure A)

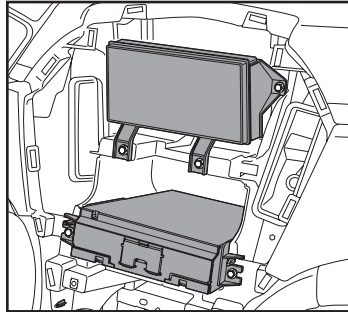

(Figure B)

3. Using the factory screws, secure the display screen assembly to the dash where the factory display was located. (Figure B)
4. Secure the **Pioneer chassis brackets** to the radio chassis using (4) screws supplied with the radio. (Figure C)
5. Using the factory screws, secure the chassis assembly to the dash where the factory chassis was located. (Figure B)

Continue to Axcess Interface Installation

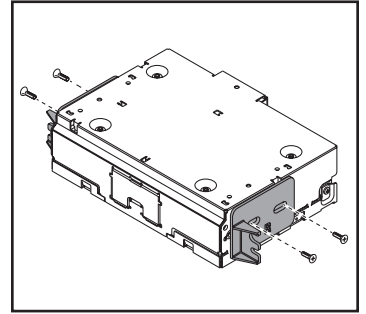

(Figure C)

AXXESS INTERFACE INSTALLATION

INTERFACE FEATURES

- Retains factory control panel and display of climate functions and vehicle customization menus on the 107-GM5B OLED screen.
- Provides accessory power (12-volt 10-amp)
- Maintains the Retained Accessory Power (R.A.P.) feature
- Provides illumination
- Provides parking brake, reverse, and speed sense outputs
- Retains audio control on steering wheel and radio control buttons on the factory control panel
- Retains warning chimes
- Retains OnStar/OE Bluetooth
- Adjustable volume for chimes and OnStar
- Can be used in non-amplified, or amplified models
- Retains balance and fade
- Micro “B” USB updatable

INTERFACE COMPONENTS

- Axxess interface
- 3”x2” OLED display
- Car side harness (LD-BX-GM8)
- Climate control T-harness (LD-SRXHVAC)
- 16-pin harness with stripped leads (LD-2NAVAMPL)
- 4-pin to 4-pin resistor pad harness (LD-GMOSTOORPAD)
- Female 3.5mm jack (LD-SWC-F3.5)
- Backup cam harness (LD-BACKUPCAM-2)

TABLE OF CONTENTS

Connections.....	10-11
Programming.....	12-13
Steering wheel control settings	14-18
Final assembly	19

TOOLS REQUIRED

- Crimping tool and connectors, or solder gun, solder, and heat shrink • Tape
- Wire cutter • Zip ties

CONNECTIONS

For models without an amplifier:

From the 16-pin harness with stripped leads to the aftermarket radio:

- Connect the **Red** wire to the accessory wire.
- If the aftermarket radio has an illumination wire, connect the **Orange/White** wire to it.
- If the aftermarket radio has a mute wire, connect the **Brown** wire to it. If the mute wire is not connected, the radio will turn off when OnStar is activated.
- Connect the **Gray** wire to the right front positive speaker output.
- Connect the **Gray/Black** wire to the right front negative speaker output.
- Connect the **White** wire to the left front positive speaker output.
- Connect the **White/Black** wire to the left front negative speaker output.

The following (3) wires are only for multimedia/navigation radios that require these wires.

- Connect the **Green/Purple** wire to the reverse wire.
- Connect the **Light Green** wire to the parking brake wire.
- Tape off and disregard the following (5) wires, they will not be used in this application:
Blue/White, Purple, Purple/Black, Green, Green/Black

From the car side harness to the aftermarket radio:

- Connect the **Black** wire to the ground wire.
- Connect the **Yellow** wire to the battery wire.
- Cut off and remove the resistors from the **Green, Green/Black, Purple, and Purple/Black** wires below the heat shrink.
- Connect the **Green** wire to the left rear positive speaker output.

- Connect the **Green/Black** wire to the left rear negative speaker output.
- Connect the **Purple** wire to the right rear positive speaker output.
- Connect the **Purple/Black** wire to the right rear negative speaker output.
- Ensure the 4-pin Molex connectors are connected together.

Note: The 4-pin to 4-pin resistor pad harness will not be used in this application.

- Connect the Blue/Pink wire to the VSS/speed sense wire.
- The **Black/Yellow** wire is used for OnStar level adjustment for models that do not come equipped with steering wheel controls. Refer to the OnStar level Adjustment section for further instructions.

Attention! If this wire is not connected the climate display will fail to display climate information.

- Connect the **Pink** wire with a red bullet connector to the **Pink** wire from the climate control T-harness.
- If retaining the factory AUX-IN jack is desired, connect the **Red** and **White** RCA jacks to the audio AUX-IN jacks from the aftermarket radio.

Note:

- a) The jack can only be used if it is a single jack.
- b) If the jack has a USB port as well, neither can be retained.

Note: The relay attached to the car side harness is only for audible turn signal clicks.

No extra steps are required to retain this feature, so leave the relay as-is.

DIN jack:

The DIN jack will not be used in this application, please disregard.

Continued on the next page

For models with an amplifier:

From the 16-pin harness with stripped leads to the aftermarket radio:

- Connect the **Red** wire to the accessory wire.
- Connect the **Blue/White** wire to the amp turn on wire. This wire must be connected to hear sound from the factory amplifier.
- If the aftermarket radio has an illumination wire, connect the **Orange/White** wire to it.
- If the aftermarket radio has a mute wire, connect the **Brown** wire to it. If the mute wire is not connected, the radio will turn off when OnStar is activated.
- Connect the **Gray** wire to the right front positive speaker output.
- Connect the **Gray/Black** wire to the right front negative speaker output.
- Connect the **White** wire to the left front positive speaker output.
- Connect the **White/Black** wire to the left front negative speaker output.

The following (3) wires are only for multimedia/navigation radios that require these wires.

- Connect the **Blue/Pink** wire to the VSS/speed sense wire.
- Connect the **Green/Purple** wire to the reverse wire.
- Connect the **Light Green** wire to the parking brake wire
- Tape off and disregard the following (4) wires, they will not be used in this application:
 - **Green, Green/Black, Purple, Purple/Black**

From the car side harness to the aftermarket radio:

- Connect the **Black** wire to the ground wire.
- Connect the **Yellow** wire to the battery wire.

- Connect the **Green** wire to the left rear positive speaker output.
- Connect the **Green/Black** wire to the left rear negative speaker output.
- Connect the **Purple** wire to the right rear positive speaker output.
- Connect the **Purple/Black** wire to the right rear negative speaker output.
- Disconnect the 4-pin Molex connectors and then attach the 4-pin to 4-pin resistor pad harness.
- The **Black/Yellow** wire is used for OnStar level adjustment for models that do not come equipped with steering wheel controls. Refer to the OnStar level Adjustment section for further instructions.

Attention! If this wire is not connected the climate control will fail to function.

- Connect the **Pink** wire with a red bullet connector to the **Pink** wire from the climate control harness
- If retaining the factory AUX-IN jack is desired, connect the **Red** and **White** RCA jacks to the audio AUX-IN jacks from the aftermarket radio.

Note:

- The jack can only be used if it is a single jack.
- If the jack has a USB port as well, neither can be retained.

Note: The relay attached to the car side harness is only for audible turn signal clicks. No extra steps are required to retain this feature, so leave the relay as-is.

DIN jack:

The DIN jack will not be used in this application, please disregard.

Continue to Programming

PROGRAMMING

With the key in the off position:

1. Connect the 16-pin harness with stripped leads, and the car side harness, into the Axxess interface.
2. Connect the climate control harness to the radio trim panel with climate controls, then to the wiring harness in the vehicle.
3. Locate the factory antenna connector in the dash and complete all necessary connections to the radio. Metra recommends using the proper antenna adapter from Metra.

Attention! Do not connect the car side harness to the wiring harness in the vehicle just yet.

PROGRAMMING THE INTERFACE

For the steps below, the L.E.D. located inside the interface can only be seen while active. The interface does not need to be opened to see the L.E.D.

- Start the vehicle.
- Connect the car side harness to the wiring harness in the vehicle. The L.E.D. will initially be solid **Green** to indicate the interface is powered.
- The L.E.D. will then flash **Red** up to (18) times indicating which radio is connected to the interface, and then turn off for a couple of seconds. Pay close attention to how many Red flashes there are. This will help in troubleshooting, if need be. Refer to the L.E.D. feedback section for more information.

- After a couple seconds the L.E.D. will turn on solid **Red** while the interface auto detects the vehicle. The radio will shut off at this point. This process should take 5 to 30 seconds.
- Once the vehicle has been auto detected by the interface, the L.E.D. will turn on solid **Green**, and the radio will come back on, indicating programming was successful.
- Test all functions of the installation for proper operation, before reassembling the dash. If the interface fails to function, refer to Resetting the interface.

Note: The L.E.D. will turn on solid **Green** for a moment, and then turn off under normal operation after the key has been cycled.

- Test all functions of the installation for proper operation, before reassembling the dash.
- If the interface fails to function, refer to “Troubleshooting”, “Resetting the Axxess interface”.

Chime level adjustment:

- With the vehicle on, turn it off and leave the keys in ignition. Open the driver’s door; chimes will be heard.
- Wait 10 seconds, and then with a small flat-blade screwdriver, turn the potentiometer clockwise to raise the chime level; counterclockwise to lower the chime level.
- When the chime is at a desired level, remove the keys from the ignition. This will lock the chime volume at its current level.

Continued on the next page

OnStar level adjustment:

- Press the OnStar button to activate it.
- While OnStar is speaking, press the VOLUME-UP or VOLUME-DOWN button on the steering wheel to raise or lower the OnStar level.
- If the vehicle doesn't come equipped with steering wheel controls, locate the **Black/Yellow** wire on the car side harness.
- While OnStar is speaking, tap the **Black/Yellow** wire to ground. Once the OnStar level is set, it will stay at that level until the **Black/Yellow** wire is tapped to ground again. L.E.D. feedback

Continue to Steering Wheel Control Settings

STEERING WHEEL CONTROL SETTINGS

L.E.D. Feedback

The (18) **Red** L.E.D. flashes represent what brand radio the interface believes it is connected to. Each flash represents a different radio Manufacturer. For example, if you are installing a JVC radio, the interface will flash (5) times, and then stop. Following is a legend that dictates which radio Manufacturer corresponds to which flash.

L.E.D. Feedback Legend

Flash Count	Radio
1	Eclipse (type 1) †
2	Kenwood ‡
3	Clarion (type 1) †
4	Sony/Dual
5	JVC
6	Pioneer/Jensen
7	Alpine *
8	Visteon
9	Valor
10	Clarion (type 2) †
11	Metra OE
12	Eclipse (type 2) †
13	LG
14	Parrot **
15	XITE
16	Philips
17	TBA
18	JBL

***Note:** If the interface flashes **Red** (7) times, and you do not have an Alpine radio connected to it, that means the interface does not detect a radio connected to it. Verify that the 3.5mm jack is connected to the correct steering wheel jack/wire in the radio.

****Note:** Part number AX-SWC-PARROT is required (sold separately). Also, the Parrot radio must have rev. 2.1.4 or higher software.

† Note: If you have a Clarion radio and the steering wheel controls do not work, change the radio type to the other Clarion radio type; same for Eclipse. The following section explains how to do this.

‡ Note: If you have a Kenwood radio and the L.E.D. feedback comes back showing as a JVC radio, change the radio type to Kenwood. The following section explains how to do this.

Continued on the next page

STEERING WHEEL CONTROL SETTINGS *(CONT.)*

Changing radio type

1. If the LED flashes do not match the radio you have connected, you must manually program the interface to tell it what radio it is connected to.
2. After (3) seconds of turning the key on, press and hold the Volume-Down button on the steering wheel until the L.E.D. in the interface goes solid.
3. Release the Volume-Down button; the L.E.D. will go out indicating we are now in Changing
4. Radio Type mode.
5. Refer to the Radio Legend to know which radio number you would like to have programmed.
6. Press and hold the Volume-Up button until the L.E.D. goes solid, and then release. Repeat this step for the desired radio number you have selected.
7. Once the desired radio number has been selected, press and hold the Volume-Down button on the steering wheel until the L.E.D. goes solid. The L.E.D. will remain on for about (3) seconds while it stores the new radio information.
8. Once the L.E.D. goes off, the **Changing Radio Type** mode will then end. You can now test the steering control wheel controls.

Note: If at any time the user fails to press any button for a period longer than (10) seconds, this process will abort.

Radio legend

- | | |
|---------------------|----------------------|
| 1. Eclipse (Type 1) | 10. Clarion (Type 2) |
| 2. Kenwood | 11. Metra OE |
| 3. Clarion (Type 1) | 12. Eclipse (Type 2) |
| 4. Sony/Dual | 13. LG |
| 5. JVC | 14. Parrot |
| 6. Pioneer/Jensen | 15. XITE |
| 7. Alpine | 16. Philips |
| 8. Visteon | 17. TBD |
| 9. Valor | 18. JBL |

Continued on the next page

STEERING WHEEL CONTROL SETTINGS (CONT.)

Dual assignment instructions (long button press)

The interface has the capability to assign (2) functions to a single button, except Volume-Up and Volume-Down. Follow the steps below to program the button(s) to your liking.

Note: Seek-Up and Seek-Down come pre-programmed as Preset-Up and Preset-Down for a long button press.

1. Turn on the ignition but do not start the vehicle.
2. Press and hold down the steering wheel control button that you want to assign a long press function to for about (10) seconds, or until the L.E.D. flashes rapidly. At this point release the button; the L.E.D. will then go solid.
3. Press and release the Volume-Up button the number of times corresponding to the new button number selected. Refer to the **Dual Assignment Legend**. The L.E.D. will flash rapidly while the Volume-Up button is being pressed, and then go back to a solid L.E.D. once released. Go to the next step once the Volume-Up button has been pressed the desired number of times.

Caution: If more than (10) seconds elapses between pressing the Volume-Up button, this procedure will abort, and the L.E.D. will go out.

4. To store the long press button in memory, press the button that you assigned a long press button to (the button held down in Step 2). The L.E.D. will now go off indicating the new information has been stored.

Note: These steps must be repeated for each button you would like to assign a dual purpose feature to. To reset a button back to its default state, repeat Step 1, and then press the Volume-Down button. The L.E.D. will go out, and the long press mapping for that button will be erased.

Dual assignment legend

- | | |
|-------------------|-----------------|
| 1. Not allowed | 10. Band |
| 2. Not allowed | 11. Play/Enter |
| 3. Seek-Up/Next | 12. PTT |
| 4. Seek-Down/Prev | 13. On-Hook |
| 5. Mode/Source | 14. Off-Hook |
| 6. ATT/Mute | 15. Fan-Up * |
| 7. Preset-Up | 16. Fan-Down * |
| 8. Preset-Down | 17. Temp-Up * |
| 9. Power | 18. Temp-Down * |

*** Not applicable in this application**

Continued on the next page

STEERING WHEEL CONTROL SETTINGS (CONT.)

Remapping the steering wheel control buttons

Let's say you have interface initialized and you want to change the button assignment for the steering wheel control buttons. For example, you would like Seek-Up to become Mute. Follow the steps below to remap the steering wheel control buttons:

1. Ensure the interface is visible so you can see the L.E.D. flashes to confirm button recognition.

Tip: Turning the radio off is recommended.

2. Within the first twenty seconds of turning the ignition on, press and hold the Volume-Up button on the steering wheel until the L.E.D. goes solid.
3. Release the Volume-Up button, the L.E.D. will then go out; The Volume-Up button has now been programmed.
4. Follow the list in the Button Assignment Legend to reference the order in which the steering wheel control buttons need to be programmed.

Note: If the next function on the list is not on the steering wheel, press the Volume-Up button for (1) second until the L.E.D. comes on, and then release the Volume-Up button. This will tell the interface that this function is not available and it will move on to the next function.

5. To complete the remapping process, press and hold the Volume-Up button on the steering wheel until the L.E.D. in the interface goes out.

Button assignment legend

- | | |
|-------------------|--------------------------|
| 1. Volume-Up | 10. Band |
| 2. Volume-Down | 11. Play/Enter |
| 3. Seek-Up/Next | 12. PTT (Push to Talk) * |
| 4. Seek-Down/Prev | 13. On-Hook * |
| 5. Source/Mode | 14. Off-Hook * |
| 6. Mute | 15. Fan-Up * |
| 7. Preset-Up | 16. Fan-Down * |
| 8. Preset-Down | 17. Temp-Up * |
| 9. Power | 18. Temp-Down * |

* Not applicable in this application

Note: Not all radios will have all of these commands. Please refer to the manual provided with the radio, or contact the radio manufacturer for specific commands recognized by that particular radio.

Continued on the next page

STEERING WHEEL CONTROL SETTINGS *(CONT.)*

The factory vehicle customization menu is visible on the Metra 107-GM5B screen with use of the factory Center stack buttons. Some buttons also double as additional radio controls (just like the steering wheel controls).

Factory buttons on Non NAV models:

Seek >> – seek up

Seek << - seek down

Radio/band – source

Menu/select- enters menu mode. Also enter button

Silver dial – scrolls through menu options

Back = back

Factory buttons on NAV models:

Seek >> – seek up

Seek << - seek down

CD/AUX/HDD – source

Menu/select- enters menu mode. Also enter button

Silver dial – scrolls through menu options

Back= back

FINAL ASSEMBLY

1. Reassemble the dash in reverse order of disassembly to complete the installation.



107-GM5B

INSTALLATION INSTRUCTIONS



Having difficulties? We're here to help.



Contact our Tech Support line at:

386-257-1187



Or via email at:

techsupport@metra-autosound.com

Tech Support Hours (Eastern Standard Time)

Monday - Friday: 9:00 AM - 7:00 PM

Saturday: 10:00 AM - 7:00 PM

Sunday: 10:00 AM - 4:00 PM



KNOWLEDGE IS POWER

Enhance your installation and fabrication skills by enrolling in the most recognized and respected mobile electronics school in our industry. Log onto www.installerinstitute.com or call 800-354-6782 for more information and take steps toward a better tomorrow.



Metra recommends MECP certified technicians