



INSTALLATION INSTRUCTIONS FOR PART 95-7315

APPLICATIONS

Hyundai Tucson 2005-2009

95-7315

KIT FEATURES

- DDIN Head Unit Provision
- ISO Stacked Head Unit Provision

KIT COMPONENTS

- A) Double DIN Trim Plate • B) Double DIN Brackets

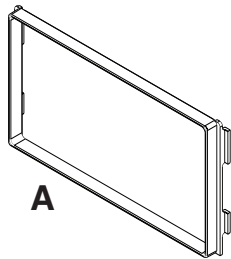

A

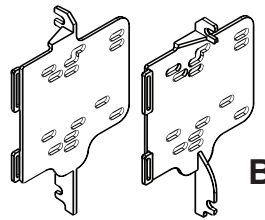

B

WIRING AND ANTENNA CONNECTIONS (Sold Separately)

Harness: 70-7301 - KIA / HYUNDAI 1999-2008 Harness

Antenna Adapter: Not Required

TOOLS REQUIRED:

Small Flat Blade Screwdriver /Panel Removal Tool • Phillips Screwdriver



1-800-221-0932



www.metraonline.com

© COPYRIGHT 2004-2009 METRA ELECTRONICS CORPORATION



95-7315

TABLE OF CONTENTS

<i>Dash Disassembly</i>	1-2
<i>Kit Assembly</i>	3



KNOWLEDGE IS POWER

Enhance your installation and fabrication skills by enrolling in the most recognized and respected mobile electronics school in our industry. Log onto www.installerinstitute.com or call 800-354-6782 for more information and take steps toward a better tomorrow.

2005-2009 HYUNDAI TUCSON

- 1** Disconnect the negative battery terminal to prevent an accidental short circuit.
- 2** Remove screw cover from back side of shift knob and remove (2) Phillips screws. Lift straight up on shift knob to remove. (Figure A)
- 3** Unclip and remove shift knob trim panel. (Figure B)
- 4** Remove (10) Phillips screws from dash support under shift knob trim panel and remove. (Figure C)

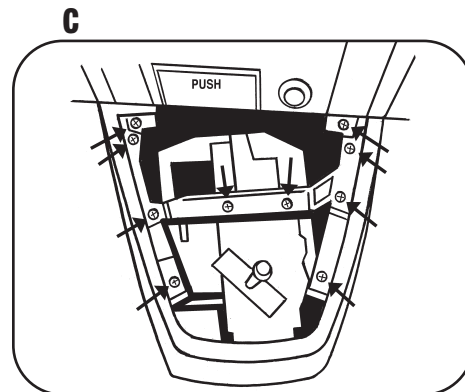
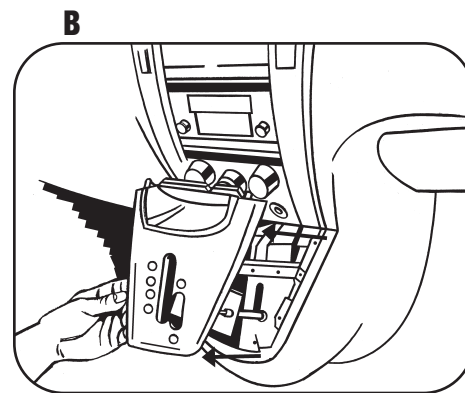
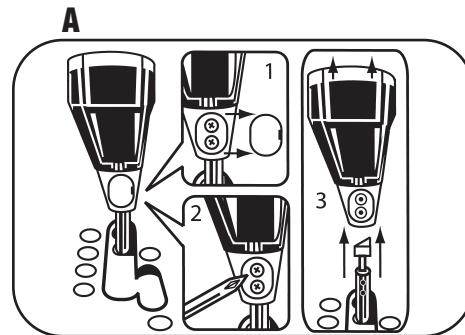

DASH DISASSEMBLY

DASH DISASSEMBLY**2005-2009 HYUNDAI TUCSON**

- 5** Remove (1) Phillips screw from bottom center of trim panel surrounding radio including a/c controls then unclip and remove panel. (Figure D-E)

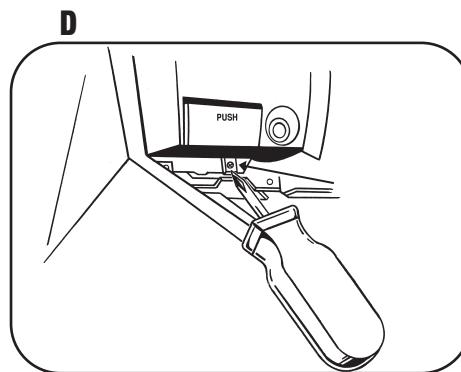

- 6** Remove (4) Phillips screws to remove radio. (Figure F)

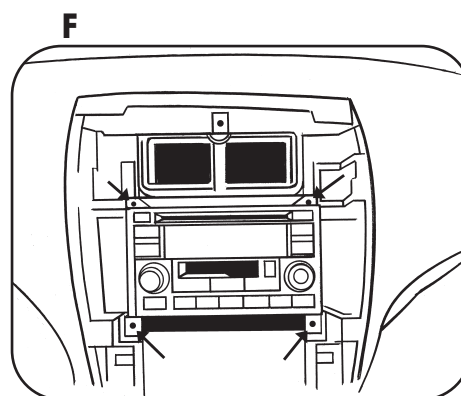
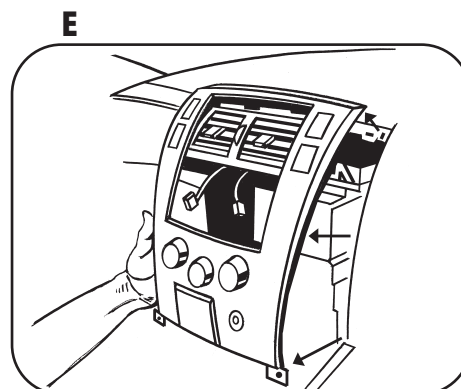

DOUBLE DIN HEAD UNIT PROVISION/ STACKED ISO DIN HEAD UNIT PROVISION

- 1** Locate the factory wiring harness in the dash. Metra recommends using the proper mating adapter from Metra or AXXESS. Re-connect the negative battery terminal and test the unit for proper operation.
- 2** Snap the Double DIN brackets to the Double DIN trim plate. (Figure A)
- 3** Slide the Double DIN head unit or stacked ISO head units into the bracket/trim plate assembly and secure the Double DIN head unit or stacked ISO head units to the assembly using the screws supplied with the radio. (Figure B)
- 4** Reassemble dash in reverse order of disassembly.

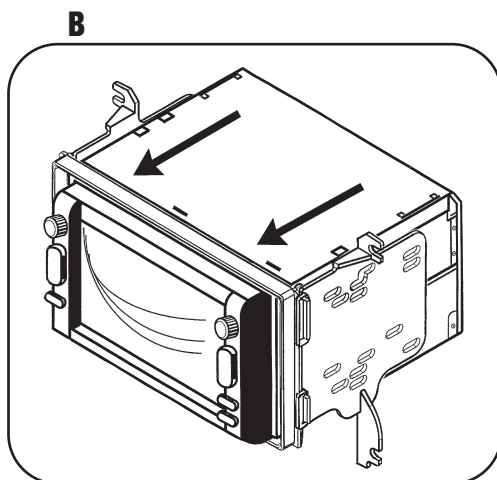
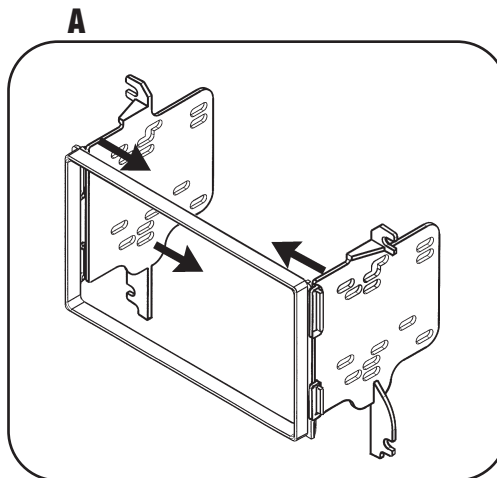

KIT ASSEMBLY

INST95-7315



1-800-221-0932



www.metraonline.com

REV. 08-04-09

© COPYRIGHT 2004-2009 METRA ELECTRONICS CORPORATION

INST95-7315