

KIT FEATURES

- ▶ Shaft and DIN unit provisions

KIT COMPONENTS

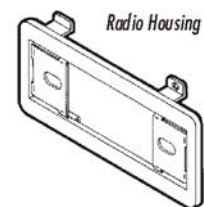

TOOLS REQUIRED



Phillips screwdriver



Cutting tool



Socket wrench

99-1000 INSTALLATION INSTRUCTIONS

APPLICATIONS

CAR	PAGE
CHRYSLER	
Sebring 1995-00.....	1
DODGE	
Avenger 1995-00.....	1
JEEP	
Grand Cherokee 1993-95.....	1



CHRYSLER Sebring / DODGE Avenger 1995-00

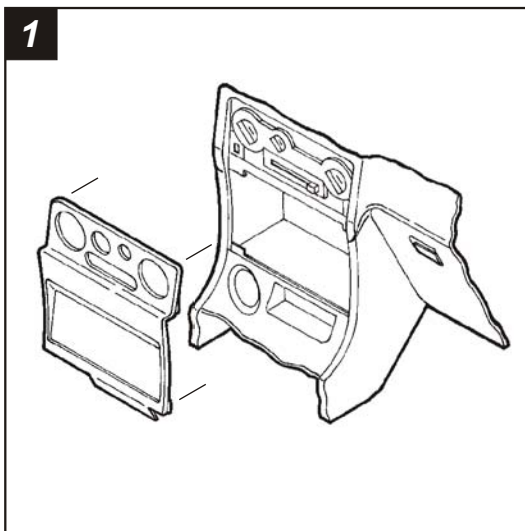

1 Disconnect the negative battery terminal to prevent an accidental short circuit. Unclip and remove the radio trim bezel. Remove (2) #10 Phillips screws from the factory radio, slide the radio out and disconnect the wiring. *Skip to the Installation Instructions for ALL VEHICLES on Page #2.*

ALL VEHICLES

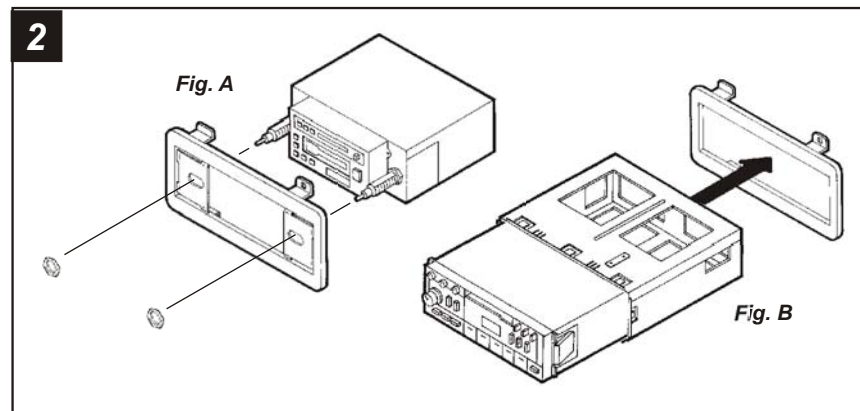

2 **2-SHAFT HEAD UNITS:** Slide the aftermarket head unit into the kit and secure with shaft nuts. (see Fig. A)

DIN HEAD UNITS: Cut and remove the shaft supports. Slide the DIN cage into the **Radio Housing** and secure by bending the metal locking tabs down. Slide the aftermarket head unit into the cage until secure. (see Fig. B)

JEEP Grand Cherokee 1993-95

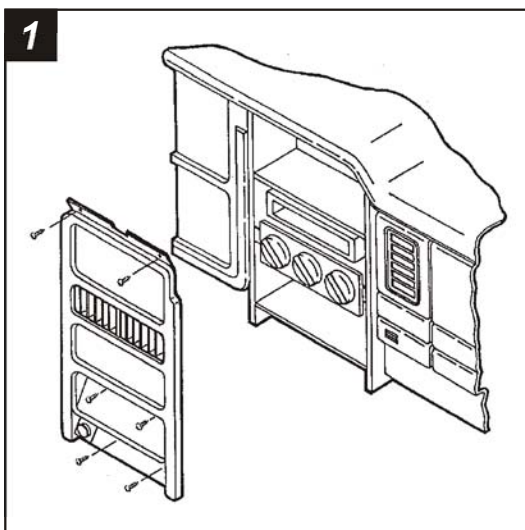

1 Disconnect the negative battery terminal to prevent an accidental short circuit. Remove (2) Phillips screws from the bottom of the radio trim bezel. Remove (2) Phillips screws above the radio opening. Remove (2) Phillips screws located to the left of the steering column and (1) screw located to the right. Unclip and remove the radio trim bezel. Remove (2) hex-head screws from the factory head unit, slide the unit out and disconnect the wiring. *Skip to the Installation Instructions for ALL VEHICLES on Page #2.*

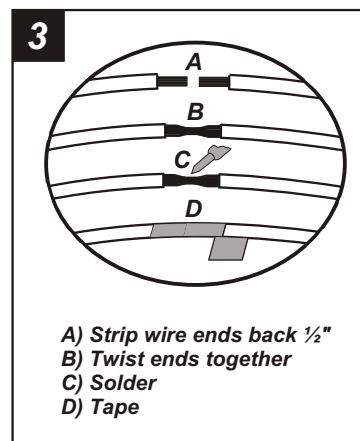

A) Strip wire ends back 1/2"
B) Twist ends together
C) Solder
D) Tape

3 Locate the factory wiring harness in the dash. Metra recommends using the proper mating adaptor and making connections as shown. (Isolate and individually tape off the ends of any unused wires to prevent electrical short circuit).

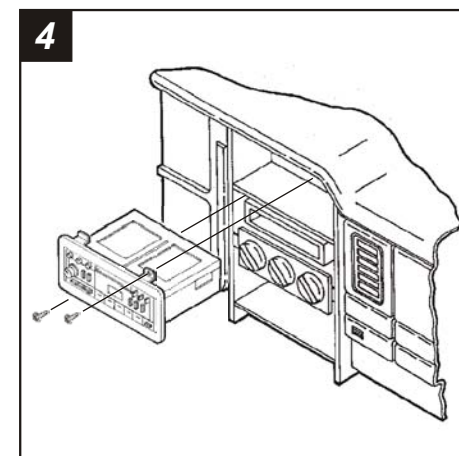

4 Re-connect the battery terminal and test the unit for proper operation. Mount the head unit/kit assembly to the sub-dash with the (2) factory screws removed in step #1.