



INSTALLATION INSTRUCTIONS FOR PART 99-2010

APPLICATIONS

2005-2010 Cadillac STS 99-2010

KIT FEATURES

- ISO radio provision with pocket
- Double DIN radio provision
- Painted matte black to match OEM finish



KIT COMPONENTS

- A) Radio Housing • B) Radio Housing Trim Plate • C) Radio Housing Brackets • D) Pocket
E) 4) #8x3/8" Screws

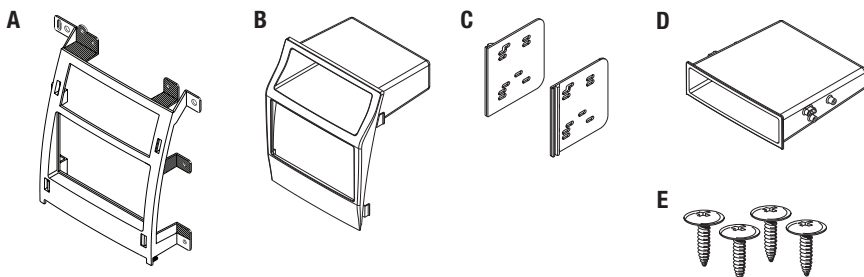

WIRING & ANTENNA CONNECTIONS (Sold Separately)

Antenna Adapter: • 40-CR10 - 2002-up Chrysler/GM

TOOLS REQUIRED

Small Flat Blade Screwdriver • Panel Removal Tool • Phillips Screwdriver • Socket Wrench



METRA. THE WORLD'S BEST KITS.™



1-800-221-0932



metraonline.com

© COPYRIGHT 2004-2011 METRA ELECTRONICS CORPORATION



99-2010

Table of Contents

Dash Disassembly

– Cadillac STS 2005-2010.....3

Kit Assembly

– Kit preparation.....4
– ISO DIN head unit provision5-6
– Double DIN head unit provision7

Caution

Metra recommends disconnecting the negative battery terminal before beginning any installation. All accessories, switches, and especially air bag indicator lights must be plugged in before reconnecting the battery or cycling the ignition.

**NOTE: Refer also to the instructions included with the aftermarket radio.*



KNOWLEDGE IS POWER

Enhance your installation and fabrication skills by enrolling in the most recognized and respected mobile electronics school in our industry. Log onto www.installerinstitute.com or call 800-354-6782 for more information and take steps toward a better tomorrow.



Metra recommends MECP certified technicians

Dash Disassembly

1. Unclip and remove the entire panel surrounding the radio including the a/c vents. (Figure A)
2. Remove (4) 10mm bolts to extract radio from dash. (Figure B)

Continued to kit preparation

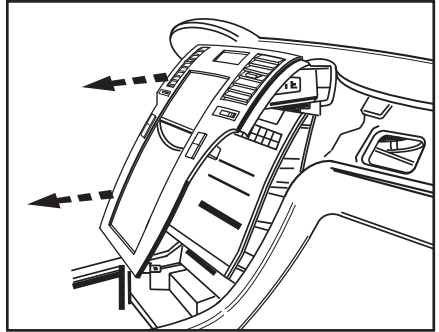

(Figure A)

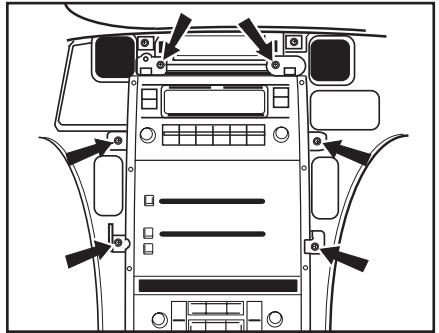

(Figure B)

Kit Preparation

1. Cut and remove the shaded areas marked with an “E” only from the radio housing. (Figure A) Right side and top of radio housing. (Figure B) Left side and top of radio housing.

NOTE: DO NOT remove the tab marked with both “S” and “E”.

Continue to kit assembly.

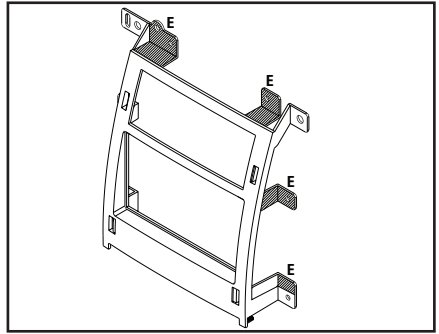

(Figure A)

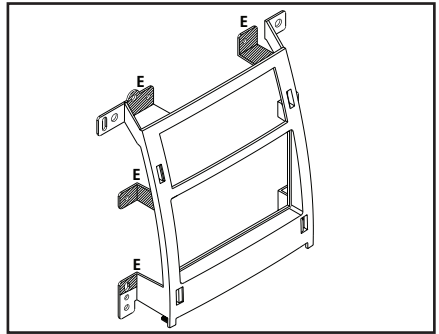

(Figure B)



Kit Assembly 99-2010

ISO mount radio provision with pocket

1. Locate the factory wiring harness in the dash. Metra recommends using the proper mating adapter from Metra or AXXESS. Re-connect the negative battery terminal and test the unit for proper operation.
2. Flip the radio housing brackets upside down then snap them to the inside edge of the radio housing. (Figure A)
3. Slide the pocket into the top of the opening aligning the holes in the radio housing brackets with the bosses on the pocket and secure using the provided (4) #8 x 3/8" screws. (Figure B)
4. Slide the ISO radio into the opening below the pocket and secure the unit to the kit using the screws supplied with the radio. (Figure C)

Continue to next page.

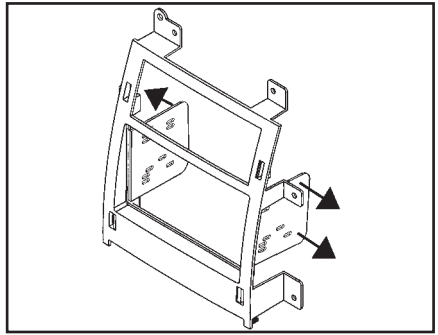

(Figure A)

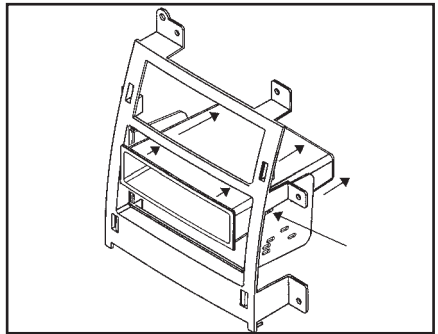

(Figure B)

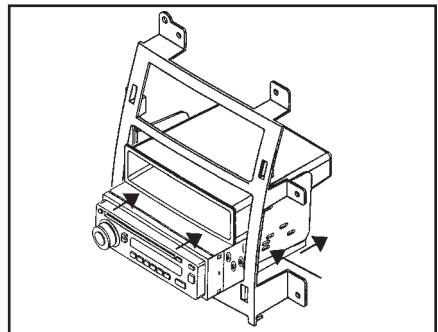

(Figure C)



Kit Assembly 99-2010

ISO mount radio provision with pocket

5. Snap the radio housing trim plate onto the front of the radio housing.
(Figure D)
6. Reassemble dash in reverse order of disassembly.

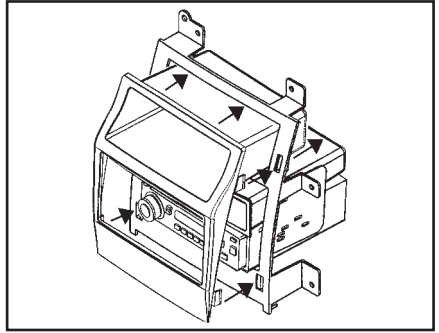

(Figure D)



Kit Assembly 99-2010

Double DIN Radio provision

1. Locate the factory wiring harness in the dash. Metra recommends using the proper mating adapter from Metra or AXXESS. Re-connect the negative battery terminal and test the unit for proper operation.
2. Snap the radio housing brackets to the inside edge of the double DIN trim plate. (Figure A)
3. Slide the double DIN head unit or stacked ISO head units into the bracket/radio housing assembly and secure the double DIN head unit or stacked ISO head units to the assembly using the screws supplied with the radio. (Figure B)
4. Snap the radio housing trim plate onto the front of the radio housing. (Figure C)
5. Reassemble dash in reverse order of disassembly.

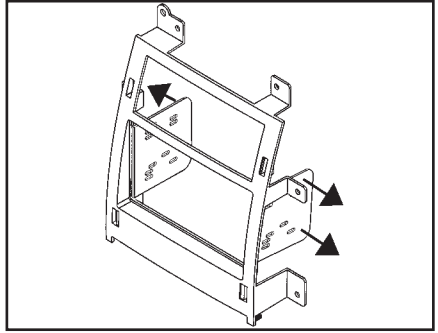

(Figure A)

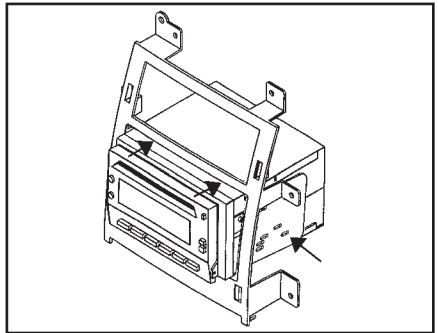

(Figure B)

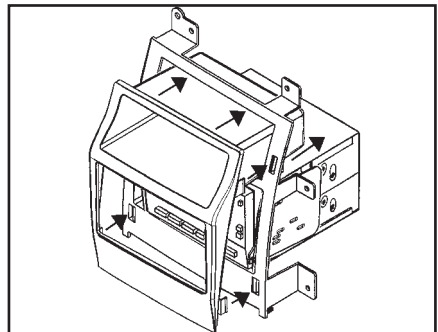

(Figure C)



INSTALLATION INSTRUCTIONS FOR PART 99-2010

REV. 6/15/11

METRA. THE WORLD'S BEST KITS.™



1-800-221-0932



metraonline.com

© COPYRIGHT 2004-2011 METRA ELECTRONICS CORPORATION