



INSTALLATION INSTRUCTIONS FOR PART 99-3200

APPLICATIONS

Chevrolet/Buick 1991-1996 99-3200

KIT FEATURES

- DIN head unit provision
- Rear support provision

KIT COMPONENTS

- A) Radio housing • B) Rear support • C) Offset rear support

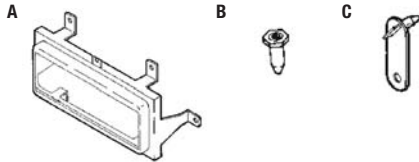

WIRING & ANTENNA CONNECTIONS (sold separately)

- Wiring Harness: • 70-1858 - GM harness for select 1987-2005
 Antenna Adapter: • 40-GM10 - Select 1983-2013 GM vehicles

TOOLS REQUIRED

- Phillips screwdriver • Utility knife • Socket wrench

Table of Contents

Dash Disassembly

– Buick Roadmaster 1991-1994	2
– Chevrolet Beretta 1991-1996.....	2
– Chevrolet Cavalier 1991-1994.....	3
– Chevrolet Caprice 1991-1993	2
– Chevrolet Corsica 1991-1996.....	2

Kit Assembly

– DIN head unit provision	3
– Rear support provision.....	3

CAUTION: Metra recommends disconnecting the negative battery terminal before beginning any installation. All accessories, switches, and especially air bag indicator lights must be plugged in before reconnecting the battery or cycling the ignition.

NOTE: Refer to the instructions included with the aftermarket radio.



Dash Disassembly 99-3200

Chevrolet Beretta/Corsica 1991-1996

1. Using a panel removal tool, pry out on the dash trim bezel and remove.
2. Remove (2) screws securing the factory head unit and disconnect the wiring. (Figure A)
3. Cut and remove all mounting tabs on the Radio Housing EXCEPT tabs "B". (Figure B)

Note: The mounting tabs can be identified by the stamped letter on the back of each tab.

Continue to kit assembly

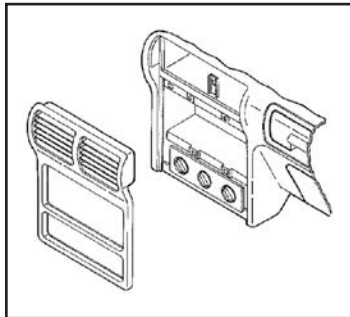

(Figure A)

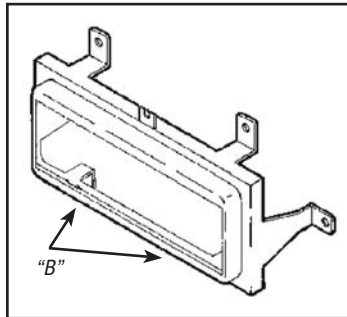

(Figure B)

Buick Roadmaster 1991-1994 Chevrolet Caprice 1991-1993

1. Remove (2) screws from the driver's side service panel and unclip the panel.
2. Pry off the trim piece located above the glove box and remove (1) screw.
3. Remove (3) screws from the top edge of the dash trim bezel. Remove (1) screw from the lower-left corner of the glove box and (1) screw from the parking brake release. Remove the dash trim bezel. Remove (3) 9/32" hex-head screws securing the factory head unit and disconnect the wiring. (Figure A)
4. Cut and remove all mounting tabs on the Radio Housing EXCEPT tabs "A". (Figure B)

Continue to kit assembly

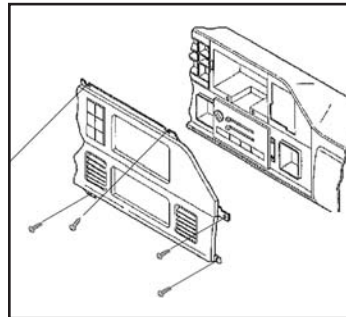

(Figure A)

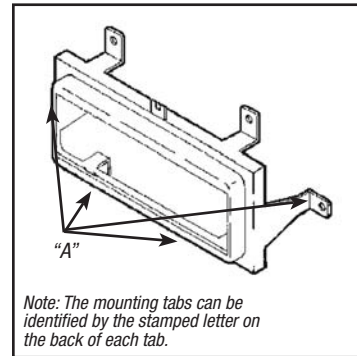

(Figure B)



Chevrolet Cavalier 1991-1994

1. Using a panel removal tool, pry out on the dash trim bezel and remove.
2. Remove (2) screws securing the factory head unit and disconnect the wiring. (Figure A)
3. Cut and remove all mounting tabs on the Radio Housing EXCEPT tabs "C". (Figure B)

Continue to kit assembly

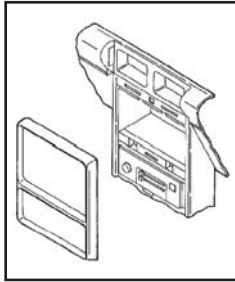

(Figure A)

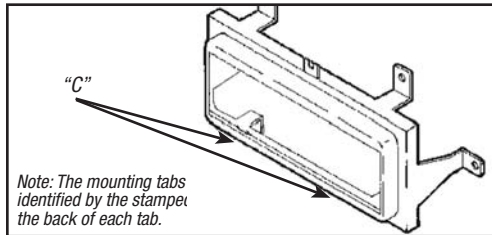

(Figure B)

DIN head unit provision:

1. Cut and remove the shaft supports from the Replacement Bezel.
2. Slide the DIN cage into the kit and secure by bending the metal locking tabs down.
3. Slide the aftermarket head unit into the cage until secure. (Figure B)

Beretta, Corsica, Cavalier:

4. Mount the Rear Support Bullet to the back of the aftermarket head unit using the hardware included with the unit.
5. Locate the factory wiring

All Vehicles

- harness in the dash. Metra recommends using the proper mating adapter from Metra or AXCESS. Re-connect the negative battery terminal and test the unit for proper operation.
6. Mount the head unit/kit assembly to the sub-dash with the screws previously removed.
 7. Reassemble dash in reverse order of disassembly.

Caprice, Roadmaster:

4. Mount the Offset Rear Support to the back of the aftermarket head unit using the hardware included with the unit.

5. Locate the factory wiring harness in the dash. Metra recommends using the proper mating adapter from Metra or AXCESS. Re-connect the negative battery terminal and test the unit for proper operation.
6. Mount the head unit/kit assembly to the sub-dash with (3) 9/32" hex-head screws previously removed ("A") and (1) 9/32" hex head screw securing the edge of the instrument cluster. ("B")
7. Reassemble dash in reverse order of disassembly.

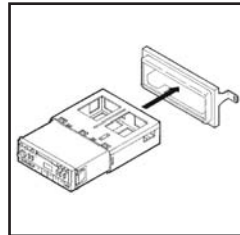

(Figure A)

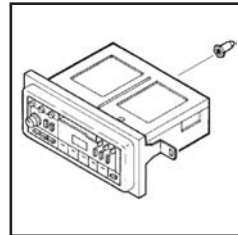

(Figure B)

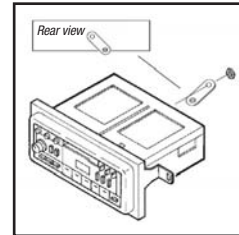

(Figure C)

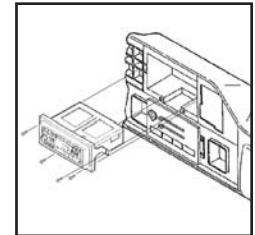

(Figure D)



INSTALLATION INSTRUCTIONS FOR PART 99-3200

REV. 3/20/2013 INST99-3200



KNOWLEDGE IS POWER

Enhance your installation and fabrication skills by enrolling in the most recognized and respected mobile electronics school in our industry. Log onto www.installerinstitute.com or call 800-354-6782 for more information and take steps toward a better tomorrow.



**Metra recommends MECP
certified technicians**