



Installation instructions for 99-3320

Pontiac multi-kit 1993-2003 99-3320

KIT FEATURES

- DIN radio provision



KIT COMPONENTS

- A) Radio housing • B) (1) Phillips pan-head screw

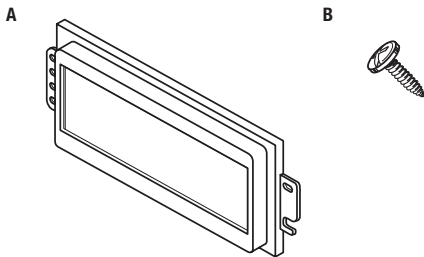

WIRING & ANTENNA CONNECTIONS (sold separately)

Wiring Harness:

- 70-1858

Antenna Adapter:

- 40-GM10

TOOLS REQUIRED

- Phillips screwdriver • Cutting tool
- Socket wrench

CAUTION: Metra recommends disconnecting the negative battery terminal before beginning any installation. All accessories, switches, and especially air bag indicator lights must be plugged in before reconnecting the battery or cycling the ignition.

NOTE: Refer to the instructions included with the aftermarket radio.

Table of Contents

Dash Disassembly

- Pontiac Bonneville 1994-19992
- Pontiac Firebird/Firebird Trans Am 1993-2002.....5
- Pontiac Grand Am 1996-19983
- Pontiac Grand Am 1999-20003
- Pontiac Grand Prix 1994-19964
- Pontiac Grand Prix 1997-20034
- Pontiac Sunfire 1995-19995

Kit Assembly

- DIN radio provision.....6

Dash Assembly

- All vehicles.....7

Pontiac Bonneville 1994-1999

1. Unclip the right side of the dash trim bezel.
2. Unclip the left side of the bezel and remove.
3. Remove (3) 7mm hex-head screws securing the factory radio and disconnect the wiring.

Continue to kit assembly

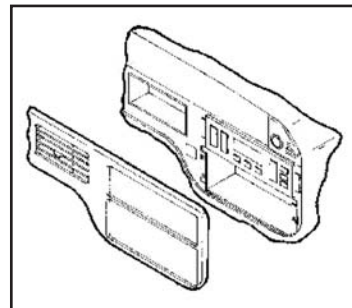

(Figure A)

Pontiac Grand Am 1996-1998

1. Remove (2) Phillips screws from the pocket.
2. Remove (2) Phillips screws above the instrument cluster.
3. Unclip the dash trim bezel and remove.
4. Remove (3) 7mm hex-head screws securing the factory radio and disconnect the wiring.

Continue to kit assembly

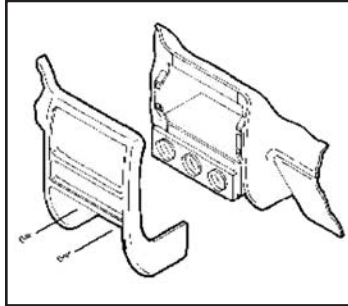

(Figure A)

Pontiac Grand Am 1999-2000

1. Unclip the radio trim bezel. (Figure A)
2. Remove (3) 9/32" screws securing the factory radio and disconnect the wiring.

Continue to kit assembly

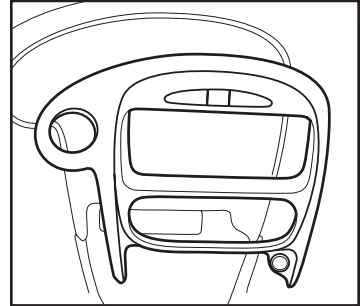

(Figure A)

Pontiac Grand Prix 1994-1996

1. Using a small set of pliers, grasp the retaining clip on the back of the gear shifter handle and remove the clip.
2. Remove the gear shifter handle.
3. Unclip the center console and remove.
4. Remove (2) 7mm hex-head screws exposed under the climate controls.
5. Unclip the radio trim bezel and remove.
6. Remove (2) 7mm hex-head screws securing the factory radio and disconnect the wiring.

Continue to kit assembly

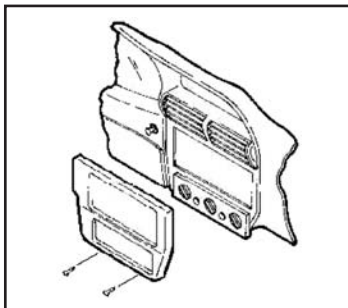

(Figure A)

Pontiac Grand Prix 1997-2003

1. Unclip the entire dash trim bezel.
2. Remove the screws securing the factory radio and disconnect the wiring.

Continue to kit assembly

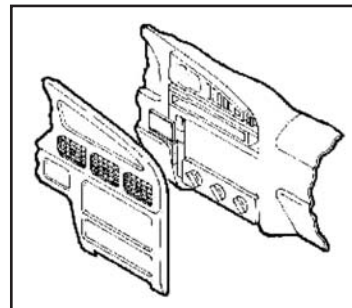

(Figure A)

Pontiac Sunfire 1995-1999

1. Open the glove box and remove (2) Phillips screws exposed on the right edge of the radio trim bezel.
2. Unclip the bezel and remove.
3. Remove (2) 7mm hex-head screws securing the factory radio and disconnect the wiring.

Continue to kit assembly

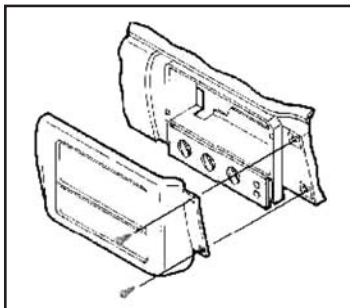

(Figure A)

Pontiac Firebird/ Firebird Trans Am 1993-2002

1. Unclip the radio trim bezel.
2. Remove (4) 7mm hex-head screws securing the factory radio and disconnect the wiring.

Continue to kit assembly

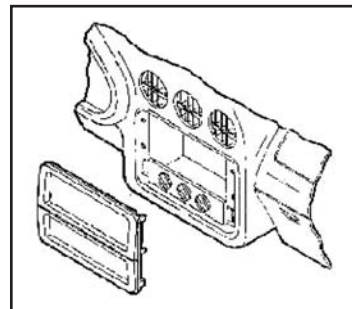

(Figure A)



Kit Assembly 99-3320

DIN radio provision

1. Slide the aftermarket radio's "metal" DIN sleeve into the radio housing. Then secure it to the housing by bending the metal locking tabs outward. (Figure A)
2. Slide the aftermarket radio into the completed assembly until it clicks in. (Figure B)
3. Locate the factory wiring harness in the dash. Metra recommends using the proper mating adapter from Metra or AXXESS. Re-connect the negative battery terminal and test the radio for proper operation.

Continue to dash assembly

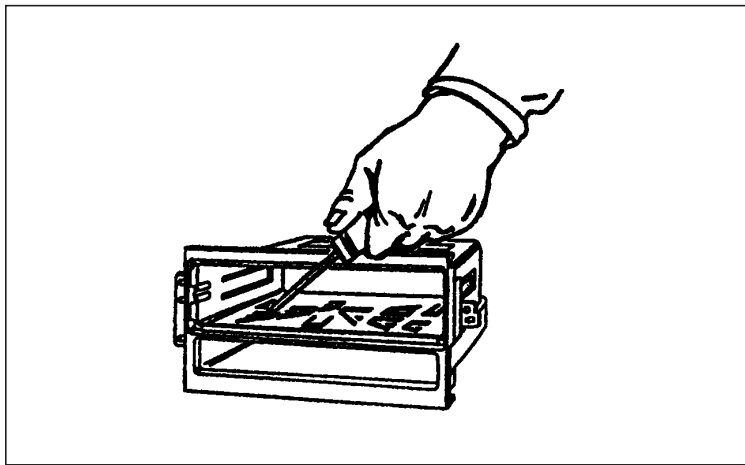

(Figure A)

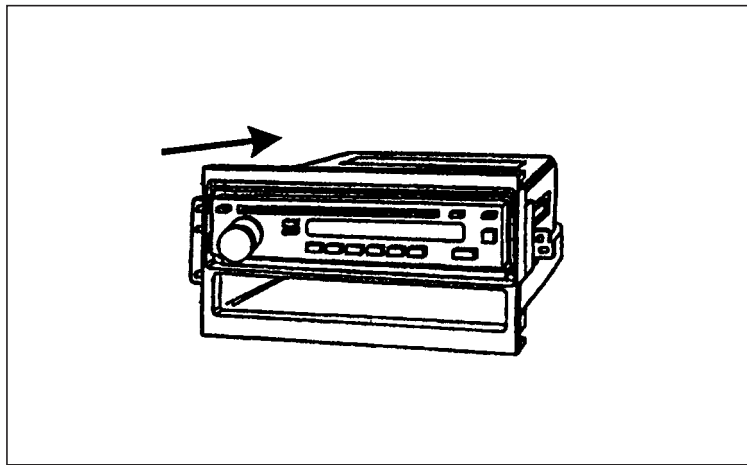

(Figure B)



Dash Assembly 99-3320

All vehicles

Bonneville 1994-1999

Position the kit as indicated and mount the completed assembly to the sub-dash with (3) 7mm hex-head screws previously removed. (Figure A)

Firebird/Firebird Trans Am 1993

Mount the completed assembly to the sub-dash with (4) 7mm hex-head screws previously removed.

Firebird/Firebird Trans Am 1994-2002

Mount the completed assembly to the sub-dash with (3) 7mm hex-head screws previously removed.

Grand Am 1996-2000

Position the kit as indicated and mount the completed assembly to the sub-dash with (3) 7mm hex-head screws previously removed. (Figure B)

Grand Prix 1994-2003

Position the kit as indicated and mount the completed assembly to the sub-dash with (2) 7mm hex-head screws previously removed. (Figure C)

Sunfire 1995-1999

Position the kit as indicated and mount the completed assembly to the sub-dash with (1) 7mm hex-head screw previously removed and (1) supplied Phillips pan-head screw. (Figure D)

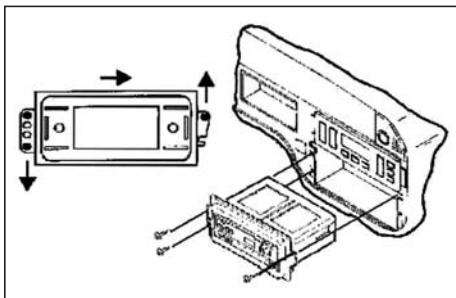

(Figure A)

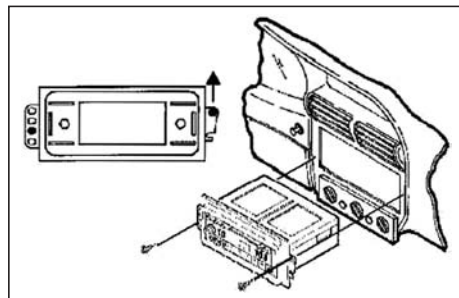

(Figure C)

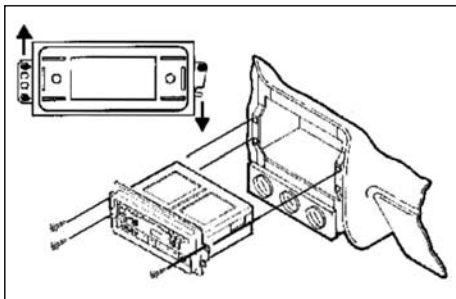

(Figure B)

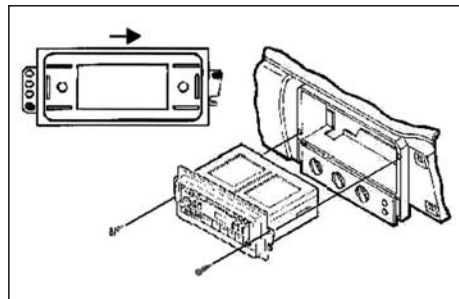

(Figure D)



Installation instructions for 99-3320



REV 12/2/2014 INST99-3320



KNOWLEDGE IS POWER

Enhance your installation and fabrication skills by enrolling in the most recognized and respected mobile electronics school in our industry. Log onto www.installerinstitute.com or call 800-354-6782 for more information and take steps toward a better tomorrow.



**Metra recommends MECP
certified technicians**



Instrucciones de instalación para 99-3320

Pontiac multi-kit 1993-2003 99-3320

CARACTERÍSTICAS DEL KIT

- Provisión de radio DIN



COMPONENTES DEL KIT

- A) Alojamiento del radio • B) (1) Tornillo Phillips de cabeza de cono achatado

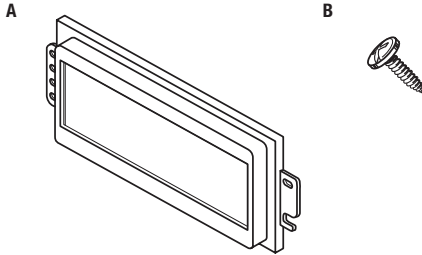

CABLEADO Y CONEXIONES DE ANTENA

Arnés de cableado: (se venden por separado)

- 70-1858

Adaptador de antena:

- 40-GM10

HERRAMIENTAS REQUERIDAS

- Destornillador Phillips • Herramienta de corte
- Llave de tubo

PRECAUCIÓN: Metra recomienda desconectar el terminal negativo de la batería antes de comenzar cualquier instalación. Todos los accesorios, interruptores y, especialmente, las luces indicadoras de airbag deben estar enchufados antes de volver a conectar la batería a comenzar el ciclo de ignición.

NOTA: Remítase a las instrucciones incluidas con el radio de postventa.

Indice

Desmontaje del tablero

- Pontiac Bonneville 1994-19992
- Pontiac Firebird/Firebird Trans Am 1993-2002.....5
- Pontiac Grand Am 1996-19983
- Pontiac Grand Am 1999-20003
- Pontiac Grand Prix 1994-19964
- Pontiac Grand Prix 1997-20034
- Pontiac Sunfire 1995-19995

Ensamble del kit

- Provisión de radio DIN6

Ensamble del tablero

- Todos los vehículos7

Pontiac Bonneville 1994-1999

1. Desenganche el lado derecho del marco de terminación del tablero.
2. Desenganche el lado izquierdo del marco y retírelo.
3. Retire (3) tornillos de cabeza hexagonal de 7 mm que sujetan la unidad central de fábrica y desconecte el cableado.

Continuará al ensamble del kit

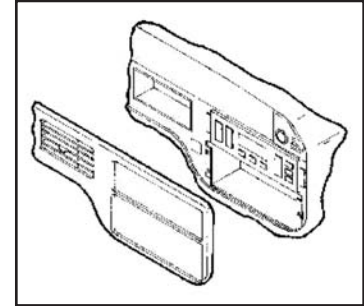

(Figura A)

Pontiac Grand Am 1996-1998

1. Retire (2) tornillos Phillips del bolsillo.
2. Retire (2) tornillos Phillips que se encuentran arriba del grupo de instrumentos.
3. Desenganche el marco de terminación del tablero y retirelo.
4. Retire (3) tornillos de cabeza hexagonal de 7 mm que sujetan la unidad central de fábrica y desconecte el cableado.

Continuará al ensamble del kit

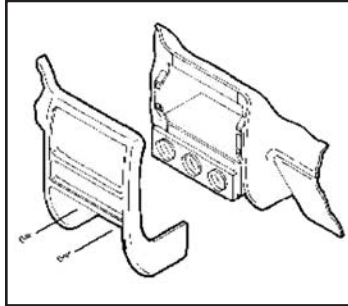

(Figura A)

Pontiac Grand Am 1999-2000

1. Desenganche el marco de terminación del radio. (Figura A)
2. Retire (3) tornillos de 9/32 in que sujetan la unidad central de fábrica y desconecte el cableado.

Continuará al ensamble del kit

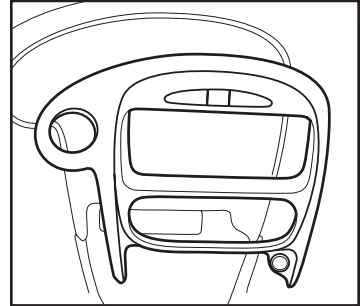

(Figura A)

Pontiac Grand Prix 1994-1996

1. Utilizando una pinza pequeña, sujete el gancho de retención en la parte posterior de la manivela de la palanca de velocidades y retire el gancho.
2. Retire la manivela de la palanca de velocidades.
3. Desenganche la consola central y retírela.
4. Retire (2) tornillos de cabeza hexagonal de 7 mm expuestos que se encuentran debajo de los controles de clima.
5. Desenganche el marco de terminación del radio y retírelo.
6. Retire (2) tornillos de cabeza hexagonal de 7 mm que sujetan la unidad central de fábrica y desconecte el cableado.

Continuará al ensamble del kit

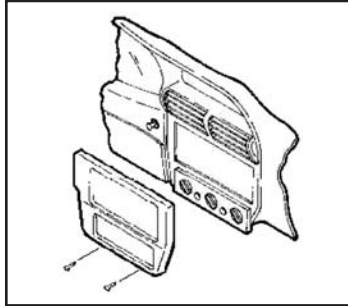

(Figura A)

Pontiac Grand Prix 1997-2003

1. Desenganche todo el marco de terminación del tablero.
2. Retire los tornillos que sujetan la unidad central de fábrica y desconecte el cableado.

Continuará al ensamble del kit

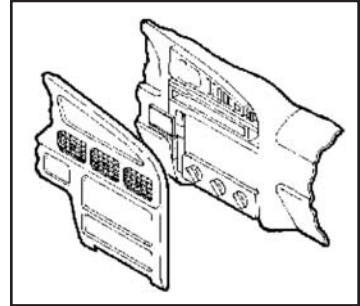

(Figura A)

Pontiac Sunfire 1995-1999

1. Abra la guantera y retire (2) tornillos Phillips expuestos en el borde derecho del marco de terminación del radio.
2. Desenganche el marco y retírelo.
3. Retire (2) tornillos de cabeza hexagonal de 7 mm que sujetan la unidad central de fábrica y desconecte el cableado.

Continuará al ensamble del kit

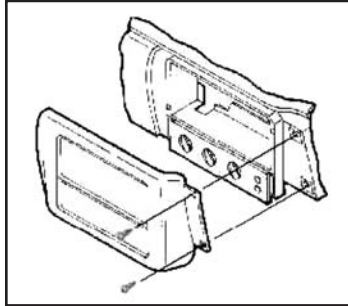

(Figura A)

Pontiac Firebird/ Firebird Trans Am 1993-2002

1. Desenganche el marco de terminación del radio.
2. Retire (4) tornillos de cabeza hexagonal de 7 mm que sujetan la unidad central de fábrica y desconecte el cableado.

Continuará al ensamble del kit

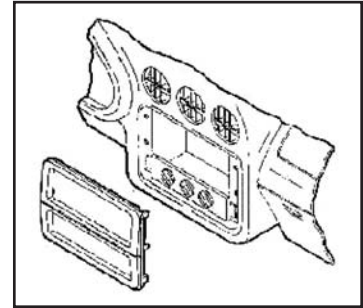

(Figura A)

Provisión de radio DIN

1. Deslice la manga DIN “metal” de la radio no original en la carcasa de la radio. Entonces fíjalo a la vivienda, doblando las lengüetas de fijación de metal hacia afuera. (Figura A)
2. Deslice la radio no original en el conjunto terminado hasta que haga clic en. (Figura B)
3. Ubique el arnés del cableado de fábrica en el tablero. Metra recomienda usar el adaptador de acoplamiento adecuado de Metra o AXXESS. Vuelva a conectar el terminal negativo de la batería y pruebe la unidad para verificar que funcione correctamente.
Continuará al ensamble del tablero

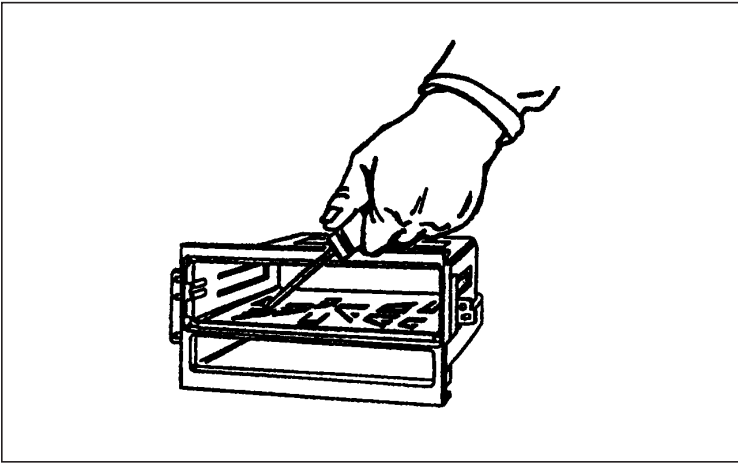

(Figura A)

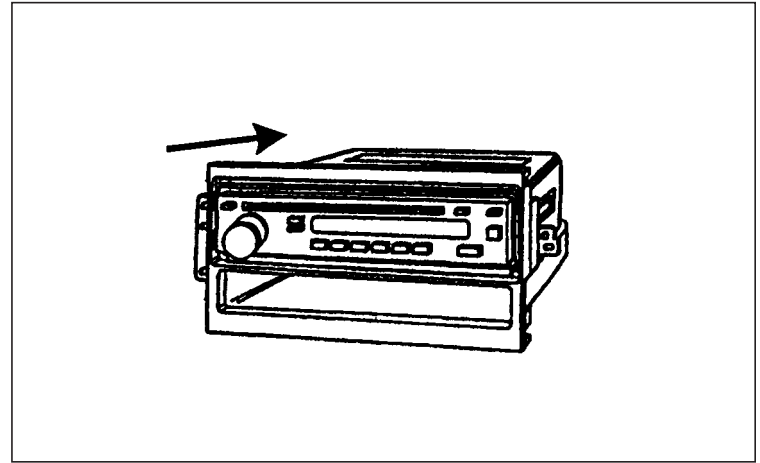

(Figura B)

Todos los vehículos**Bonneville 1994-1999**

Coloque el kit según se indica y monte el conjunto de unidad central/kit en el subtablero con (3) tornillos de cabeza hexagonal de 7 mm que retiró previamente. (Figura A)

Firebird/Firebird Trans Am 1993

Monte el conjunto de unidad central/kit en el subtablero con (4) tornillos de cabeza hexagonal de 7 mm que retiró previamente.

Firebird/Firebird Trans Am 1994-2002

Monte el conjunto de unidad central/kit en el subtablero con (3) tornillos de cabeza hexagonal de 7 mm que retiró previamente.

Grand Am 1996-2000

Coloque el kit según se indica y monte el conjunto de unidad central/kit en el subtablero con (3) tornillos de cabeza hexagonal de 7 mm que retiró previamente. (Figura B)

Grand Prix 1994-2003

Coloque el kit según se indica y monte el conjunto de unidad central/kit en el subtablero con (2) tornillos de cabeza hexagonal de 7 mm que retiró previamente. (Figura C)

Sunfire 1995-1999

Coloque el kit según se indica y monte el conjunto de unidad central/kit en el subtablero con (1) tornillo de cabeza hexagonal de 7 mm que retiró previamente y (1) tornillo Phillips de cabeza de cono achatado suministrados. (Figura D)

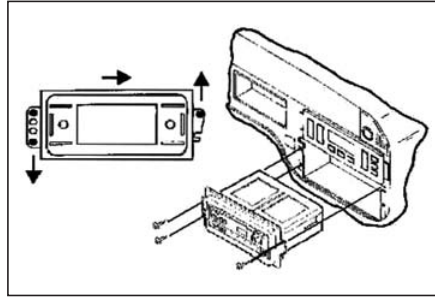
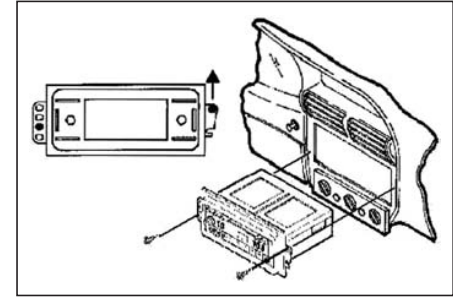
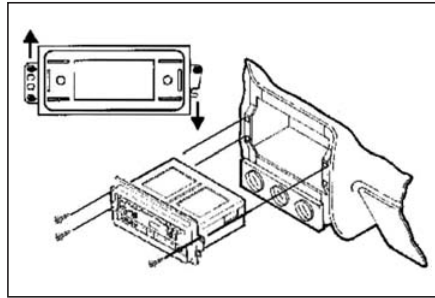
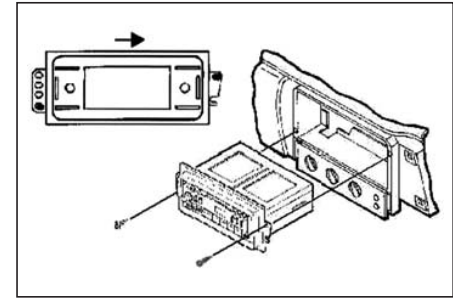
*(Figura A)**(Figura C)**(Figura B)**(Figura D)*



Instrucciones de instalación para 99-3320



REV 12/2/2014 INST99-3320



EL CONOCIMIENTO ES PODER
Mejore sus habilidades de instalación y fabricación inscribiéndose en la escuela de dispositivos electrónicos móviles más reconocida y respetada de nuestra industria. Regístrese en www.installerinstitute.com o llame al 800-354-6782 para obtener más información y avance hacia un futuro mejor.



Metra recomienda técnicos con certificación del Programa de Certificación en Electrónica Móvil (Mobile Electronics Certification Program, MECP).