

KIT COMPONENTS

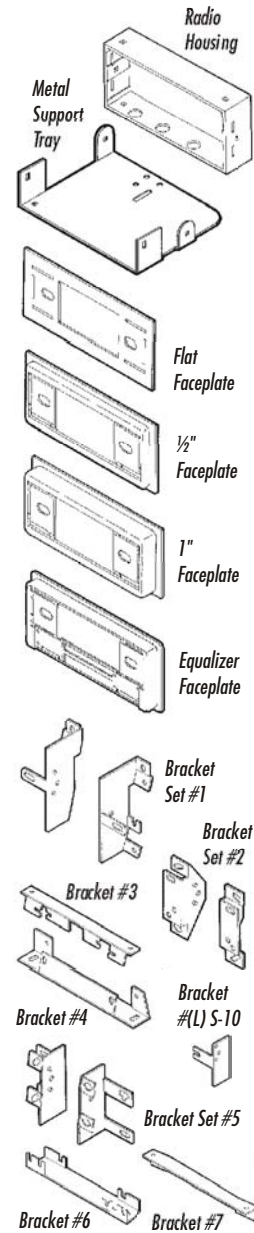

99-4512

INSTALLATION INSTRUCTIONS

APPLICATIONS

**GENERAL MOTORS 1982-96
VEHICLES EQUIPPED WITH J-2000 PANEL-STYLE
FACTORY HEAD UNIT PROVISIONS
(SEE INSIDE FOR SPECIFIC APPLICATIONS)**



TOOLS REQUIRED



Phillips screwdriver

☎ 1-800-221-0932 🌐 www.metraonline.com
© COPYRIGHT 2001 METRA ELECTRONICS CORPORATION

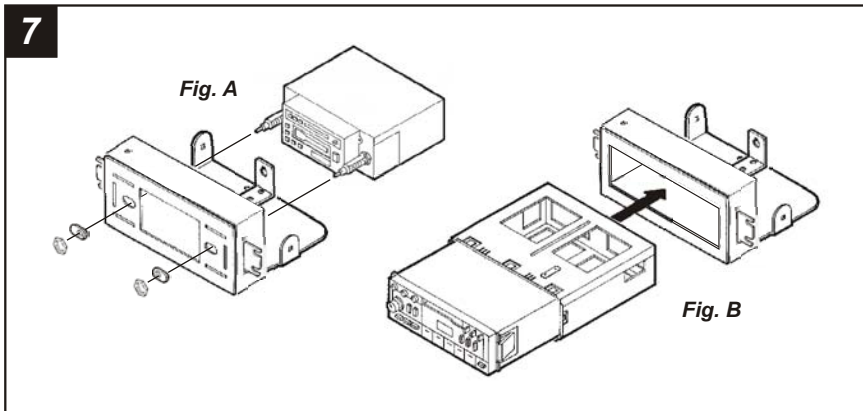

2-SHAFT HEAD UNITS: Slide the aftermarket head unit into the kit and secure with shaft nuts. Be sure the **Rear Support Bullet** on the unit engages the **Rear Support Bracket** on the **Metal Support Tray**. (see Fig. A)

DIN HEAD UNITS: Cut and remove the shaft supports from the **Faceplate**. Slide the DIN cage into the kit and secure by bending the metal locking tabs down. Slide the aftermarket head unit into the cage until secure. Be sure the **Rear Support Bullet** on the unit engages the **Rear Support Bracket** on the **Metal Support Tray**. (see Fig. B)

(If an equalizer will be included, slide the unit into the back of the **Radio Housing** and secure. If an equalizer will NOT be included, snap the **Equalizer Dummy Plate** into the opening).

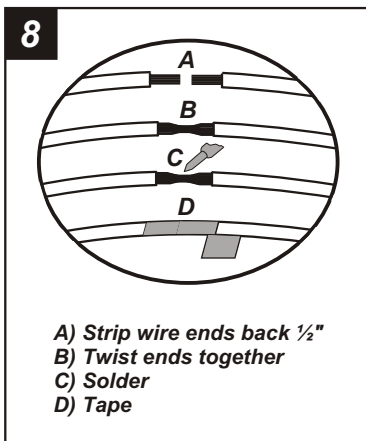

Locate the factory wiring harness in the dash. Metra recommends using the proper mating adaptor and making connections as shown. (Isolate and individually tape off the ends of any unused wires to prevent electrical short circuit).

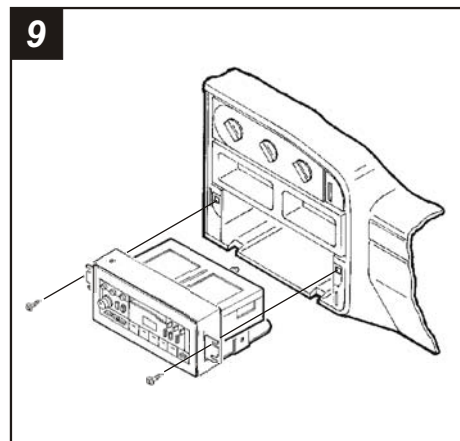

Re-connect the battery terminal and test the unit for proper operation. Mount the head unit/kit assembly to the sub-dash with those screws previously removed.

CHEVROLET Astro / GMC Safari 1985-89

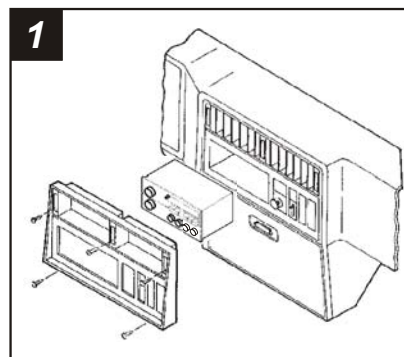

Disconnect the negative battery terminal to prevent an accidental short circuit. Remove (3) Phillips screws from the top portion of the dash trim bezel. Open the glove box and remove (2) 10mm bolts from the lower edge of the trim bezel. Pull the console trim forward and remove (2) 7mm bolts exposed. Gently unclip and remove the trim bezel. Remove (2) 7mm screws from the factory head unit and disconnect the wiring.

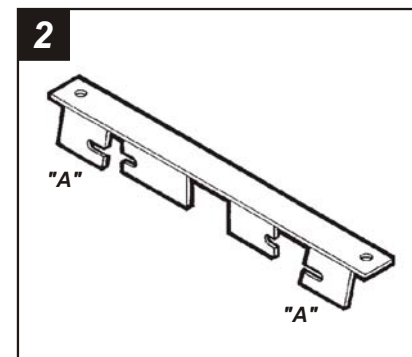

Cut and remove all mounting tabs on **Bracket #3** EXCEPT tabs "A". The mounting tabs can be identified by the stamped letter on the back of each tab. Skip to the *Installation Instructions for ALL VEHICLES on Page #11*.

CHEVROLET Beretta / Corsica 1991-96

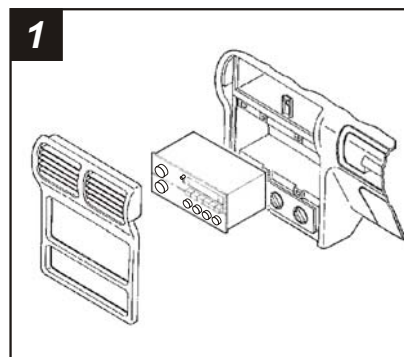

Disconnect the negative battery terminal to prevent an accidental short circuit. Using a panel removal tool, pry outward on the dash trim bezel and remove. Remove (2) screws securing the factory head unit and disconnect the wiring.

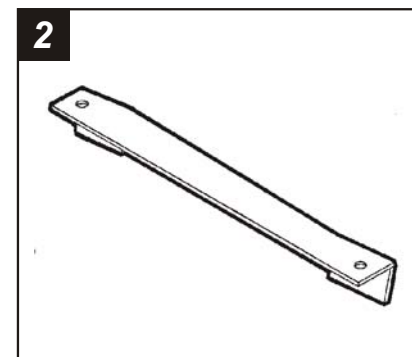

Locate **Bracket #7**. (No cutting is required). Skip to the *Installation Instructions for ALL VEHICLES on Page #11*.

CHEVROLET Camaro / PONTIAC Firebird 1982-84

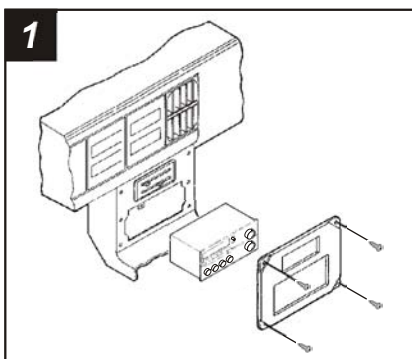

Disconnect the negative battery terminal to prevent an accidental short circuit. Remove (4) star-drive screws from the dash trim bezel and remove the bezel. Remove (4) screws securing the factory head unit and disconnect the wiring.

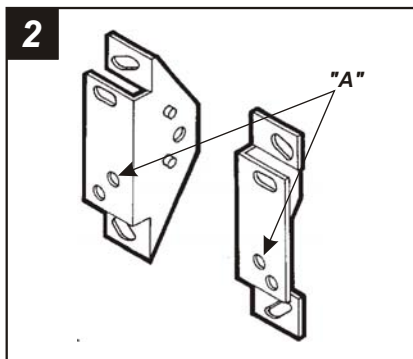

Cut and remove all mounting tabs on **Bracket Set #2** EXCEPT those tabs with holes "A". The mounting tabs can be identified by the stamped letter on the back of each tab. Skip to the *Installation Instructions for ALL VEHICLES* on Page #11.

CHEVROLET Camaro / PONTIAC Firebird 1985-92

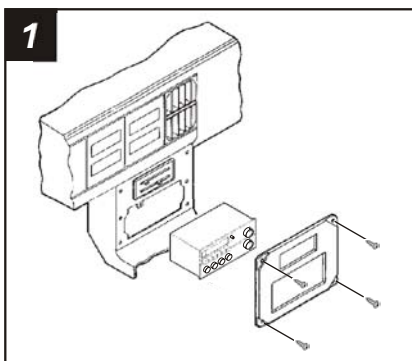

Disconnect the negative battery terminal to prevent an accidental short circuit. Remove (4) star-drive screws from the dash trim bezel and remove the bezel. Remove (4) screws securing the factory head unit and disconnect the wiring.

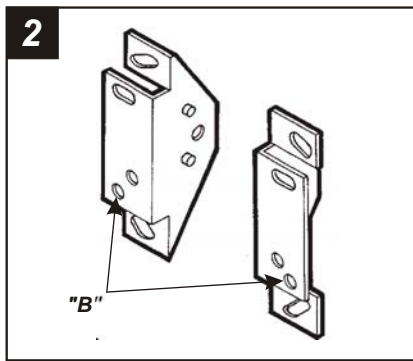

Cut and remove all mounting tabs on **Bracket Set #2** EXCEPT those tabs with holes "B". The mounting tabs can be identified by the stamped letter on the back of each tab. Skip to the *Installation Instructions for ALL VEHICLES* on Page #11.

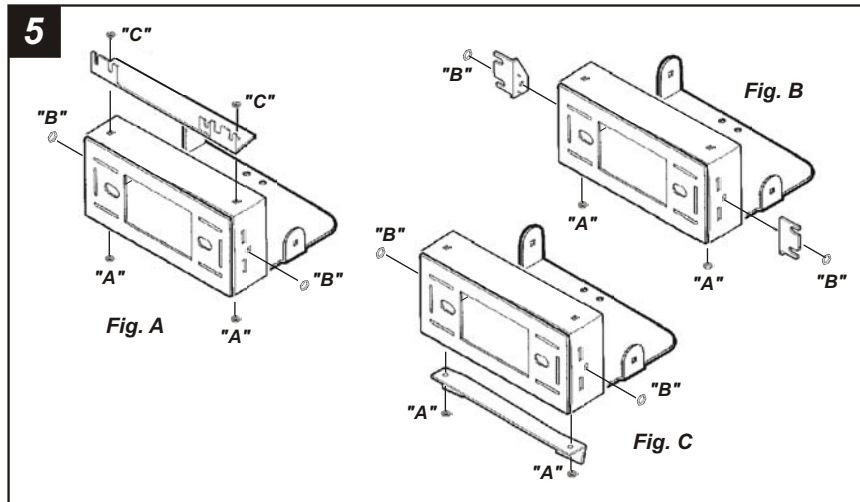

TOP MOUNTING BRACKETS: Slide the **Radio Housing** onto the **Metal Support Tray** and mount with (2) **Carriage Bolts** and (2) **Keys Nuts** ("A"). Mount the **Equalizer Brackets** to the Radio Housing with (2) Carriage Bolts and (2) Keys Nuts ("B"). Mount the factory bracket to the top of the Housing with (2) Carriage Bolts and (2) Keys Nuts ("C"). (see Fig. A)

SIDE MOUNTING BRACKETS: Slide the **Radio Housing** onto the **Metal Support Tray** and mount with (2) **Carriage Bolts** and (2) **Keys Nuts** ("A"). Mount the **Equalizer Brackets** to the Housing assembly (through the side holes) with (2) Carriage Bolts and (2) Keys Nuts ("B"). (see Fig. B)

BOTTOM MOUNTING BRACKETS: Slide the **Radio Housing** onto the **Metal Support Tray** and mount the factory bracket to the Housing (through the holes in the Tray) with (2) **Carriage Bolts** and (2) **Keys Nuts** ("A"). Mount the Equalizer Brackets to the Housing with (2) Carriage Bolts and (2) Keys Nuts ("B"). (see Fig. C)

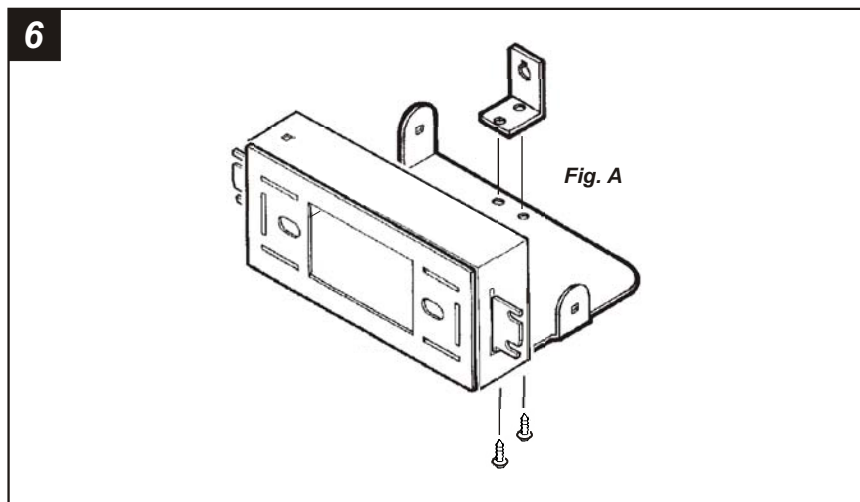

Mount the **Rear Support Bracket** to the **Metal Support Tray** with (2) **Hex-head Screws** supplied. The mounting location may vary depending on the depth of the installation. (See Fig A). Screw the **Rear Support Bullet** onto the back of the aftermarket head unit.

SATURN (all models) 1991-94

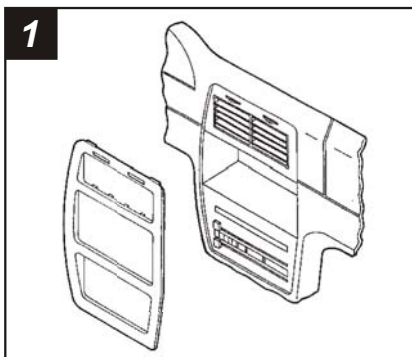

1 Disconnect the negative battery terminal to prevent an accidental short circuit. Gently unclip the dash trim bezel. Remove (2) screws from the factory head unit and disconnect the wiring.

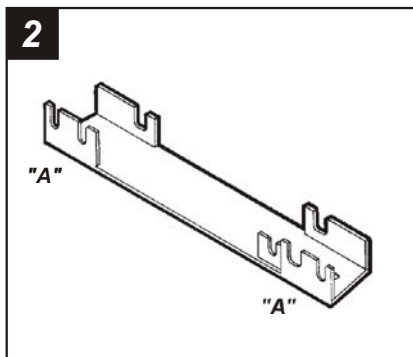

2 Cut and remove all mounting tabs on **Bracket #6** EXCEPT tabs "A". The mounting tabs can be identified by the stamped letter on the back of each tab. Skip to the *Installation Instructions for ALL VEHICLES* on Page #11.

ALL VEHICLES

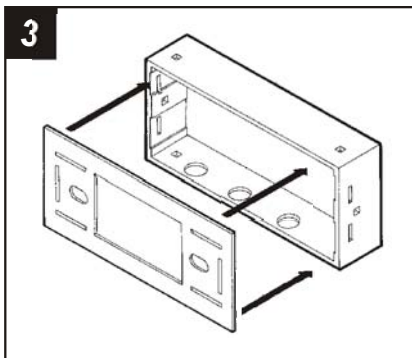

3 Choose the desired **Faceplate** and snap it onto the front of the **Radio Housing**.

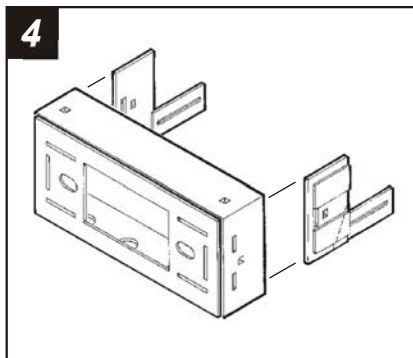

4 Slide the Equalizer Brackets into the slots along the inner walls of the Radio Housing.

CHEVROLET Caprice 1991-93 BUICK Roadmaster 1991-94

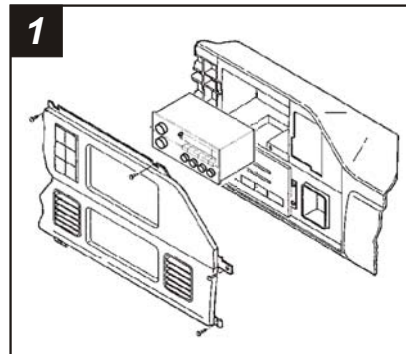

1 Disconnect the negative battery terminal to prevent an accidental short circuit. Remove (2) screws from the driver's side service panel and unclip the panel. Pry off the trim piece located above the glove box and remove (1) screw. Remove (3) screws from the top edge of the dash trim bezel. Remove (1) screw from the lower-left corner of the glove box and (1) screw from the parking brake release. Remove the dash trim bezel.

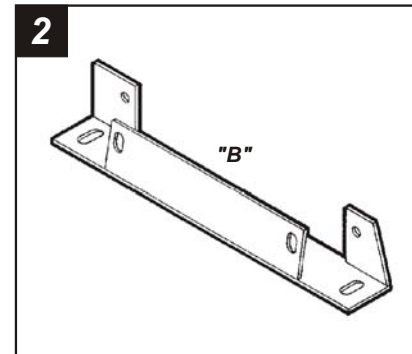

2 Cut and remove all mounting tabs on **Bracket #4** EXCEPT tabs "B". The mounting tabs can be identified by the stamped letter on the back of each tab. Skip to the *Installation Instructions for ALL VEHICLES* on Page #11.

CHEVROLET Cavalier 1982-90 / Cadillac Cimarron 1982-88 PONTIAC Sunbird J-2000 1982-88

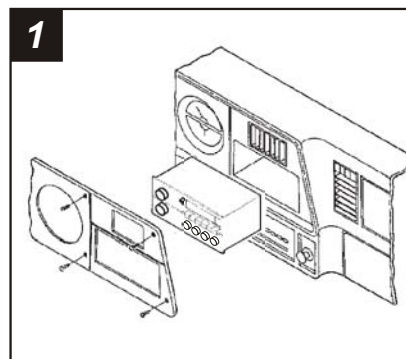

1 Disconnect the negative battery terminal to prevent an accidental short circuit. Remove (6) star-drive screws from the dash trim bezel and remove the bezel. Remove (2) screws from the factory head unit and disconnect the wiring.

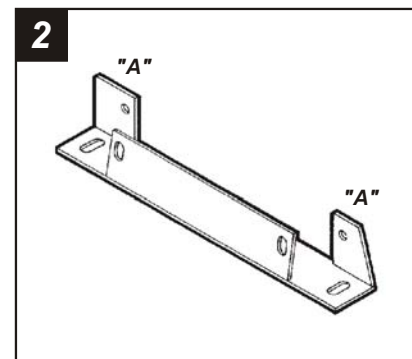

2 Cut and remove all mounting tabs on **Bracket #4** EXCEPT tabs "A". The mounting tabs can be identified by the stamped letter on the back of each tab. Skip to the *Installation Instructions for ALL VEHICLES* on Page #11.

CHEVROLET Cavalier 1991-94

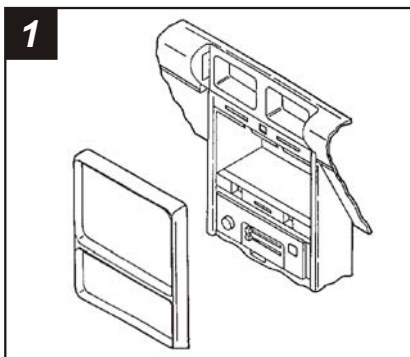

1 Disconnect the negative battery terminal to prevent an accidental short circuit. Using a panel removal tool, carefully pry out on the dash trim bezel and remove. Remove (2) screws securing the factory head unit and disconnect the wiring.

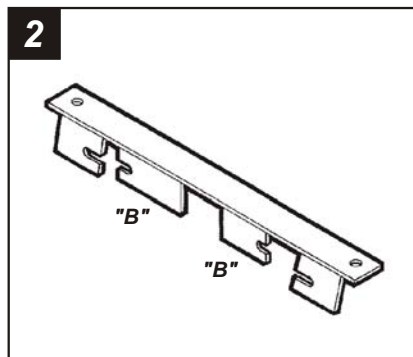

2 Cut and remove all mounting tabs on **Bracket Set #3** EXCEPT tabs "B". The mounting tabs can be identified by the stamped letter on the back of each tab. Skip to the *Installation Instructions for ALL VEHICLES* on Page #11.

PONTIAC 6000 1982-91

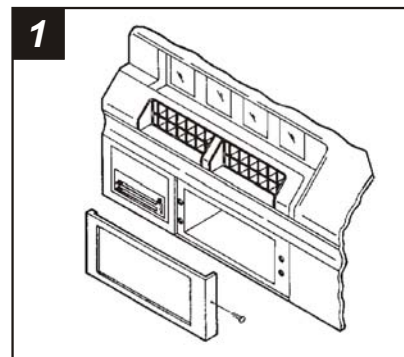

1 Disconnect the negative battery terminal to prevent an accidental short circuit. Open the glove box and remove (1) screw from the side of the radio trim bezel. Gently remove the bezel from the dash and the dummy plate from the bezel.

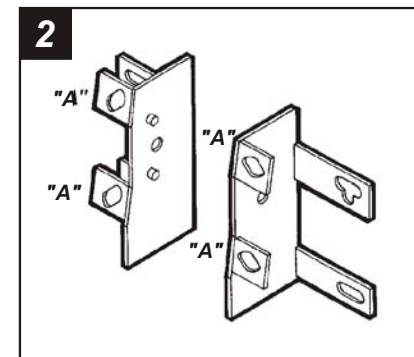

2 Cut and remove all mounting tabs on **Bracket #5** EXCEPT tabs "A". The mounting tabs can be identified by the stamped letter on the back of each tab. Skip to the *Installation Instructions for ALL VEHICLES* on Page #11.

CHEVROLET El Camino / Monte Carlo 1985-88

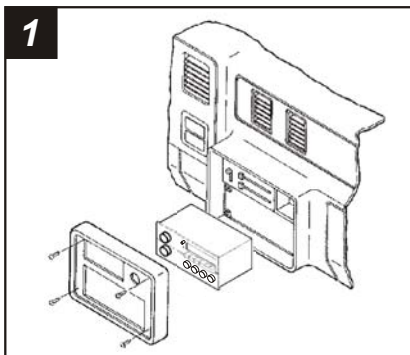

1 Disconnect the negative battery terminal to prevent an accidental short circuit. Remove (4) screws from the dash trim bezel. Remove the bezel and disconnect the cigarette lighter wiring.

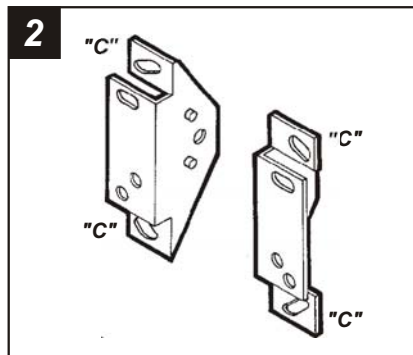

2 Cut and remove all mounting tabs on **Bracket Set #2** EXCEPT tabs "C". The mounting tabs can be identified by the stamped letter on the back of each tab. Skip to the *Installation Instructions for ALL VEHICLES* on Page #11.

PONTIAC Grand Prix 1990-93

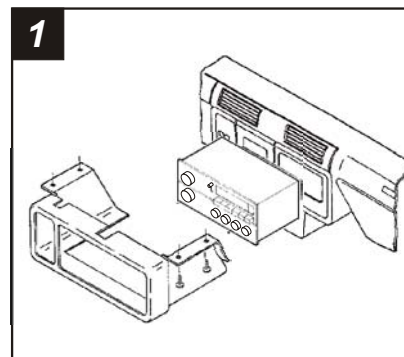

1 Disconnect the negative battery terminal to prevent an accidental short circuit. Remove (1) 9/32" hex-head screw from the computer diagnostic plug and twist to access (1) 9/32" screw on the trim panel. Remove (3) 9/32" screws from the bottom edge of the panel and remove. Open the glove box and remove (4) 9/32" screws from the dash trim bezel.

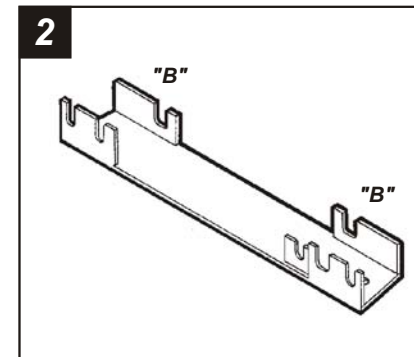

2 Cut and remove all mounting tabs on **Bracket #6** EXCEPT tabs "B". The mounting tabs can be identified by the stamped letter on the back of each tab. Skip to the *Installation Instructions for ALL VEHICLES* on Page #11.

CHEVROLET Van (full size) 1988-95 GMC Van (full size) 1988-95

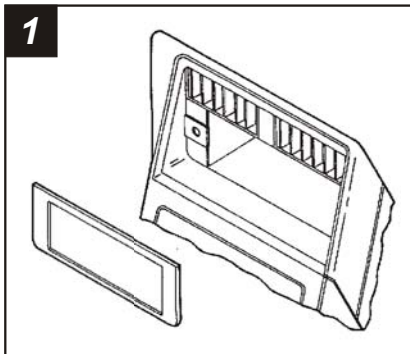

1
Disconnect the negative battery terminal to prevent an accidental short circuit. Carefully unsnap the radio trim bezel and remove. Remove (2) screws securing the factory head unit and disconnect the wiring.

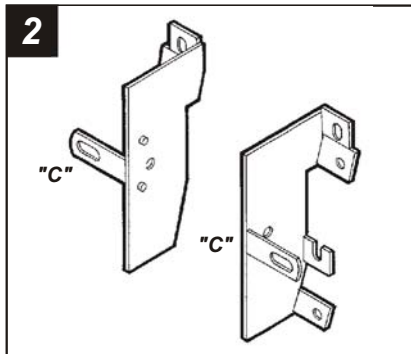

2
Cut and remove all mounting tabs on **Bracket Set #1** EXCEPT tabs "C". The mounting tabs can be identified by the stamped letter on the back of each tab. Skip to the Installation Instructions for ALL VEHICLES on Page #11.

CHEVROLET Lumina 1990-94

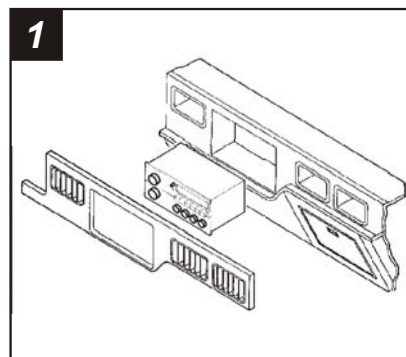

1
Disconnect the negative battery terminal to prevent an accidental short circuit. Remove (2) screws from the lower steering column panel. Pull the panel down to access the bottom portion of the radio trim bezel. Pull the top and bottom edges of the bezel forward and remove.

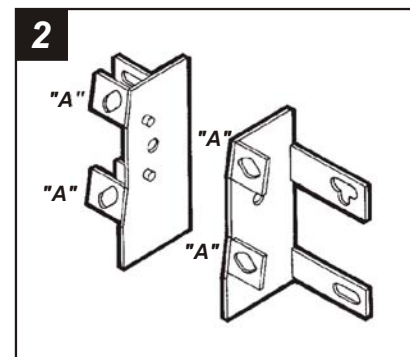

2
Cut and remove all mounting tabs on **Bracket Set #5** EXCEPT tabs "A". The mounting tabs can be identified by the stamped letter on the back of each tab. Skip to the Installation Instructions for ALL VEHICLES on Page #11.

OLDSMOBILE Omega 1983-84

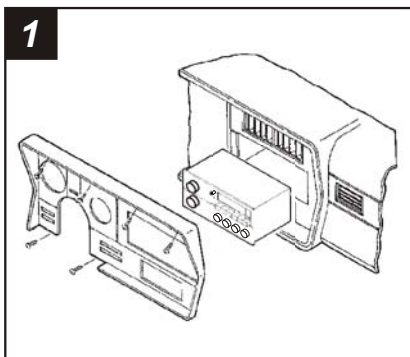

1
Disconnect the negative battery terminal to prevent an accidental short circuit. Remove (4) hex-head washer screws from the steering column trim panel, pull down on the rear edge of the panel and remove. Remove (4) Phillips screws from the top edge of the dash trim bezel. Remove (2) hex-head washer screws from the bottom of the dash trim bezel and remove the bezel.

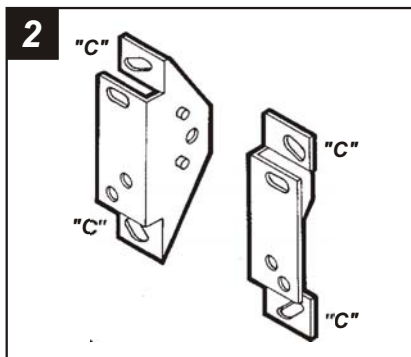

2
Cut and remove all mounting tabs on **Bracket Set #2** EXCEPT tabs "C". The mounting tabs can be identified by the stamped letter on the back of each tab. Skip to the Installation Instructions for ALL VEHICLES on Page #11.

CHEVROLET Lumina APV / OLDSMOBILE Silhouette PONTIAC TransSport 1990-95

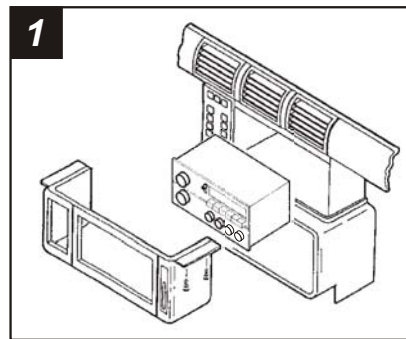

1
Disconnect the negative battery terminal to prevent an accidental short circuit. Remove (2) screws securing the lower steering column panel and remove. Remove (2) screws exposed on the left tab of the radio trim bezel. Open the glove box and remove (2) screws exposed on the right tabs of the radio trim bezel.

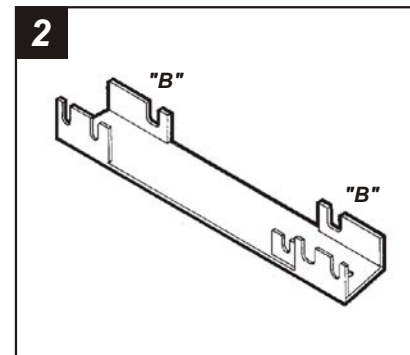

2
Cut and remove all mounting tabs on **Bracket Set #6** EXCEPT tabs "B". The mounting tabs can be identified by the stamped letter on the back of each tab. Skip to the Installation Instructions for ALL VEHICLES on Page #11.

**CHEVROLET Lumina APV / OLDSMOBILE Silhouette
PONTIAC TransSport 1996**

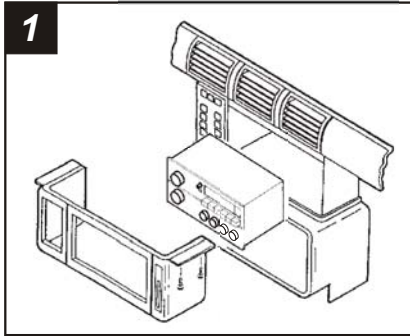

1 Disconnect the negative battery terminal to prevent an accidental short circuit. Remove (1) Phillips screw from each side of the center console. Open the glove box and remove (2) Phillips screws exposed. Remove (2) 7mm hex-head screws and (1) pop-clip from the lower steering column panel, and (2) Phillips screws exposed near the climate controls. Remove (1) 7mm hex-head screw under the glove box. Pull out on the center console and remove.

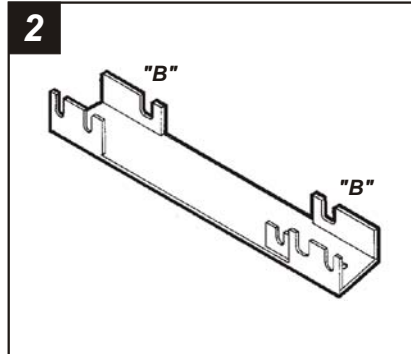

2 Cut and remove all mounting tabs on **Bracket Set #6** EXCEPT tabs "B". The mounting tabs can be identified by the stamped letter on the back of each tab. Skip to the *Installation Instructions for ALL VEHICLES* on Page #11.

**CHEVROLET S10 Pickup 1982-85 / S10 Blazer 1982-85
GMC S15 Pickup 1982-85 / S15 Jimmy 1982-85**

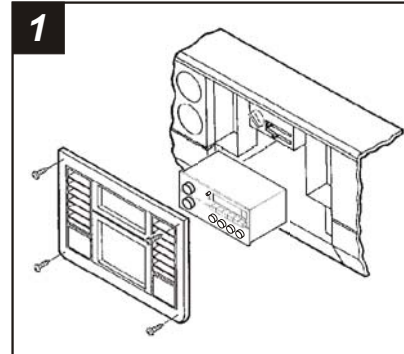

1 Disconnect the negative battery terminal to prevent an accidental short circuit. Remove (4) star-drive screws from the corners of the dash trim bezel. Remove (1) star-drive screw from the lower-right corner of the instrument cluster panel and remove the dash trim bezel.

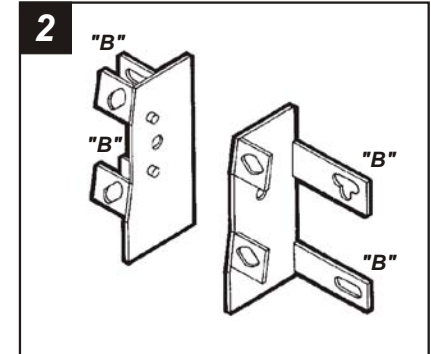

2 Cut and remove all mounting tabs on **Bracket Set #5** EXCEPT tabs "B". The mounting tabs can be identified by the stamped letter on the back of each tab. Skip to the *Installation Instructions for ALL VEHICLES* on Page #11.

CHEVROLET Nova 1985-88

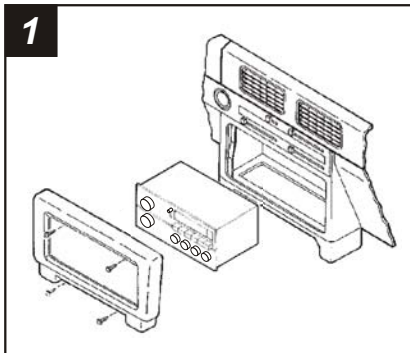

1 Disconnect the negative battery terminal to prevent an accidental short circuit. Remove the ashtray and (2) screws from the ashtray bracket. Remove (2) screws above the radio opening and remove the radio trim bezel.

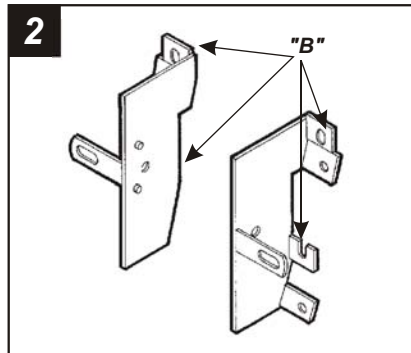

2 Cut and remove all mounting tabs on **Bracket Set #1** EXCEPT tabs "B". The mounting tabs can be identified by the stamped letter on the back of each tab. Skip to the *Installation Instructions for ALL VEHICLES* on Page #11.

**CHEVROLET S10 Pickup 1986-93 / S10 Blazer 1986-94
GMC S15 Pickup 1986-93 / S15 Jimmy 1986-94
OLDSMOBILE Bravada 1991-94**

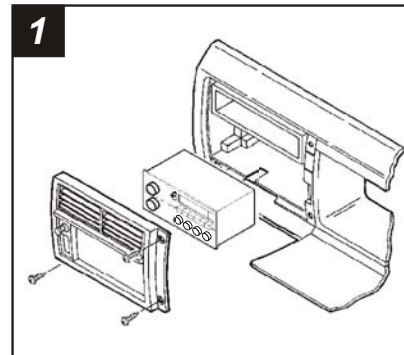

1 Disconnect the negative battery terminal to prevent an accidental short circuit. Remove the ashtray and (1) screw inside the ashtray cavity. Open the glove box and remove (2) screws exposed on the edge of the dash trim bezel.

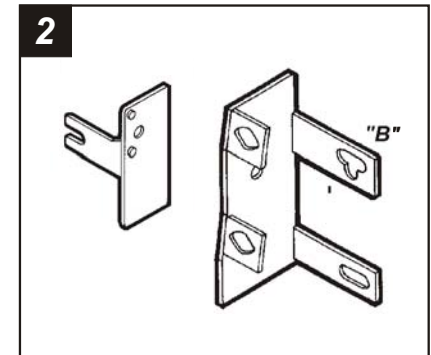

2 Locate **Bracket # (L) S-10** and the right Bracket from **Bracket Set #5**. Cut and remove all mounting tabs on the right Bracket EXCEPT top tab "B". (No cutting is required on Bracket # (L) S-10). The mounting tabs can be identified by the stamped letter on the back of each tab. Skip to the *Installation Instructions for ALL VEHICLES* on Page #11.