



## INSTALLATION INSTRUCTIONS FOR PART 99-5819

### APPLICATIONS

# Ford F-150 2009-up *(only XL models without plus package)* 99-5819

### KIT FEATURES

- DIN radio provision with pocket
- ISO DIN radio provision with pocket



### KIT COMPONENTS

- A) Radio housing • B) Radio housing brackets • C) ISO Brackets • D) Trim plate

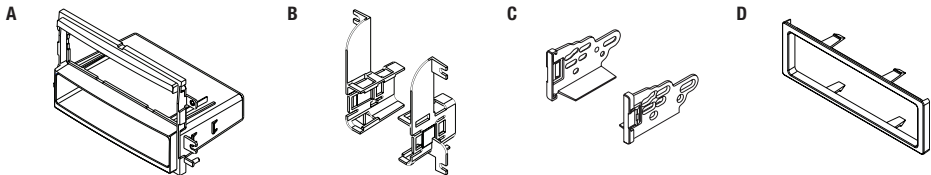

### WIRING & ANTENNA CONNECTIONS *(sold separately)*

Wiring Harness: • 70-5520 - Ford 2003-up

Antenna Adapter: • 40-CR10 - Chrysler 2002-up

### TOOLS REQUIRED

- Cutting tool • Phillips screwdriver • Socket wrench

## Table of Contents

### Dash Disassembly

- Ford F-150 2009-up  
*(only XL models without plus package)*..... 2

### Kit Assembly

- DIN radio provision with pocket..... 3
- ISO DIN radio provision with pocket..... 4

**CAUTION:** Metra recommends disconnecting the negative battery terminal before beginning any installation. All accessories, switches, and especially air bag indicator lights must be plugged in before reconnecting the battery or cycling the ignition.

**NOTE:** Refer to the instructions included with the aftermarket radio.

## Ford F-150 2009-up (only XL models without plus package)

1. Unclip and remove the switch panel to the right of the cigarette lighter then remove the (1) 9/32" screw exposed. (Figure A)
2. Remove the rubber pad at the top of the radio trim panel then remove the (2) 9/32" screws exposed. (Figure B)

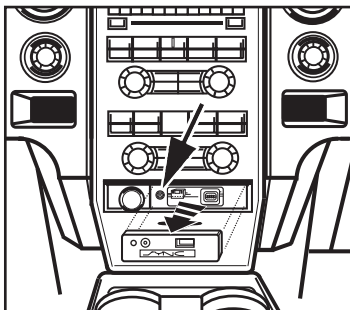

(Figure A)

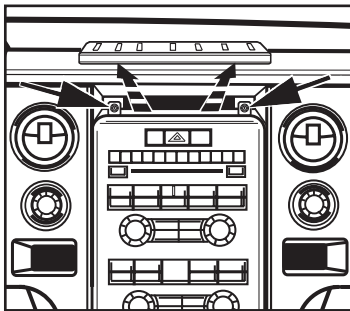

(Figure B)

3. Unclip and pull the side panels containing the A/C vents away from the radio trim panel. (Figure C)

**Note:** It is not necessary to remove the panels completely.

4. Unclip and remove the radio trim panel. (Figure D)
5. Remove (4) 9/32" screws to remove the factory radio.

Continue to kit assembly

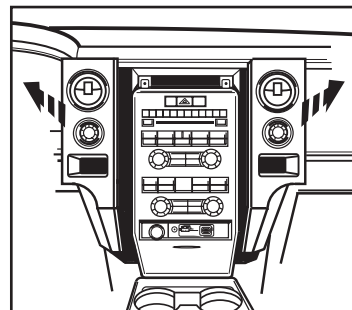

(Figure C)

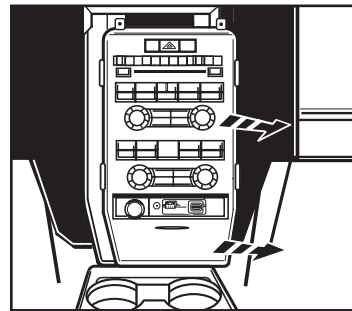

(Figure D)

## DIN radio provision with pocket

1. Cut and remove the top (2) mounting holes off of the radio housing. (Figure A)

**Note:** The notch in the housing should be on top.

2. Slide the included brackets onto the sides of the radio housings pocket from the back of the housing forward. (Figure B)

3. Slide the DIN cage into the Radio Housing and secure by bending the metal locking tabs down. (Figure C)

4. Slide the aftermarket radio into the cage and secure. (Figure D)

5. Locate the factory wiring harness in the dash. Metra recommends using the proper mating adapter from Metra or AXCESS. Re-connect the negative battery terminal and test the unit for proper operation.

7. Reassemble dash in reverse order of disassembly.

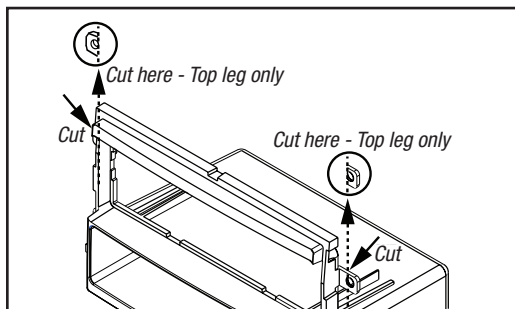

(Figure A)

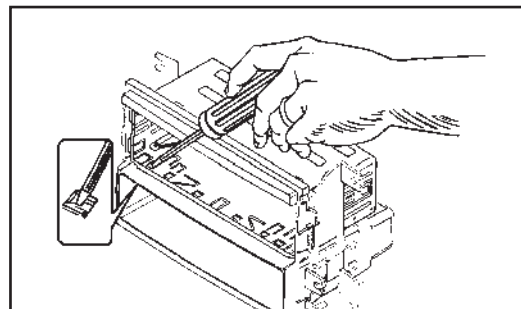

(Figure C)

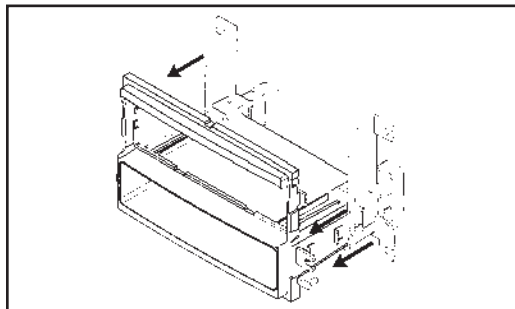

(Figure B)

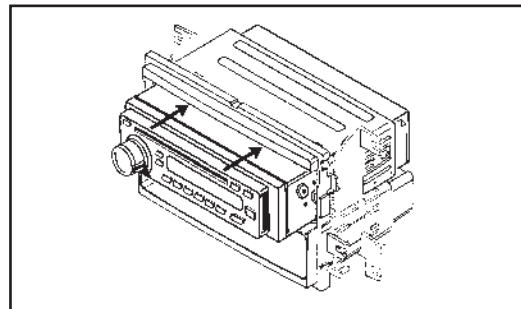

(Figure D)



## INSTALLATION INSTRUCTIONS FOR PART 99-5819



### ISO DIN radio provision with pocket

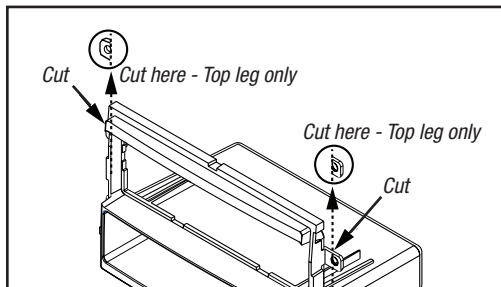

(Figure A)

1. Cut and remove the top (2) mounting holes off of the radio housing. (Figure A)
2. Slide the included brackets onto the sides of the radio housings pocket from the back of the housing forward. (Figure B)
3. Mount the ISO brackets to the radio with the screws supplied with the radio. (Figure C)
4. Slide the radio into the radio opening until the side clips engage. (Figure D)
5. Snap the trim plate into the radio housing. (Figure D)
6. Locate the factory wiring

**Note:** The notch in the housing should be on top.

harness in the dash. Metra recommends using the proper mating adapter from Metra or AXCESS. Re-connect the negative battery terminal and test the unit for proper operation.

7. Reassemble dash in reverse order of disassembly.

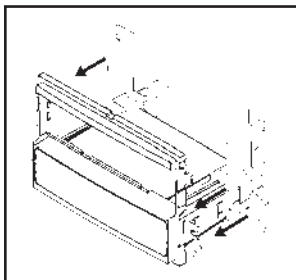

(Figure B)

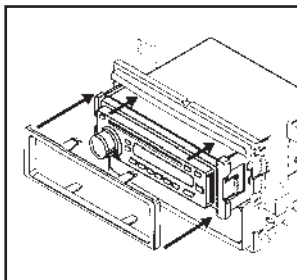

(Figure D)

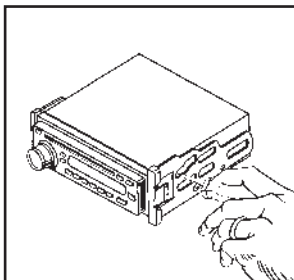

(Figure C)



#### KNOWLEDGE IS POWER

Enhance your installation and fabrication skills by enrolling in the most recognized and respected mobile electronics school in our industry. Log onto [www.installerinstitute.com](http://www.installerinstitute.com) or call 800-354-6782 for more information and take steps toward a better tomorrow.



Metra recommends MECP certified technicians