



INSTALLATION INSTRUCTIONS FOR PART 99-5825

APPLICATIONS

Ford Fiesta 2011-up

99-58255
99-5825B

KIT FEATURES

- ISO DIN Head unit provision
- Driver information circuits and buttons
- Painted Silver or Matte Black to match factory finish

KIT COMPONENTS

- A) Radio Housing
- B) Radio ISO Brackets
- C) (6) #8 x 3/8" Phillips truss head screws

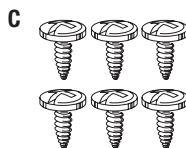
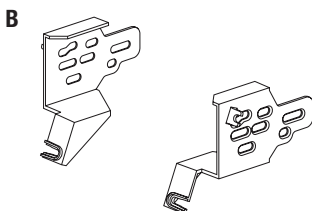
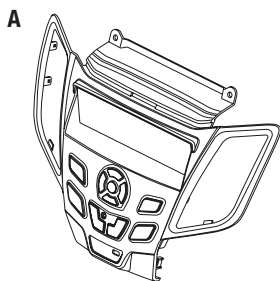

WIRING & ANTENNA CONNECTIONS (Sold Separately)

Wire harness:

- XSVI-5524-NAV Ford interface 2011-up

Antenna adapter:

- 40-EU10 multi-app adapter

TOOLS REQUIRED

Panel Removal Tool • Phillips Screwdriver • Socket Wrench • Cutting Tool

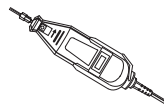
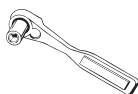
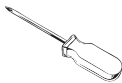
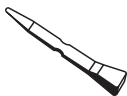

METRA. THE WORLD'S BEST KITS.™



1-800-221-0932



metraonline.com

© COPYRIGHT 2004-2011 METRA ELECTRONICS CORPORATION



99-5825

Table of Contents

Dash Disassembly

– Ford Fiesta 2011-up.....3-4

Kit Assembly

– Ford Fiesta 2011-up, ISO DIN head unit provisions 5

NOTE: This kit comes pre-programmed for vehicles equipped **with SYNC**. It will not operate properly in vehicles equipped **without SYNC** unless it is programmed.

Programming for vehicles without SYNC:

1. Turn on the ignition.
2. Press and hold the kit's menu button for ten seconds.
3. Release the menu button and test the kit's buttons for proper operation.

Caution

Metra recommends disconnecting the negative battery terminal before beginning any installation. All accessories, switches, and especially air bag indicator lights must be plugged in before reconnecting the battery or cycling the ignition.

***NOTE: Refer Also to the instructions included with the aftermarket radio.**



KNOWLEDGE IS POWER

Enhance your installation and fabrication skills by enrolling in the most recognized and respected mobile electronics school in our industry. Log onto www.installerinstitute.com or call 800-354-6782 for more information and take steps toward a better tomorrow.



Metra recommends MECP certified technicians

Dash Disassembly

1. Unsnap and remove the panel over the display at the top of the dash. (Figure A)
2. Remove two 7 mm hex screws from the top of the radio panel. (Figure B)
3. Unclip and remove the radio trim panel including the vents. (Figure C)

Continued on next page

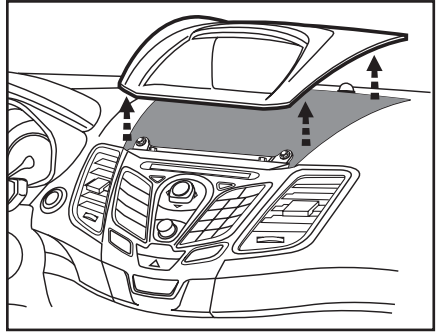

(Figure A)

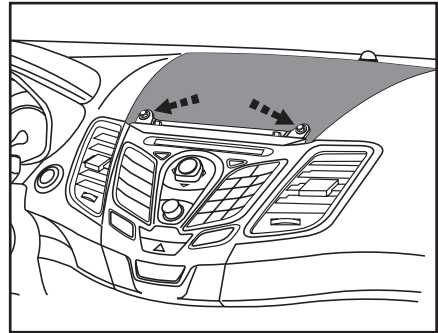

(Figure B)

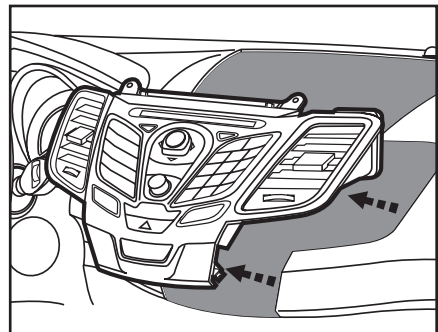

(Figure C)

Dash Disassembly

4. Remove two 7 mm hex holding radio and radio chassis together (from top of panel). (Figure A)
5. Remove two T-20 Torx and unclip the two vents from the factory radio panel. (Figure B)
6. Remove two T-20 Torx from passenger airbag light and remove it. (Figure B)
7. A small cut is required in the sub dash for clearance. (Figure C)

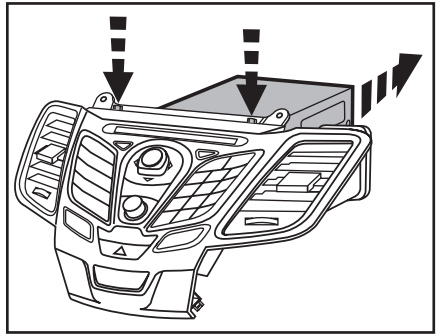

(Figure A)

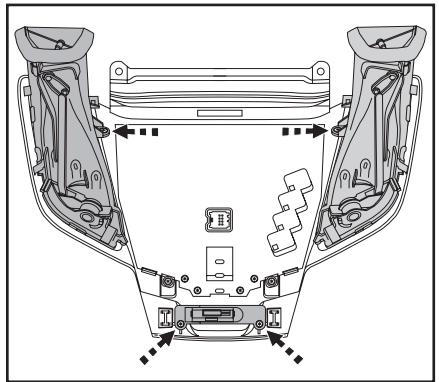

(Figure B)

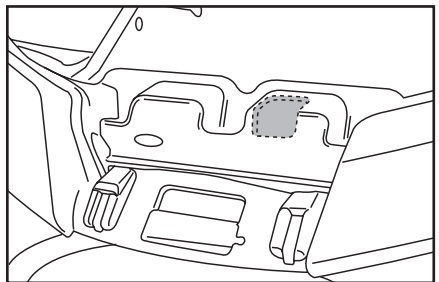

(Figure C)



Kit Assembly 99-5825

ISO DIN head unit provisions

1. Snap the factory vents into the radio panel. (Figure A)
2. Mount the ISO brackets to the head unit with the screws supplied with the unit. (Figure B)
3. Mount the radio bracket assembly to the radio panel using the supplied screws. (Figure C)
4. Mount the factory airbag indicator to the Radio Panel using the supplied screws. (Figure A)
5. Locate the factory wiring harness and antenna plug in the dash. Metra recommends using the proper mating adapters from Metra and/or AXCESS.
6. Reassemble dash in reverse order of disassembly.

NOTE: This kit comes pre-programmed for vehicles equipped **with SYNC**. It will not operate properly in vehicles equipped **without SYNC** unless it is programmed.

Programming for vehicles without SYNC:

1. Turn on the ignition.
2. Press and hold the kit's menu button for ten seconds.
3. Release the menu button and test the kit's buttons for proper operation.

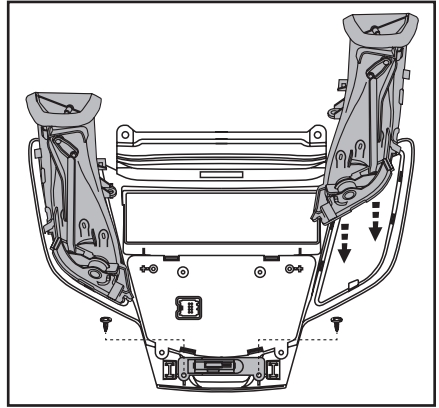

(Figure A)

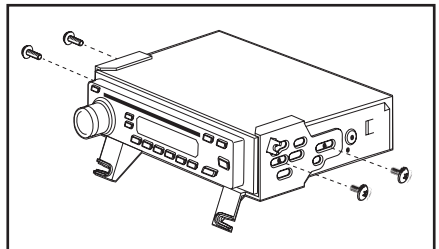

(Figure B)

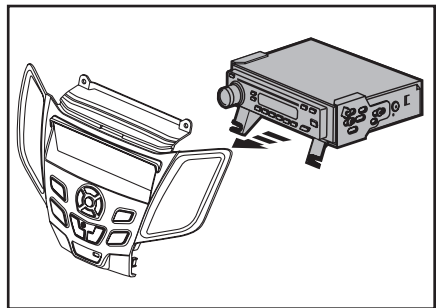

(Figure C)



INSTALLATION INSTRUCTIONS FOR PART 99-5825

REV. 7/13/11

METRA. THE WORLD'S BEST KITS.™



1-800-221-0932



metraonline.com

© COPYRIGHT 2004-2011 METRA ELECTRONICS CORPORATION