



Ford Fusion 2013-up*

*Visit metraonline.com for up-to-date vehicle specific applications.

KIT FEATURES

- ISO DIN radio provision with pocket
- ISO DDIN radio provision
- Integrated controls for info center
- Painted black

Note: Does not support amplified systems.

KIT COMPONENTS

- A) Radio trim panel with touchscreen display
- B) Radio brackets
- C) Pocket
- D) (4) #8 x 3/8" Phillips screws
- E) (4) Panel clips
- F) HVAC interface and wiring harness (not shown)

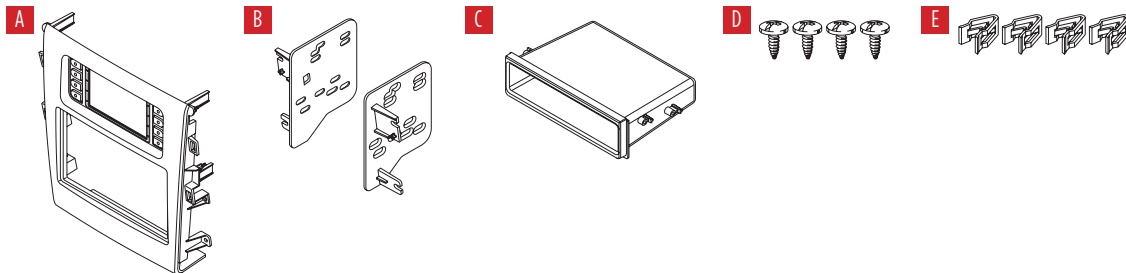

TABLE OF CONTENTS

Dash Disassembly.....	2
Kit Preparation.....	3
Kit Assembly	
–ISO DIN radio provision with pocket.....	4
–ISO DDIN radio provision.....	4
Axxess Interface Installation.....	5-14

WIRING & ANTENNA CONNECTIONS

Wiring Harness: Axxess interface and harness included

Antenna Adapter: 40-EU10 (sold separately)

TOOLS REQUIRED

- Panel removal tool
- Phillips screwdriver
- 7mm socket wrench
- Cutting tool

CAUTION! All accessories, switches, climate controls panels, and especially air bag indicator lights must be connected before cycling the ignition. Also, do not remove the factory radio with the key in the on position, or while the vehicle is running.

DASH DISASSEMBLY

For 2013-2016 models only:

1. Unclip the trim from around the shifter. (Figure A)
2. Unclip the U-shaped trim from the rear of the shifter. (Figure B) 14-16 only

For 2017-up models only:

3. Remove the left and right side panels on the center console, and then remove the (2) 7mm screws exposed. (Figure D)

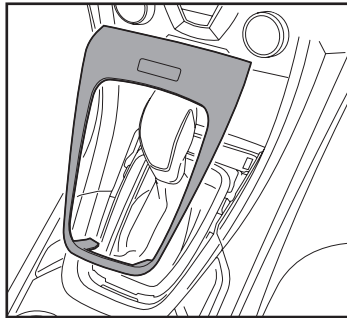

(Figure A)

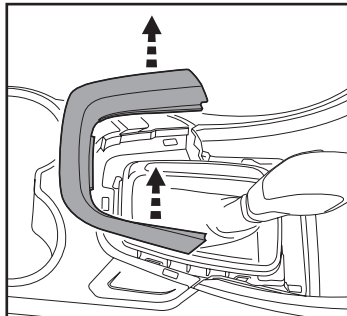

(Figure B)

All models:

4. Unclip the trim surrounding the center dash. (Figure C)
- Ensure that the vehicle is completely off before proceeding onto the following (3) steps
5. Remove the (2) 9/32" screws securing the radio/climate control panel, and then unclip, unplug, and remove.
 6. Remove the (4) 9/32" screws securing the display screen, and then unplug and remove.
 7. Remove the (2) 9/32" screws securing the radio chassis, and then unplug and remove.

Continue to Kit Preparation

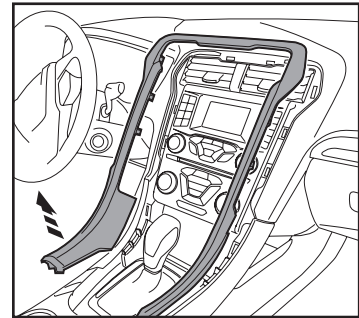

(Figure C)

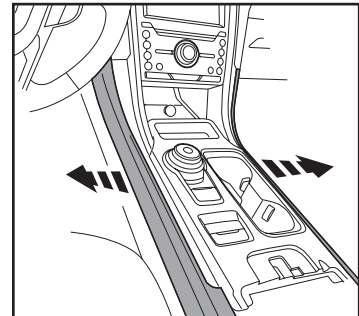

(Figure D)

KIT PREPARATION

1. Cut and remove the shaded area from the sub-dash to allow clearance for the aftermarket radio. (Figure A)
2. Attach the (4) panel clips provided to the radio trim panel. (Figure B)

Continue to Kit Assembly

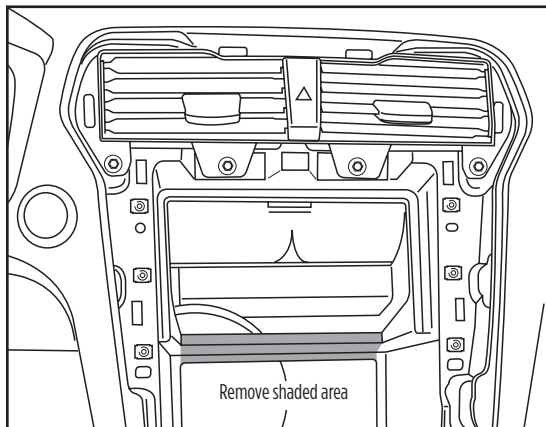

(Figure A)

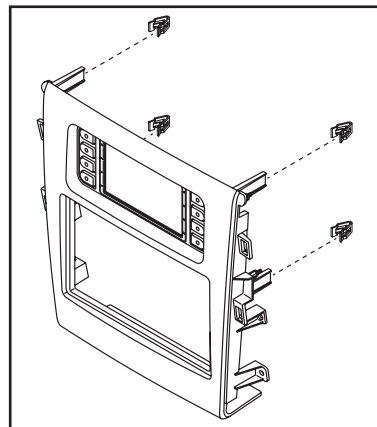

(Figure B)

KIT ASSEMBLY

ISO DIN radio provision with pocket

1. Attach the *pocket* to the *radio brackets* using the (4) #8 x 3/8" Phillips screws provided. (Figure A)
2. Remove the metal DIN sleeve and trim ring from the aftermarket radio.
3. Slide the radio into the bracket/pocket assembly, and then secure it using the screws supplied with the radio. (Figure B)

Continue to Axxess Interface Installation

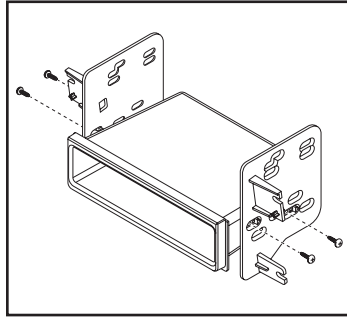

(Figure A)

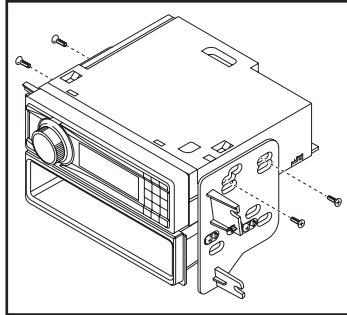

(Figure B)

ISO DDIN radio provision

1. Attach the *brackets* to the radio using the screws supplied with the radio. (Figure A)

Continue to Axxess Interface Installation

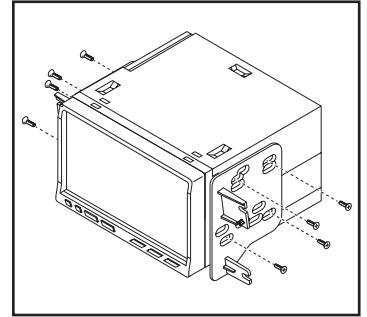

(Figure A)

AXXESS INTERFACE INSTALLATION

INTERFACE FEATURES

- Provides accessory power (12-volt 10-amp)
- Retains R.A.P. (retained accessory power)
- Provides NAV outputs (parking brake, reverse, speed sense)
- Retains audio controls on the steering wheel
- Retains SYNC® (4.2-inch display screen models only)
- Retains the factory backup camera
- Supports non-amplified systems
- Retains balance and fade
- Micro “B” USB updatable

INTERFACE COMPONENTS

- Axxess interface (built into the touchscreen display)
- 5841 harness
- HVAC interface
- HVAC interface harness
- 4-pin flat to 4-pin stacked harness
- 16-pin harness with stripped leads
- 54-pin backup camera harness
- 12-pin backup camera harness
- 4-pin harness with yellow RCA jacks
- Male DIN connector with a 6-pin harness
- Female 3.5mm connector with stripped leads

TABLE OF CONTENTS

Connections to be made	6-7
Installing the interface	8
Initializing the interface	9
Final assembly	9
Touchscreen display operation	10-11
Steering wheel control settings	12-13

TOOLS REQUIRED

- Wire cutter • Crimp tool • Solder gun • Tape
- Connectors (example: butt-connectors, bell caps, etc.)

CONNECTIONS TO BE MADE

From the 16-pin harness with stripped leads to the aftermarket radio:

- Connect the **Red** wire to the accessory wire.
- If the aftermarket radio has an illumination wire, connect the **Orange/White** wire to it.
- If the aftermarket radio has a mute wire, and the vehicle is equipped with SYNC®, connect the **Brown** wire to it. If the mute wire is not connected, the radio will turn off when SYNC® is activated.
- Connect the **Gray** wire to the right front positive speaker output.
- Connect the **Gray/Black** wire to the right front negative speaker output.
- Connect the **White** wire to the left front positive speaker output.
- Connect the **White/Black** wire to the left front negative speaker output.
- Tape off and disregard the following (5) wires, they will not be used in this application.
Blue/White, Green, Green/Black, Purple, Purple/Black

The following (3) wires are only for multimedia/navigation radios that require these wires.

- Connect the **Blue/Pink** wire to the VSS/speed sense wire.
- Connect the **Green/Purple** wire to the reverse wire.
- Connect the **Light Green** wire to the parking brake wire

From the 5841 harness to the aftermarket radio:

- Connect the **Black** wire to the ground wire.
- Connect the **Yellow** wire to the battery wire.
- Connect the **Blue** wire to the power antenna wire.
- Connect the **Green** wire to the left rear positive speaker output.
- Connect the **Green/Black** wire to the left rear negative speaker output.
- Connect the **Purple** wire to the right rear positive speaker output.
- Connect the **Purple/Black** wire to the right rear negative output.
- For models with a 4.2-inch display screen and SYNC®: Connect the **Red** and **White** RCA jacks labeled “RSE/SYNC®/SAT” to the audio AUX-IN jacks of the aftermarket radio.
- Disregard the **Red** and **White** RCA jacks labeled “FROM 3.5”, they will not be used in this application.

Continued on the next page

3.5mm jack steering wheel control retention:

- The 3.5mm jack is to be used to retain audio controls on the steering wheel control.
- For the radios listed below, connect the included *female 3.5mm connector with stripped leads*, to the male 3.5mm SWC jack from the 5834 harness. Any remaining wires tape off and disregard:

- **Eclipse:** Connect the steering wheel control wire, normally **Brown**, to the **Brown/White** wire of the connector. Then connect the remaining steering wheel control wire, normally **Brown/White**, to the **Brown** wire of the connector.

- **Metra OE:** Connect the steering wheel control Key 1 wire (**Gray**) to the **Brown** wire.

- **Kenwood or select JVC with a steering wheel control wire:** Connect the **Blue/Yellow** wire to the **Brown** wire.

Note: If your Kenwood radio auto detects as a JVC, manually set the radio type to Kenwood. See the instructions under changing radio type.

- **XITE:** Connect the steering wheel control SWC-2 wire from the radio to the **Brown** wire.

- **Parrot Asteroid Smart or Tablet:** Connect the 3.5mm jack into the AX-SWC-PARROT (sold separately), and then connect the 4-pin connector from the AX-SWC-PARROT into the radio.

Note: The radio must be updated to rev. 2.1.4 or higher software.

- **Universal “2 or 3 wire” radio:** Connect the steering wheel control wire, referred to as Key-A or SWC-1, to the **Brown** wire of the connector. Then connect the remaining steering wheel control wire, referred to as Key-B or SWC-2, to the **Brown/White** wire of the connector. If the radio comes with a third wire for ground, disregard this wire.

Note: After the interface has been programmed to the vehicle, refer to the manual provided with the radio for assigning the SWC buttons. Contact the radio manufacturer for more information

- **For all other radios:** Connect the 3.5mm jack into the port on the radio designated for an external steering wheel control interface. Refer to the manual provided with the radio if in doubt as to where the 3.5mm jack goes to.

Backup camera harness:

For models with a 4.2-inch display screen: Use the 12-pin backup camera harness.

For models with an 8-inch display screen: Use the 54-pin backup camera harness.

There are two different methods for connecting the factory backup camera.

If retaining the camera to the aftermarket radio is desired:

- Connect the **Yellow** RCA jack the backup camera input of the aftermarket radio.

If retaining the camera to the touchscreen display is desired:

- Connect the **Yellow** RCA jack, to the **Yellow** RCA jack from the 4-pin harness with yellow RCA jacks labeled “Rearview camera”.

Note: If this method is chosen, the backup camera option must be enabled in the *Configuration Settings Screen*.

4-pin harness with yellow RCA jacks:

- If retaining the factory backup camera to the touchscreen display is desired, connect the **Yellow** RCA jack labeled “Rearview camera”, to the **Yellow** RCA jack from the 12-pin or 54-pin backup camera harness.
- Disregard the **Yellow** RCA jack labeled “AUX video”, it will not be used in this application.

INSTALLING THE INTERFACE

It is highly advisable to read the following steps beforehand, to ensure a clear understanding of what is to be expected. The following steps must be done in the order that they are numbered.

With the vehicle completely off:

Touchscreen display

1. Connect the *16-pin harness with stripped leads* into port “B” in the touchscreen display.
2. Connect the *5841 harness* to the wiring harnesses in the vehicle. These harnesses are the ones removed in step 7 of dash disassembly. Then insert the *5841 harness* into port “A” in the touchscreen display. But do not install this harness until exactly before step 1 of “Initializing the Interface”. This is a timed process.
3. Connect the *4-pin harness with yellow RCA jacks* into port “C” in the touchscreen display.
4. Disregard ports “D” and “E”, they will not be used in this application.
5. Port “F” is an update port for future firmware upgrades.

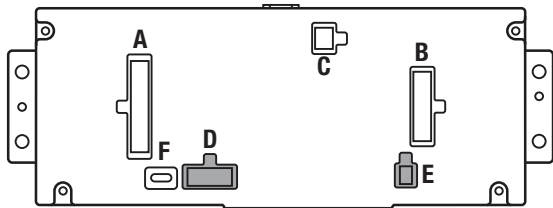

HVAC interface

6. Connect the *HVAC interface harness* into the *HVAC interface*, and then to the wiring harnesses in the vehicle. These harnesses are the ones removed in step 5 of dash disassembly.
Note: Disregard the “10-pin harness”, and the “4-pin flat to 4-pin stacked harness”, they will not be used in this application.
7. Connect the *male DIN connector with a 6-pin harness*, to the female DIN jack from the *5841 harness*. It would be best to tape or heat shrink this connector to prevent it from being disconnected.
 - a. Then connect the 6-pin harness into the *HVAC interface*.
 - b. Disregard the **Red** wire, it will not be used in this application.
8. **(a) For models with a 4.2-inch display screen:** Connect the *12-pin backup camera harness*, to the wiring harness in the vehicle. This harness is the one removed in step 6 of dash disassembly.
(b) For models with an 8-inch display screen: Connect the female connector of the *54-pin backup camera harness*, to the wiring harness in the vehicle. This connector is located behind the factory display screen, which was removed in step 6 of dash disassembly.
Note: Disregard the male connector, it will not be used in this application.
9. Locate the factory antenna connector in the dash and complete all necessary connections to the radio. Metra recommends using the proper mating adapter from Metra.

INITIALIZING THE INTERFACE

Attention! If the interface loses power for any reason, the following steps will need to be performed again.

1. Refer to step 2 of “Installing the interface”.
2. Press the push-to-start button to start the vehicle.
3. Program the kit:
 - a. Once the touchscreen display loads up, select the vehicle type; “Ford Fusion 2015-2017”.
 - b. Wait until the radio comes on, and the touchscreen display shows “SWC Configured”. This process may take up to 3 minutes.

Note: If the touchscreen display does not load up, or the radio doesn’t come on within 3 minutes, and/or the touchscreen display does not show “*SWC Configured*”, turn the vehicle off and disconnect the *5841 harnesses* from port “A” in the touchscreen display. Check all the connections, reconnect the harness into the touchscreen display, and then try again.

4. Test all functions of the installation for proper operation, before reassembling the dash.

FINAL ASSEMBLY

1. Secure the completed assembly into the dash using the factory hardware removed in step 7 of dash disassembly. Only use the upper mounting tabs.
2. Snap the *radio trim panel with touchscreen display* over the completed assembly, and then reassemble the dash in reverse order of disassembly.

TOUCHSCREEN DISPLAY OPERATION

Climate Control screen

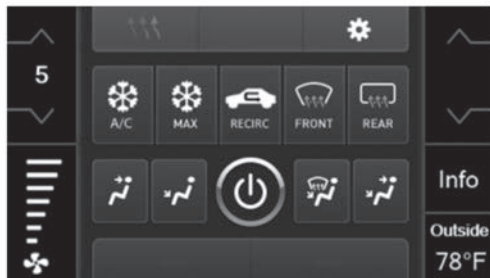

Manual climate controls



Automatic climate controls

- This is the climate control screen which will be displayed on the touchscreen display. This is considered the main screen.
- The upper left tab with (3) arrows will take you to the **Heated/Cooled*** seats screen, and the **Heated Steering*** screen.
- The upper right tab with the gear icon will take you to the **Configuration Settings** screen.
- **Auto climate models:** The climate controls will function in the same manner that they did with the factory climate controls.
- **Manual climate models:** The climate controls will function in the same manner that they did with the factory climate controls, yet via touchscreen buttons instead. The temperature control will display a numerical scale, with “LO” being the coldest, and “HI” being the hottest: LO / 1-9 / HI

***If applicable.**

Note: The “Info” button will only be shown if SYNC® is to be retained.

Continued on the next page

Configuration Settings screen

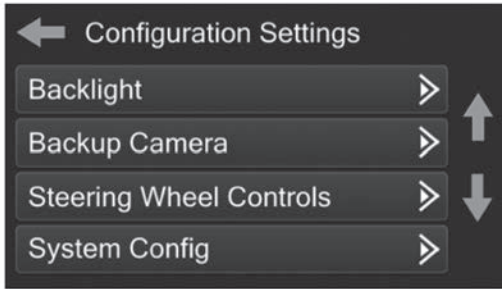

- **Backlight**
 - Four slide bars control the color of the buttons and the back-light intensity:
Red / Green / Blue / Backlight
- **Backup Camera**
 - Enable – Enables the backup camera image to the touchscreen display
 - Disable – Disables the backup camera image to the touchscreen display (default)
- **Steering Wheel Controls**
 - Remap Buttons – For remapping the steering wheel control buttons
 - Dual Assign – For dual assigning the steering wheel control buttons (long button press)
 - Select Radio – For auto detecting the radio, or changing the radio type
- **Ambient Lighting**
 - Factory colors available from Ford
- **System Configuration**
 - Firmware version

Touchscreen calibration:

- Press and hold the upper two soft buttons on the main screen for 10 seconds.
- A screen will pop up asking for you to press the target in the screen.
- After pressing the target with your finger, the calibration process will be complete, and the screen will disappear.

STEERING WHEEL CONTROL SETTINGS

Select Radio screen



- To show which brand radio is “auto detected” to the interface, press the “Autodetect” button. The radio detected will have a filled in circle. If the incorrect radio is shown, select the proper radio.
- Following is a list of radio manufacturers that the interface presently acknowledges. Others may be added at a later date. Universal “2 or 3 wire” radios can show up as any of these radio manufacturers.

Eclipse (Type 1) †	JVC	Clarion (Type 2) †	Parrot **
Kenwood ‡	Pioneer/Jensen	Metra OE	XITE
Clarion (Type 1) †	Alpine *	Eclipse (Type 2) †	Philips
Sony / Dual	Visteon	LG	JBL
	Valor		

*** Note:** If the interface shows an Alpine radio, and you do not have an Alpine radio, that means the interface does not detect a radio connected it, i.e., an open connection. Verify that the 3.5mm jack is connected to the correct steering wheel jack/wire in the radio.

**** Note:** The AX-SWC-PARROT is required (sold separately). Also, the Parrot radio must be updated to rev. 2.1.4 or higher through www.parrot.com.

† Note: If you have a Clarion radio and the steering wheel controls do not work, change the radio type to the other Clarion radio type; same for Eclipse.

‡ Note: If you have a Kenwood radio and the touchscreen display shows a JVC radio, change the radio type to Kenwood.

Continued on the next page

STEERING WHEEL CONTROL SETTINGS (CONT.)

Remap Button screen



- The interface has the ability to change the button assignment for the steering wheel control audio buttons, except Volume-Up and Volume-Down. Follow the prompts on the touchscreen display to remap the steering wheel control audio button(s) to your liking.

Note: The aftermarket radio may not have all of these commands. Please refer to the manual provided with the radio, or contact the radio manufacturer, for specific commands recognized by that particular radio.

Dual Assign screen

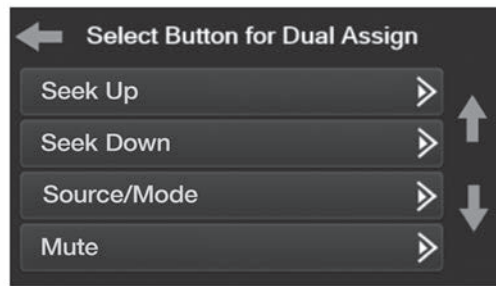

- The interface has the capability to assign two functions to a single button, except Volume-Up and Volume-Down. Follow the prompts on the touchscreen display to program the button(s) to your liking.

Note: Seek-Up and Seek-Down come programmed as Preset-Up and Preset-Down for a long button press.



99-5841B
INSTALLATION INSTRUCTIONS



IMPORTANT

If you are having difficulties with the installation of this product, please call our Tech Support line at 1-800-253-TECH. Before doing so, look over the instructions a second time, and make sure the installation was performed exactly as the instructions are stated. Please have the vehicle apart and ready to perform troubleshooting steps before calling.



KNOWLEDGE IS POWER

Enhance your installation and fabrication skills by enrolling in the most recognized and respected mobile electronics school in our industry. Log onto www.installerinstitute.com or call 800-354-6782 for more information and take steps toward a better tomorrow.



**Metra recommends MECP
certified technicians**