



Ford Mustang (with dual zone climate controls) 2015-2023

Visit MetraOnline.com for more detailed information about the product and up-to-date vehicle specific applications

KIT FEATURES

- Factory-style hard buttons with laser etched graphics to retain and control most climate functions normally lost when removing factory radio
- Easy to use rotary knobs with LCD status displays for temp and fan speed
- Retains steering wheel functionality - no need to purchase and install a separate steering wheel control interface.
- Parts included for installation of Single-DIN and Double-DIN radios
- Integrated hazard button and passenger airbag indicator
- Painted to match the factory finish

KIT COMPONENTS

- A) Radio trim panel with tactile display
- B) Radio brackets
- C) Pocket
- D) Engine start/stop circuit board and cover
- E) Engine start/stop trim
- F) #8 x 3/8" Phillips truss-head screws (4)
- G) #4 x 1/2" Phillips pan-head screws (6)
- H) Panel clips (4)
- I) Blank panels (5), Cooled seat buttons (L & R), Heated seat buttons (L & R), Heated steering wheel
- J) USB cable
- K) HVAC interface and wiring harness (not shown)
- L) Antenna adapter (not shown)

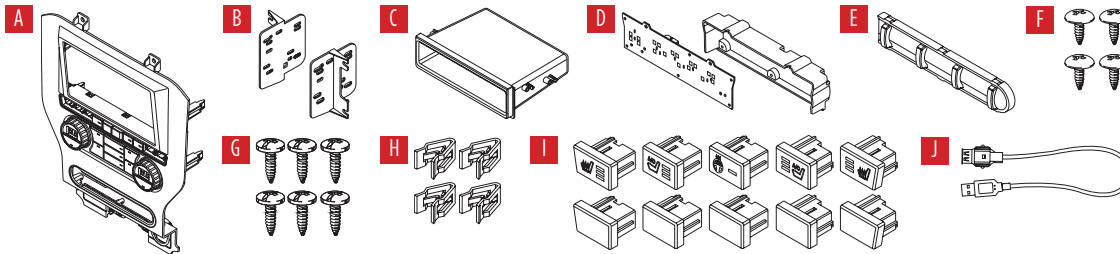

TABLE OF CONTENTS

Dash Disassembly.....	2-3
Kit Preparation.....	4-5
Kit Assembly	
–ISO DIN radio provision with pocket.....	6
–ISO DDIN radio provision	6
Axxess Interface installation	7-18
Final Assembly.....	10

WIRING & ANTENNA CONNECTIONS

Wiring Harness: Axxess interface and harness included
 Antenna Adapter: Included in kit

TOOLS REQUIRED

- Panel removal tool
- Phillips screwdriver
- 9/32" socket wrench
- Cutting tool
- Torx T-10 screwdriver

Attention! With the key out of the ignition, disconnect the negative battery terminal before installing this product. Ensure that all installation connections are secure before cycling the ignition to test this product.

DASH DISASSEMBLY

1. Open the passenger door and remove the trim panel from the side of the dash. (Figure A)
2. Open the glove box and remove the trim panel on the right side. (Figure B)
3. Unclip and remove the trim/vent dash panel. (Figure C)

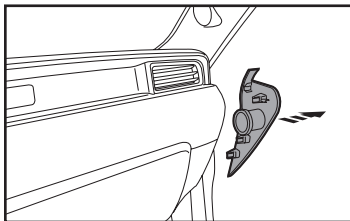

(Figure A)

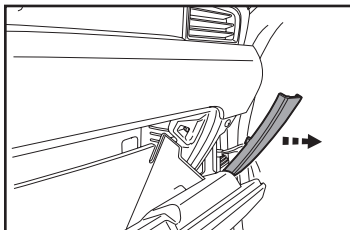

(Figure B)

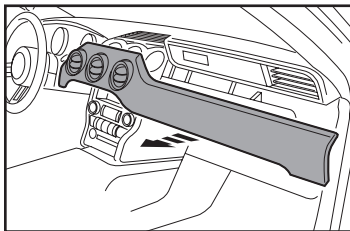

(Figure C)

4. Remove the rubber tray cover in front of the shifter, and then remove the (2) 9/32" screws exposed. (Figure D)
5. Unclip and remove the front side panels from each side of the center console. (Figure E)
6. Remove the (2) 9/32" screws from each side of the center console. (Figure F)

Continued on the next page

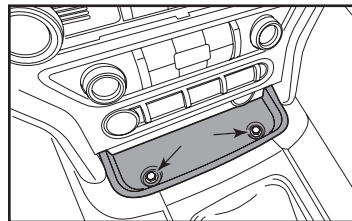

(Figure D)

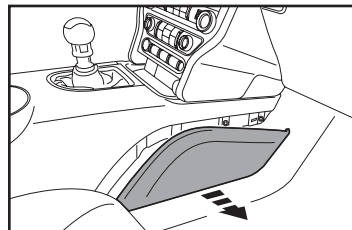

(Figure E)

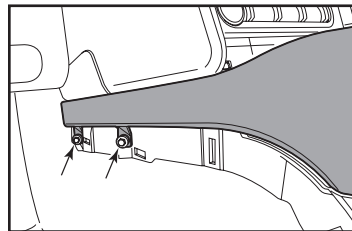

(Figure F)

DASH DISASSEMBLY (CONT.)

- Unclip the shifter trim bezel and slightly pull it up to clear the center console trim bezel removal.
- Open the center console storage compartment. Unclip the center console trim bezel, then slide it toward the rear of the vehicle to remove it. (Figure G)

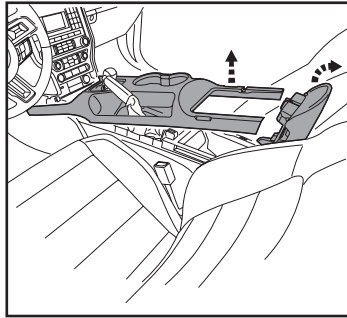

(Figure G)

- Note:** The complete center console does not need to be removed, but if it is desired to be removed, the Push-to-Start module must be connected when testing the kit.
- Remove the plastic tray in front of the shifter.
 - Remove the center plastic trim (knockout) between the power outlet and USB jack. (Figure H)

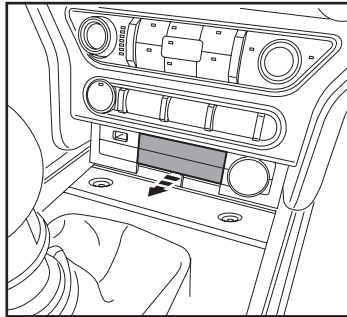

(Figure H)

Ensure that the vehicle is completely off before proceeding onto the following (3) steps:

- Remove the (4) 9/32" screws securing the radio/climate control panel, and then unclip, unplug, and remove. (Figure I)
- Remove the (4) 9/32" screws securing the display screen, then unplug and remove. (Figure J)
- Remove the (4) 9/32" screws securing the radio chassis, then unplug and remove. (Figure J)

Continue to Kit Preparation

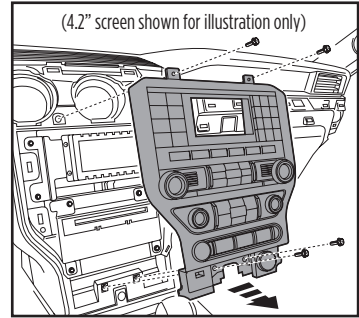

(Figure I)

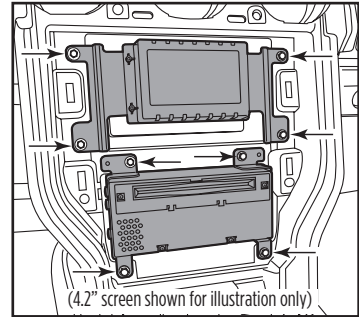

(Figure J)

KIT PREPARATION

1. Cut and remove the shaded area from the sub-dash to allow clearance for the aftermarket radio. (Figure A)

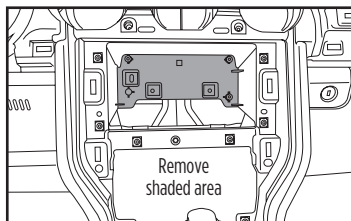

(Figure A)

From the factory radio/climate control panel:

1. Remove the (10) T-10 Torx screws securing the plastic panel cover to the rear of the panel, and then remove. (Figure B)
2. Remove the (5) T-10 Torx screws securing the circuit board, and then remove. (Figure C)

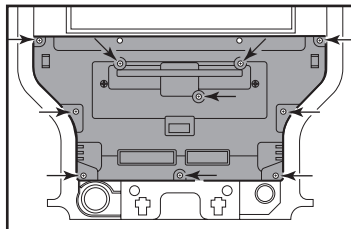

(Figure B)

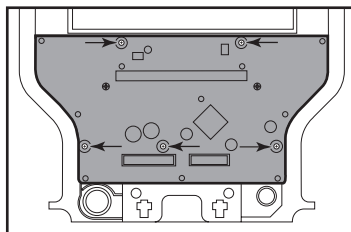

(Figure C)

3. Remove the rubber button membrane from the back of the engine start/stop switch panel. (Figure D)
4. Remove the engine start/stop switch panel. (Figure E)
5. Press in on the (2) retaining tabs inside the power outlet to remove the inner portion, and then unsnap the outer ring and cover. (Figure F)

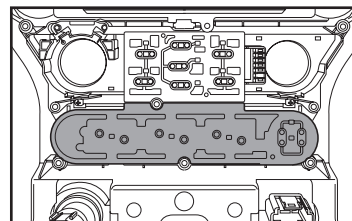

(Figure D)

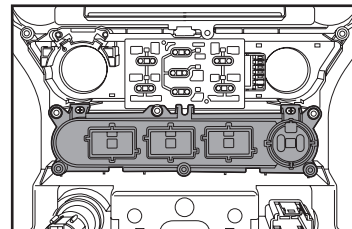

(Figure E)

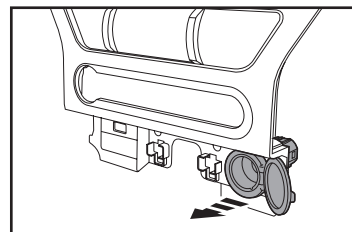

(Figure F)

Continued on the next page

KIT PREPARATION (CONT.)

To the 99-5866CH radio trim panel:

1. Attach the **engine start/stop trim**.
Note: engine start/stop trim is for 2018-2022 models. Attach the **engine start/stop switch panel**, and then the **rubber button membrane**. (Figure G)
2. Secure the **engine start/stop circuit board and cover** to the switch/cover assembly using the (6) #4 x 1/2" Phillips pan-head screws provided. (Figure H)

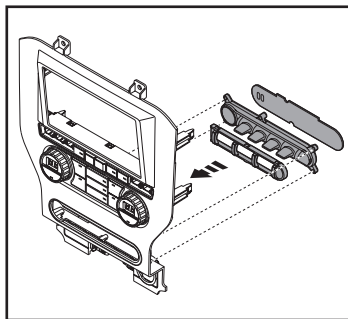

(Figure G)

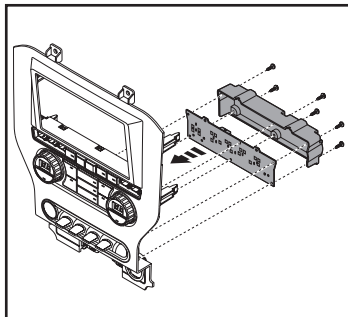

(Figure H)

3. Attach the (4) **panel clips** provided. (Figure I)
4. Insert the **USB cable** into the USB slot, through the rear. (Figure J)
5. **For models with heated seats, cooled seats and a heated steering wheel:**
Clip in the **heated seats, cooled seats and heated steering wheel buttons**. (Figure K)

For models without heated seats, cooled seats and a heated steering wheel: Clip in the **blank panels**. (Figure K)

Continue to Kit Assembly

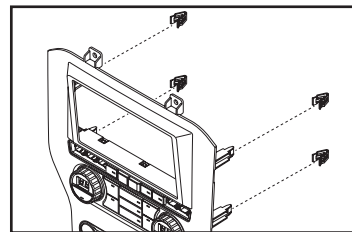

(Figure I)

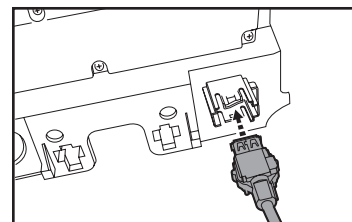

(Figure J)

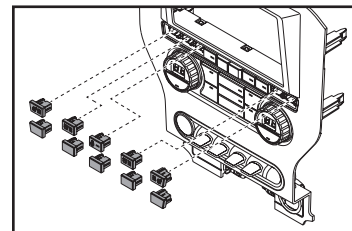

(Figure K)

KIT ASSEMBLY

ISO DIN radio provision with pocket

1. Attach the **pocket** to the **radio brackets** using the (4) #8 x 3/8" Phillips truss-head screws provided. (Figure A)
2. Remove the metal DIN sleeve and trim ring from the aftermarket radio.
3. Slide the radio into the bracket/pocket assembly, and then secure it using the screws supplied with the radio. (Figure B)

*Continue to Axcess
Interface Installation*

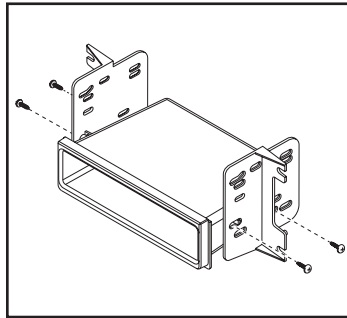

(Figure A)

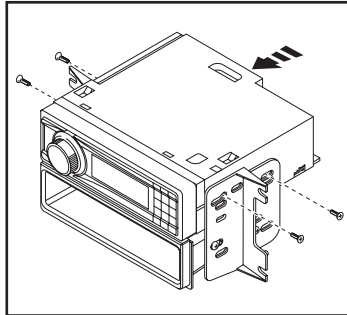

(Figure B)

ISO DDIN radio provision

1. Attach the **radio brackets** to the radio using the screws supplied with the radio. (Figure A)

*Continue to Axcess
Interface Installation*

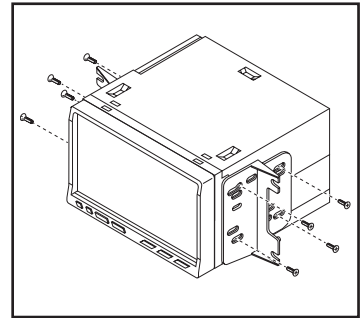

(Figure A)

AXXESS INTERFACE INSTALLATION

INTERFACE FEATURES

- Provides accessory power (12-volt 10-amp)
- Retains R.A.P. (retained accessory power)
- Provides NAV outputs (parking brake, reverse, speed sense)
- Retains audio controls on the steering wheel
- Retains the factory backup camera
- Retains balance and fade
- Micro “B” USB updatable

INTERFACE COMPONENTS

- Car side harness (LD-TSCREEN-FD3)
- HVAC interface
- HVAC harness (LD-FDHVAC)
- 16-pin harness with stripped leads (LD-2NAVAMPL)
- 54-pin backup camera harness (LD-FD54CAM)
- Female 3.5mm connector with stripped leads (LD-SWC-F3.5)
- AUX in harness (LD-FDAUX)

TABLE OF CONTENTS

Connections to be made	8-9
Installation	10
Programming.....	10
App instructions.....	11-12
Bluetooth configuration options.....	13-14
Configuration menu	15-17
Tech notes	18

TOOLS REQUIRED

- Crimping tool and connectors, or solder gun, solder, and heat shrink
- Tape • Wire cutter • Zip ties

CONNECTIONS TO BE MADE

From the 16-pin harness with stripped leads to the aftermarket radio, connect as indicated:

- **Red** wire to the accessory wire.
- **Orange/White** wire to the illumination wire. (if applicable).
- **Gray** wire to the right front (+) speaker output.
- **Gray/Black** wire to the right front (-) speaker output.
- **White** wire to the left front (+) speaker output.
- **White/Black** wire to the left front (-) speaker output.

Tape off and disregard the following wires, they will not be used in this application:

Blue/White, Green, Green/Black, Purple, Purple/Black, Brown

The following (3) wires are only for multimedia/navigation radios that require these wires.

- Connect the **Blue/Pink** wire to the VSS/speed sense wire.
- Connect the **Green/Purple** wire to the reverse wire.
- Connect the **Light Green** wire to the parking brake wire.
- Tape off and disregard the following (1) wire, it will not be used in this application: **Brown**

From the car side harness to the aftermarket radio, connect as indicated:

- **Black** wire to the ground wire.
- **Yellow** wire to the battery wire.
- **Green** wire to the left rear (+) speaker output.
- **Green/Black** wire to the left rear (-) speaker output.
- **Purple** wire to the right rear (+) speaker output.
- **Purple/Black** wire to the right rear (-) output.
- **Blue** wire to the power antenna wire.

Disregard the following:

- **Red** and **White** RCA's labeled FROM 3.5 & RSE/SYNC/SAT

Continued on the next page

3.5mm jack - steering wheel control retention:

The 3.5mm jack is to be used to retain audio controls on the steering wheel control.

- **For the radios listed below:** connect the included **female 3.5mm connector with stripped leads**, to the male 3.5mm SWC jack from the car side harness. Any remaining wires tape off and disregard.
 - **Eclipse:** Connect the steering wheel control wire, normally **Brown**, to the **Brown/White** wire of the connector. Then connect the remaining steering wheel control wire, normally **Brown/White**, to the **Brown** wire of the connector.
 - **Metra OE:** Connect the steering wheel control Key 1 wire (**Gray**) to the **Brown** wire.
 - **Kenwood** or select JVC with a steering wheel control wire: Connect the **Blue/Yellow** wire to the **Brown** wire.
Note: If the **Kenwood** radio auto detects as a **JVC**, manually set the radio type to **Kenwood**. See the instructions under changing radio type.
 - **XITE:** Connect the steering wheel control SWC-2 wire from the radio to the Brown wire.
 - **Parrot Asteroid Smart or Tablet:** Connect the 3.5mm jack into the AX-SWC-PARROT (sold separately), and then connect the 4-pin connector from the AX-SWC-PARROT into the radio.
Note: The radio must be updated to rev. 2.1.4 or higher software.
 - **Universal “2 or 3 wire” radio:** Connect the steering wheel control wire, referred to as Key-A or SWC-1, to the **Brown** wire of the connector. Then connect the remaining steering wheel control wire, referred to as Key-B or SWC-2, to the **Brown/White** wire of the connector. If the radio comes with a third wire for ground, disregard this wire.
Note: After the interface has been programmed to the vehicle, refer to the manual provided with the radio for assigning the SWC buttons. Contact the radio manufacturer for more information.
- **For all other radios:** Connect the 3.5mm jack into the port on the radio designated for an external steering wheel control interface. Refer to the manual provided with the radio if in doubt as to where the 3.5mm jack goes to.

OE Backup Camera Retention:

- Connect one side of the **supplied camera retention harness** to the 54 pin connector in the vehicle. This connector was removed from the factory 8” screen.
- Connect the two pin plug to the 14-pin AUX plug (LD-FD-AUX)
- Connect the **Yellow** RCA jack to the backup camera input from the aftermarket radio.

INSTALLATION

Climate control panel

1. Connect the radio wiring and place the radio assembly into the dash.
2. Route the passenger airbag light plug under the radio and connect to the radio trim panel.
3. Connect the **16-pin harness** with stripped leads into **Port A**.
4. Connect the **14-pin harness** with stripped lead, 6 pin and 2 pin into **Port B**.
5. **Port D** is a Micro-B USB input for updating the interface.
6. Connect the Airbag adaptor harness to the **6-pin harness** and then connect the **4-pin flat connector** to the airbag.
7. Connect the flat **6-pin harness** to the vehicle disregarding the **Gray 6-pin** and **Black 2-pin harness**.

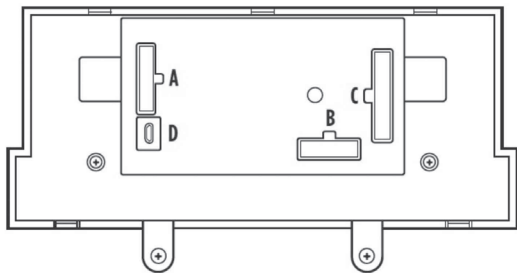

PROGRAMMING

1. Connect the **car side harness** into **Port C**, and then to the wiring harnesses in the vehicle.
Note: This is a timed process.
Cycle ignition on.
Note: The right knob should show DZ (or a 2). If not, select that option using the steps below.
2. Turning the **left knob** will guide you through the options on “kit”
3. Turn **right knob** to change setting for that option.
4. Turn **right knob** to cycle through your options until you find the “done” option.
5. Press the “Dual” button exit (“Dual button will act as an Enter button”)

Synchronizing hazards

Hazards must be programmed to match the pulse pattern of the factory lights, proceed:

1. With the ignition on, hold the **Hazard button** for (5) seconds until the pattern matches the factory ones.
2. Once the pattern is matched, let go of the **Hazard button**.
3. Test all functions of the installation for proper operation, before reassembling the dash.

FINAL ASSEMBLY

1. Using the factory screws, secure the radio in the dash, then attach the **radio trim panel** provided with this kit.
2. Reassemble the dash in the reverse order of disassembly to complete the installation.

APP INSTRUCTIONS

Download and install the AX-CUSTOM-BT app from the Android/Apple mobile devices app store.

QR Codes for downloading of APP



Vehicle Settings Screen

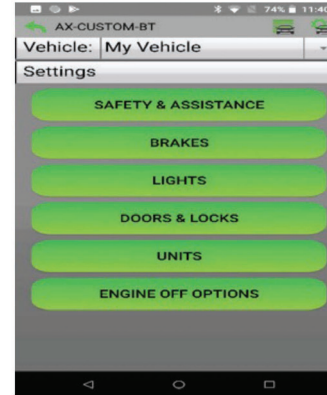

(Figure A)

1. Start the vehicle.
2. Open the app wait for the **Customization Settings** menu to appear.
(If **Not Connected**) appears instead, press the right button in the top right corner of the screen, then press the left button in the top right corner of the screen to go back to **Customization Settings**. The pairing process will begin at this point.
3. Once paired, **Settings** will be displayed on the screen. From this point on you can make changes to the vehicle as desired, as long as the vehicle is on. (Figure A)

Note: Screenshot shown for illustration only.
Actual options available vary per vehicle and trim level.

Continued on the next page

APP INSTRUCTIONS (CONT.)

Manage Vehicles Screen

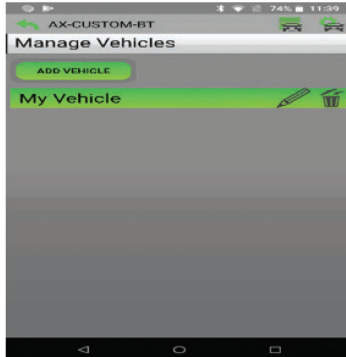

(Figure B)

1. Select **Manage Vehicles** by pressing the button in the top right of the screen. (Figure B)
2. Pressing either the Add Vehicle or Edit (pencil icon) button will open the **Configure Vehicle** menu. (Figure C)

Configure Vehicle Screen

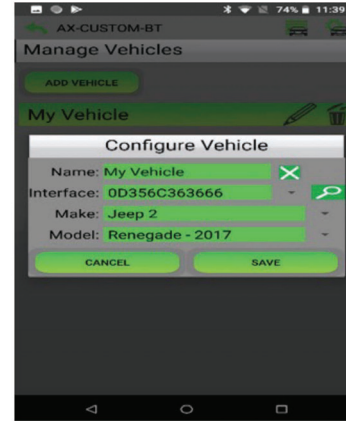

(Figure C)

- The name of the vehicle can be changed by pressing the text field.
- The app can automatically detect the interface installed in the vehicle by pressing the **Search** button (magnifying glass).
- The **Make and Model** fields will open a drop down list for the user to select the make and model of the vehicle that the interface is installed in.
- Press the Save button to store the changes.

BLUETOOTH CONFIGURATION OPTIONS

Available Options

Unit Settings	(Number of Zones)	Customization	Radio (type)	
(Backlight Color)	• Single Zone	(Ambient Lighting)	1 Eclipse (Type 1)	12 Eclipse (Type 2)
• Off	• Dual Zone	• Off	2 Kenwood 2	13 LG
• Red		• Ice Blue	3 Clarion (Type 1)	14 Parrot 4
• Orange		• Orange	4 Boss (type 1)/Dual/Sony 1 (Boss)	15 XITE
• Yellow		• Light Blue	5 JVC	16 Philips
• Lime Green		• Red	6 Pioneer/Jensen	17 Kicker
• Green		• Green	7 Alpine 3	18 JBL
• Cyan		• Blue	8 Boss (type 4)/Visteon 1 (Boss)	19 Insane Audio
• Blue		• Purple	9 Valor	20 Magnadyne
• Purple			10 Clarion (Type 2)	21 Boss (type 3)
• Magenta			11 Boss (Type 2)	22 Axxera

Continued on the next page

BLUETOOTH CONFIGURATION OPTIONS *(CONT.)*

SWC button remap

Note: Not all options are available, please refer to aftermarket's radio owner's manual for available commands from radio

- SEEK UP button remap
- SEEK DOWN button remap
- MODE/SOURCE button remap
- MUTE button remap
- PRESET UP button remap
- PRESET DOWN button remap
- POWER button remap
- BAND button remap
- PLAY/ENTER button remap
- PTT button remap
- ON HOOK button remap
- OFF HOOK button remap

SWC button dual press

Note: Not all options are available, please refer to vehicle's owners' manual for buttons that came equipped from vehicle

- SEEK UP button dual press
- SEEK DOWN button dual press
- MODE/SOURCE button dual press
- MUTE button dual press
- PRESET UP button dual press
- PRESET DOWN button dual press
- POWER button dual press
- BAND button dual press
- PLAY/ENTER button dual press
- PTT button dual press
- ON HOOK button dual press
- OFF HOOK button dual press

Continued on the next page

CONFIGURATION MENU

The buttons on the steering wheel will be used to enter, navigate, and make changes to the Configuration Menu in the kit. The display on the climate knobs will be used to view the menu.

1. With the driver's door open, press and hold the **OK** button (right side), then cycle the key on.
2. Press the **Seek Up** and **Seek Down** buttons to toggle through the menu options available.
Refer to the **Menu Options** table for a list of options, and description of each option.
3. Navigate to "d o", then press the **OK** button to exit the Configuration Menu.
4. If no activity after 10-seconds the Configuration Menu will close.

Menu Options

Left Knob Display	Right Knob Display	Description
A.L	Will display current state	Ambient Lighting
A.G		OEM Amplifier Gain
A.S.		Auto Stop/Start Override
r.d		Radio Detection
b.L.		Backlight
U O		Version Number of Kit
d o	n E	Done/Quit

Sub-Menu Options

Ambient Lighting

Left Knob Display	Right Knob Display	Ambient lighting Color
A.L	lb	Ice Blue
A.L	Or	Orange
A.L	Sb	Soft Blue
A.L	rd	Red
A.L	Gr	Green
A.L	bL	Blue
A.L	PU	Purple

OEM Amplifier Gain

Left Knob Display	Right Knob Display
A.G	0 to 30

Auto Stop/Start Override

Left Knob Display	Right Knob Display	
A.S	0.0	Disabled (no over-ride)
A.S	0.1	Enabled

CONFIGURATION MENU (CONT.)

Steering Wheel Controls

- Press the **OK** button on the steering wheel to start the auto detection process.
1. If the steering wheel controls don't work properly it is possible to change the radio type.
 2. Get to the **radio type** sub menu. Rotate the right climate knob until the correct radio type is displayed on the knob display. Press the **MAX AC** button to set the new radio type.
 3. If the **AXSWC interface** flashes Red (7) times, and an **Alpine** radio is not installed, that means there is an open connection not accounted for. Verify that the 3.5mm jack is connected to the correct steering wheel jack/wire in the radio.
 4. The **AXSWCH-PAR** (sold separately) is required. Also, the software in the radio must be rev. 2.1.4 or higher.
 5. If a **Clarion** or **Eclipse** radio is installed and the steering wheel controls do not function, change the radio to **Clarion (type 2)** or **Eclipse (type 2)** respectively. If the steering wheel controls still do function, refer to the **Changing Radio Type** document available at axessinterfaces.com.
 6. If a **Kenwood** radio is installed and the L.E.D. feedback flashes (5) times instead of (2), manually change the radio type to **Kenwood**. To do this, refer to the **Changing Radio Type** document available at axessinterfaces.com.

Radio Detection

Left Knob Display	Right Knob Display	Radio Manufacturer	Keynotes
r.d	1	Eclipse (Type 1)	1
r.d	2	Kenwood	2
r.d	3	Clarion (Type 1)	1
r.d	4	Boss (type 1)/Dual/Sony	1 (Boss)
r.d	5	JVC	
r.d	6	Pioneer/Jensen	
r.d	7	Alpine	3
r.d	8	Boss (type 4)/Visteon	1 (Boss)
r.d	9	Valor	
r.d	10	Clarion (Type 2)	1
r.d	11	Boss (Type 2)	
r.d	12	Eclipse (Type 2)	1
r.d	13	LG	
r.d	14	Parrot	4
r.d	15	XITE	
r.d	16	Philips	
r.d	17	Kicker	
r.d	18	JBL	
r.d	19	Insane Audio	
r.d	20	Magnadyne	
r.d	21	Boss (type 3)	
r.d	22	Axxera	

CONFIGURATION MENU *(CONT.)*

Sub-Menu Options (cont.)

Backlight

Left Knob Display	Right Knob Display	Backlight Color
b.L	--	No backlight
b.L	rD	Red
b.L	Or	Orange
b.L	YE	Yellow
b.L	LG	Lime Green
b.L	Gr	Green
b.L	CY	Cyan
b.L	BL	Blue
b.L	Pu	Purple
b.L	HP	Hot Pink

Version Number of Kit

Left Knob Display	Right Knob Display
U0	Will display current version of kit

Done/Quit

- Press the **Mode/OK** button on the steering wheel to exit the Configuration Menu.

Left Knob Display	Right Knob Display
d o	n E

Resetting the interface

- Hold the “AUTO” & “DUAL” inner button on the left and right “LCD” knobs for 15 seconds.
- The LCDs will go blank and reset causing the interface to redetect the vehicle

Changing the temp from Fahrenheit to Celsius

(factory controls not effected by the Metra AXXESS product)

- The temperature can be changed from the instrument cluster of the vehicle by following the steps listed below. From the vehicle’s **Message Center** (if equipped, will be displaying on the left hand side of the instrument cluster) Using the left steering wheel controls to navigate through the message center, scroll down to the “**Settings**”, press “**Ok**”. There you will see “**Units**”, press “**Ok**”, then you will have the option to select Fahrenheit (°F) or Celsius (°C). Pressing the “**Ok**” button will select the temperature that is being displayed from vehicle on kit.

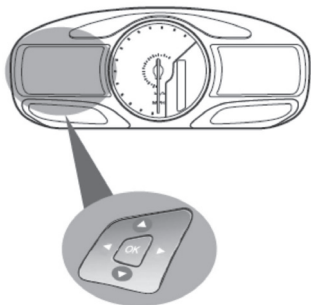

Scroll Up/Down to highlight one of the categories, then press the right arrow key or OK to enter into that category.

Main menu

From the main menu screen you can choose from the following categories:

- Display Mode
- Trip 1 & 2
- Fuel Economy
- ***Settings**
- Information

Under vehicle Settings

Units: Temperature

- Fahrenheit (°F)
- Celsius (°C)



99-5866CH
INSTALLATION INSTRUCTIONS



Having difficulties? We're here to help.



Contact our Tech Support line at:

386-257-1187



Or via email at:

techsupport@metra-autosound.com

Tech Support Hours (Eastern Standard Time)

Monday - Friday: 9:00 AM - 7:00 PM

Saturday: 10:00 AM - 5:00 PM

Sunday: 10:00 AM - 4:00 PM



**Metra recommends MECP
certified technicians**