



INSTALLATION INSTRUCTIONS FOR PART 99-7315

APPLICATIONS

Hyundai Tucson 2005-2009

99-7315

KIT FEATURES

- DIN Head Unit Provisions with Pocket
- ISO DIN Head Unit Provisions with Pocket

KIT COMPONENTS

A) Radio Housing w/ Pocket • B) ISO Brackets • C) Trim Plate

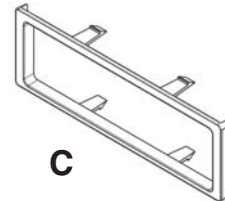
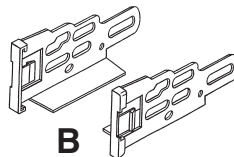
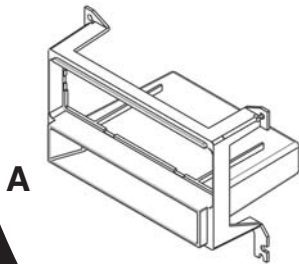

WIRING AND ANTENNA CONNECTIONS (Sold Separately)

Harness:

- 70-7301 - KIA / HYUNDAI 1999-2008

Antenna Adapter:

- Not Required

TOOLS REQUIRED:

Small Flat Blade Screwdriver • Phillips Screwdriver



1-800-221-0932



www.metraonline.com

© COPYRIGHT 2004-2009 METRA ELECTRONICS CORPORATION



99-7315

TABLE OF CONTENTS

<i>Dash Disassembly</i>	1-2
<i>Kit Assembly</i>	3-4
<i>Final Assembly</i>	5

2005-2009 HYUNDAI TUCSON

- 1** Disconnect the negative battery terminal to prevent an accidental short circuit.
- 2** Remove screw cover from back side of shift knob and remove (2) Phillips screws. Lift straight up on shift knob to remove. (Figure A)
- 3** Unclip and remove shift knob trim panel. (Figure B)
- 4** Remove (10) Phillips screws from dash support under shift knob trim panel and remove. (Figure C)

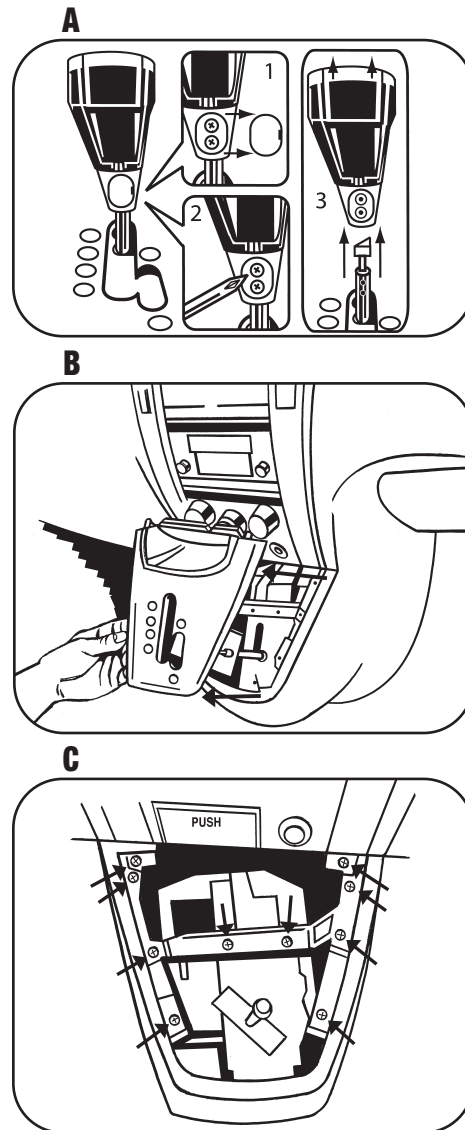

DASH DISASSEMBLY

DASH DISASSEMBLY**2005-2009 HYUNDAI TUCSON**

- 5** Remove (1) Phillips screw from bottom center of trim panel surrounding radio including a/c controls then unclip and remove panel. (Figure D-E)

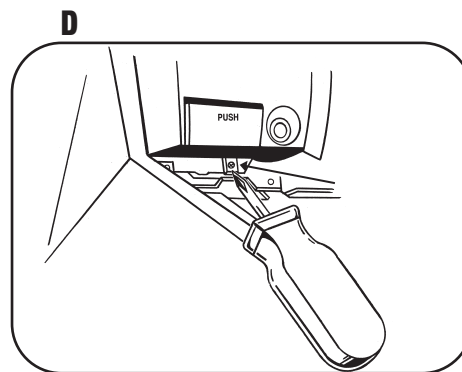

- 6** Remove (4) Phillips screws to remove radio. (Figure F)

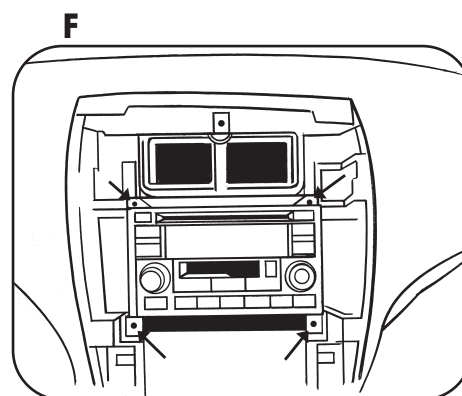
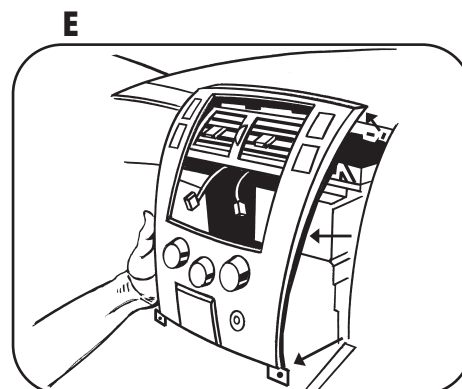

DIN HEAD UNIT PROVISIONS

- 1 Slide the DIN cage into the radio housing and secure by bending the metal locking tabs down. (Figure A)
- 2 Slide the aftermarket head unit into the cage and secure. (Figure B)
- 3 Snap the trim plate into the radio housing. (Figure B)

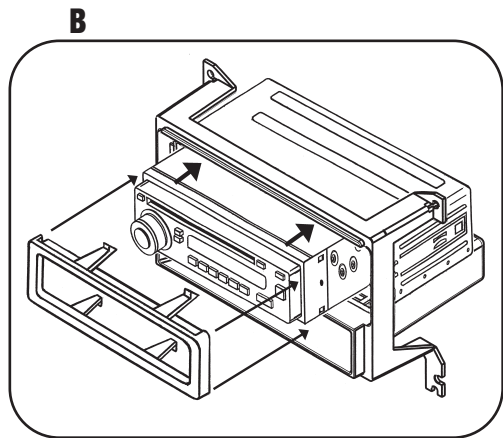
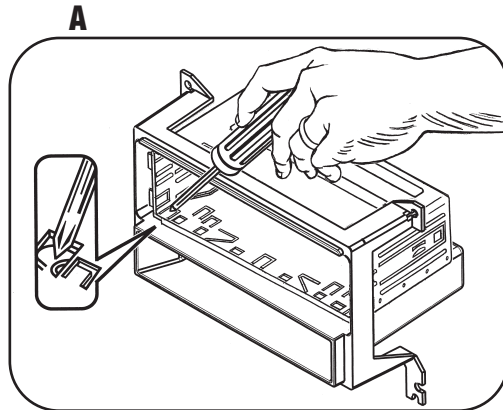

KIT ASSEMBLY

ISO DIN HEAD UNIT PROVISIONS

- 1 Mount the ISO Brackets to the head unit with the screws supplied with the unit. (Figure A)
- 2 Slide the head unit into the radio opening until the side clips engage. (Figure B)
- 3 Snap the trim plate into the radio housing. (Figure B)

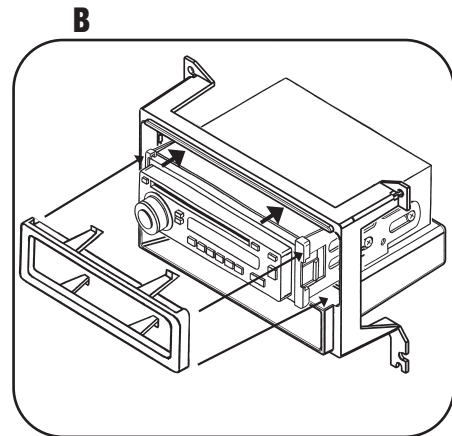
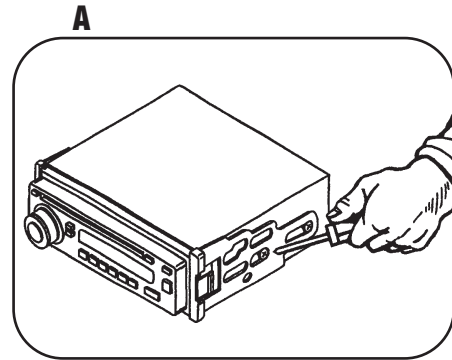

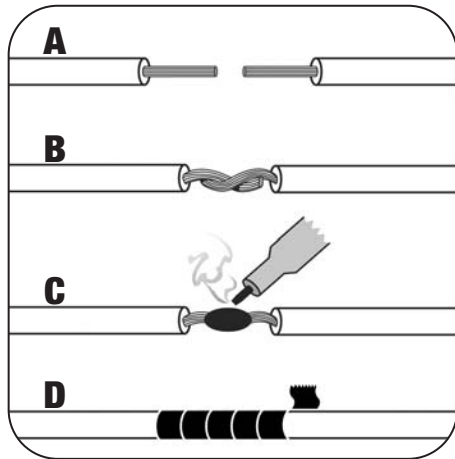

- A) Strip wire ends back 1/2"**
- B) Twist ends together**
- C) Solder**
- D) Tape**

FINAL ASSEMBLY

- 1** Locate the factory wiring harness in the dash. Metra recommends using the proper mating adapter and making the connections as shown. (Isolate and individually tape off the ends of any unused wires to prevent electrical short circuit)

- 2** Re-connect the negative battery terminal and test the unit for proper operation.

- 3** Reassemble radio and dash assemblies in reverse order of disassembly.

INST99-7315



1-800-221-0932



www.metraonline.com

REV. 06-18-09 © COPYRIGHT 2004-2009 METRA ELECTRONICS CORPORATION INST99-7315