



INSTALLATION INSTRUCTIONS FOR PART 99-7953

APPLICATIONS

Suzuki Grand Vitara 2006-up 99-7953

KIT FEATURES

- DIN head unit provision with pocket
- ISO DIN head unit provision with pocket



KIT COMPONENTS

- A) Radio housing • B) ISO brackets • C) Trim plate

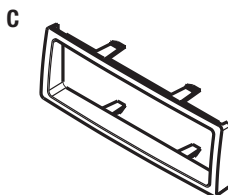
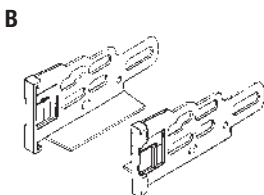
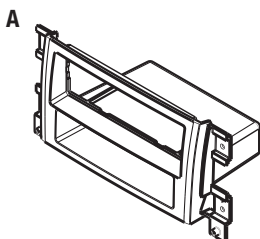

WIRING & ANTENNA CONNECTIONS (sold separately)

Wiring Harness:

- 70-1721 - Honda harness 1998-up

Antenna Adapter:

- Not required

TOOLS REQUIRED

- Small flat blade screwdriver • Phillips screwdriver • Socket wrench

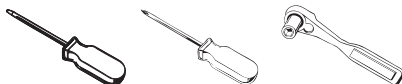

METRA. THE WORLD'S BEST KITS.™



1-800-221-0932



metraonline.com

© COPYRIGHT 2004-2011 METRA ELECTRONICS CORPORATION

REV. 4/10/12



99-7953

Table of Contents

Dash Disassembly

– Suzuki Grand Vitara 2006-up 3

Kit Assembly

– DIN head unit provision with pocket 4
– ISO DIN head unit provision with pocket 5

CAUTION: Metra recommends disconnecting the negative battery terminal before beginning any installation. All accessories, switches, and especially air bag indicator lights must be plugged in before reconnecting the battery or cycling the ignition.

Note: Refer to the instructions included with the aftermarket radio.



KNOWLEDGE IS POWER

Enhance your installation and fabrication skills by enrolling in the most recognized and respected mobile electronics school in our industry. Log onto www.installerinstitute.com or call 800-354-6782 for more information and take steps toward a better tomorrow.



Metra recommends MECP certified technicians

Suzuki Grand Vitara 2006-up

1. Unclip and remove the (2) outside trim panels. (Figure A)
2. Remove (6) Phillips screws securing the radio and climate controls to the sub dash. (Figure B)
3. Remove the (2) Phillips screws securing the factory radio bracket to the radio/ climate control assembly. (Figure C)
4. Separate the bracket and factory radio from the climate control. (Figure D)

Continue to kit assembly

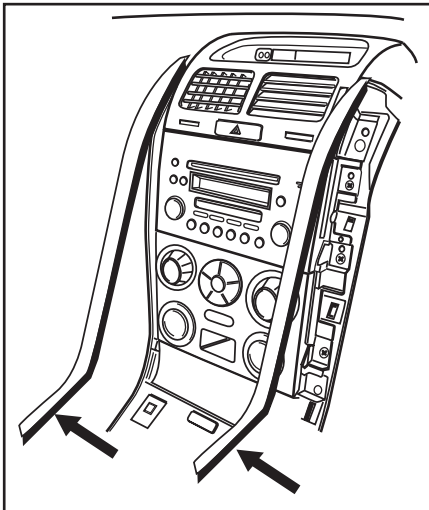

(Figure A)

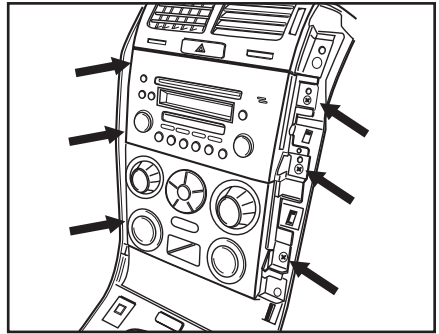

(Figure B)

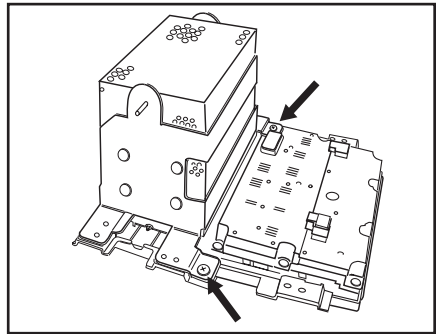

(Figure C)

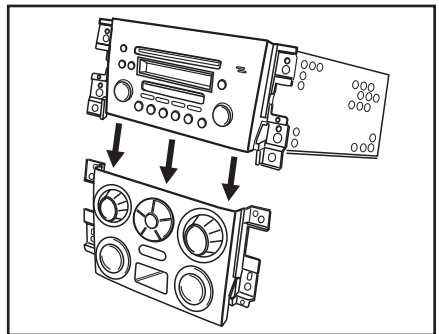

(Figure D)



Kit Assembly 99-7953

DIN head unit provision with pocket

1. Locate the factory wiring harness and antenna plug in the dash. Metra recommends using the proper mating adapters from Metra and/or AXCESS.
2. Slide the DIN cage into the radio housing and secure by bending the metal locking tabs down. (Figure A)
3. Slide the aftermarket head unit into the cage until secure. (Figure B)
4. Reassemble dash in reverse order of disassembly.

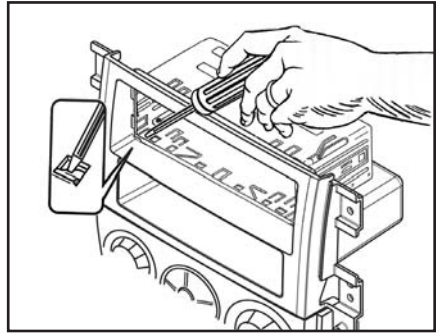

(Figure A)

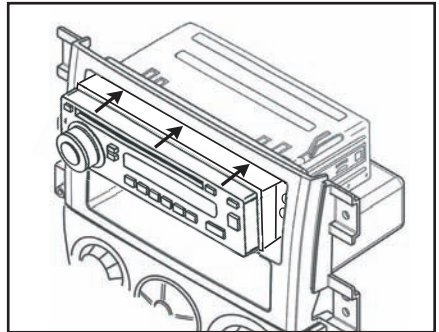

(Figure B)



Kit Assembly 99-7953

ISO DIN head unit provision with pocket

1. Locate the factory wiring harness and antenna plug in the dash. Metra recommends using the proper mating adapters from Metra and/or AXCESS.
2. Mount the ISO brackets to the head unit with the screws supplied with the unit. (Figure A)
3. Slide the head unit into the radio opening until the side clips engage. (Figure B)
4. Snap the trim plate into the radio housing. (Figure B)
5. Reassemble dash in reverse order of disassembly.

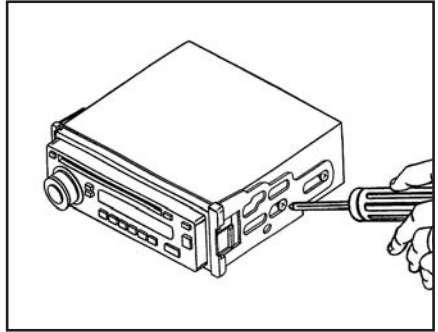

(Figure A)

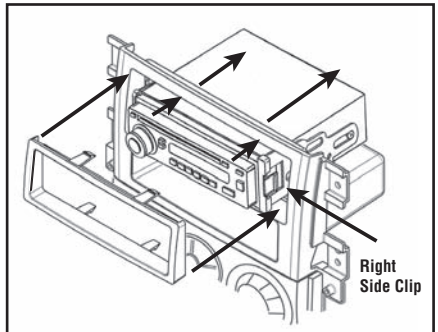

(Figure B)



INSTALLATION INSTRUCTIONS FOR PART 99-7953

REV. 4/10/12

METRA. THE WORLD'S BEST KITS.™



1-800-221-0932



metraonline.com

© COPYRIGHT 2004-2011 METRA ELECTRONICS CORPORATION



INSTRUCCIONES DE INSTALACIÓN PARA LA PIEZA 99-7953

APLICACIONES

Suzuki Grand Vitara 2006 y mas 99-7953

CARACTERÍSTICAS DEL KIT

- Provisiones de unidad central DIN con bolsillo
- Provisiones de unidad central ISO DIN con bolsillo



COMPONENTES DEL KIT

- A) Alojamiento del radio • B) Soportes ISO • C) Placa de moldura

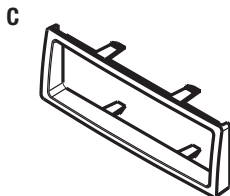
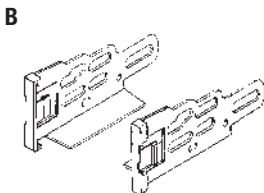
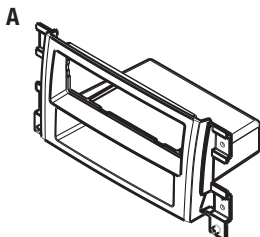

CABLEADO Y CONEXIONES DE ANTENA (se venden por separado)

Arnés de cableado:

- 70-1721 - Arnes Honda 1998 y mas

Adaptador de antena:

- No se requiere

HERRAMIENTAS REQUERIDAS

- Destornillador de hoja plana pequeño • Destornillador Phillips
- Herramienta toma de corriente

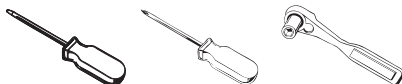

METRA. THE WORLD'S BEST KITS.™



1-800-221-0932



metraonline.com

© COPYRIGHT 2004-2011 METRA ELECTRONICS CORPORATION

REV. 5/4/12



99-7953

Indice

Desmontaje del tablero

- Suzuki Grand Vitara 2006 y más recientes 3

Ensamble del kit

- Provisiones de unidad central DIN con bolsillo 4
- Provisiones de unidad central ISO DIN con bolsillo 5

PRECAUCIÓN: *Metra recomienda desconectar el terminal negativo de la batería antes de comenzar cualquier instalación. Todos los accesorios, interruptores y, especialmente, las luces indicadoras de airbag deben estar enchufados antes de volver a conectar la batería o comenzar el ciclo de ignición.*

Nota: *Remítase a las instrucciones incluidas con el radio de posventa.*



EL CONOCIMIENTO ES PODER

Mejore sus habilidades de instalación y fabricación inscribiéndose en la escuela de dispositivos electrónicos móviles más reconocida y respetada de nuestra industria. Regístrese en www.installerinstitute.com o llame al 800-354-6782 para obtener más información y avance hacia un futuro mejor.



Metra recomienda técnicos con certificación del Programa de Certificación en Electrónica Móvil (Mobile Electronics Certification Program, MECP).

Suzuki Grand Vitara 2006 y mas

1. Desenganche y quite los (2) paneles exteriores de la moldura. (Figura A)
2. Quite los (6) tornillos Phillips que sujetan los controles del clima al sub tablero. (Figura B)
3. Quite los (2) tornillos Phillips que sujetan el soporte del radio de fábrica al ensamble del control de radio/clima. (Figura C)
4. Separe el soporte y el radio de fábrica del control de clima. (Figura D)

Continuará al ensamble del kit

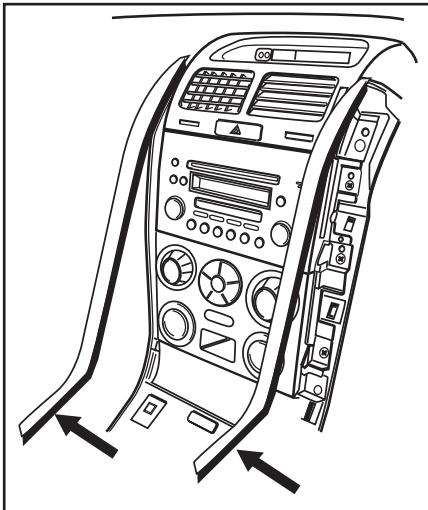

(Figura A)

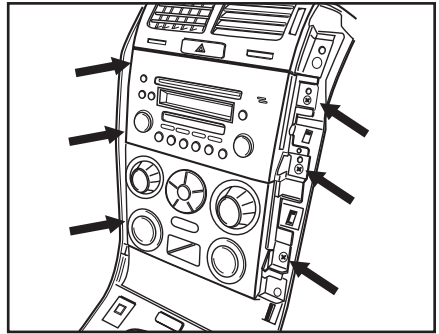

(Figura B)

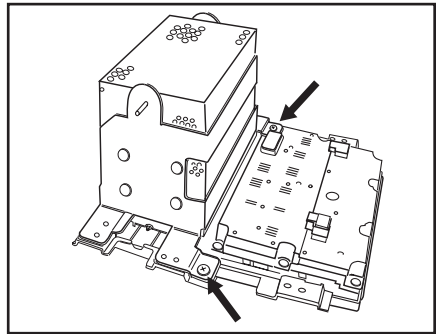

(Figura C)

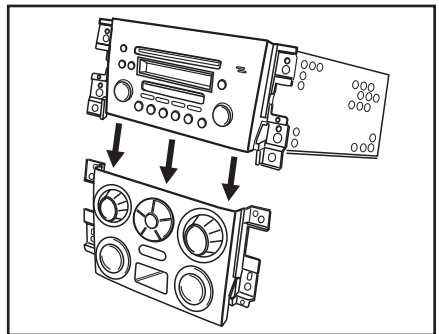

(Figura D)



Ensamble del kit 99-7953

Provisiones de unidad central DIN con bolsillo

1. Ubique el arnés del cableado de fábrica en el tablero. Metra recomienda usar el adaptador de acoplamiento adecuado de Metra o AXXESS.
2. Deslice la reja DIN en la carcasa del radio y sujétela doblando hacia abajo las pestañas de metal. (Figura A)
3. Deslice la unidad central de mercado secundario en la reja hasta que quede firme. (Figura B)
4. Vuelva a montar el tablero en forma inversa al desmontaje.

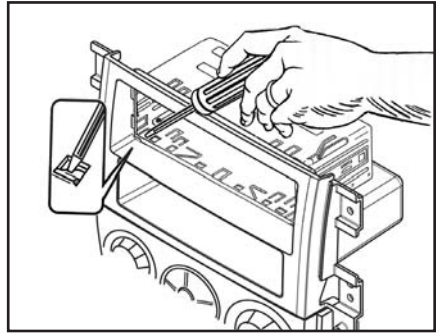

(Figura A)

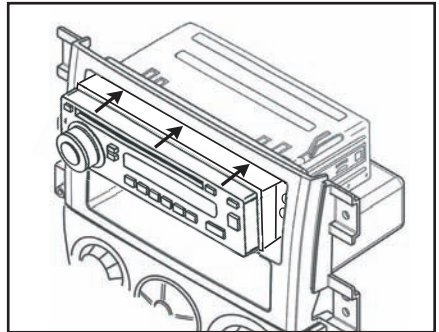

(Figura B)

Provisiones de unidad central ISO DIN con bolsillo

1. Ubique el arnés del cableado de fábrica en el tablero. Metra recomienda usar el adaptador de acoplamiento adecuado de Metra o AXXESS.
2. Monte los soportes ISO en la unidad central con los tornillos incluidos con la unidad. (Figura A)
3. Deslice la unidad central en la apertura del radio hasta que los ganchos laterales entren a presión. (Figura B)
4. Coloque a presión la placa de moldura ISO en la carcasa del radio. (Figura B)
5. Vuelva a montar el tablero en forma inversa al desmontaje.

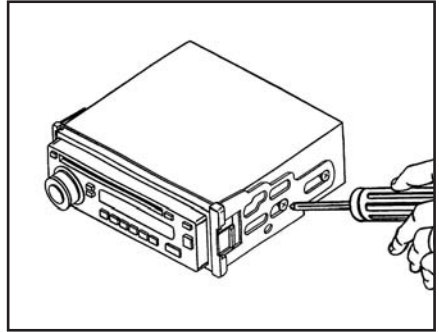

(Figura A)

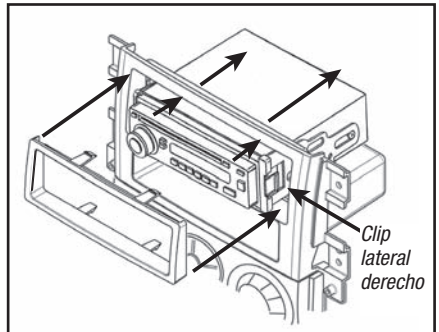

(Figura B)



INSTRUCCIONES DE INSTALACIÓN PARA LA PIEZA 99-7953

REV. 5/4/12

METRA. THE WORLD'S BEST KITS.™



1-800-221-0932



metraonline.com

© COPYRIGHT 2004-2011 METRA ELECTRONICS CORPORATION