

ALL VEHICLES

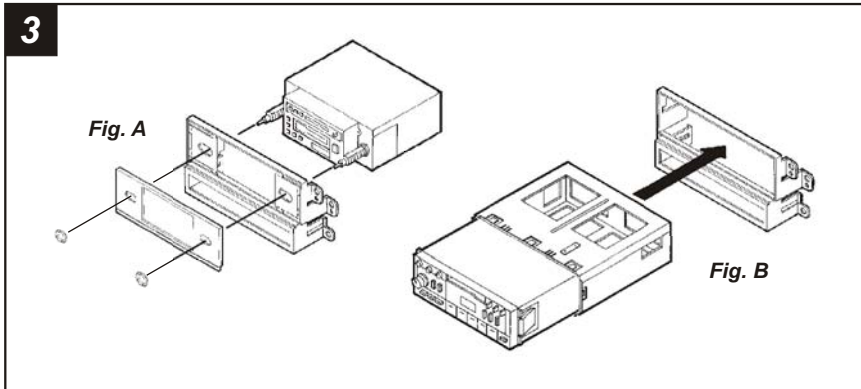

2-SHAFT HEAD UNITS: Attach the **Faceplate** to the **Radio Housing**. Slide the aftermarket head unit into the kit and secure with shaft nuts. (see Fig. A)

DIN HEAD UNITS: Cut and remove the shaft supports from the **Radio Housing**. Slide the DIN cage into the kit and secure by bending the metal locking tabs down. Slide the aftermarket head unit into the cage until secure. (see Fig. B)

(If an equalizer will be included, slide the unit into the back of the **Radio Housing** and secure. If an equalizer will NOT be included, snap the **Equalizer Dummy Plate** into the opening).

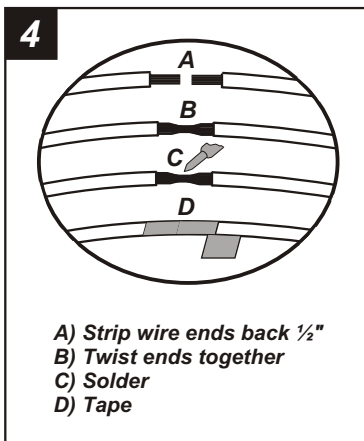

Locate the factory wiring harness in the dash. Metra recommends using the proper mating adaptor and making connections as shown. (Isolate and individually tape off the ends of any unused wires to prevent electrical short circuit).

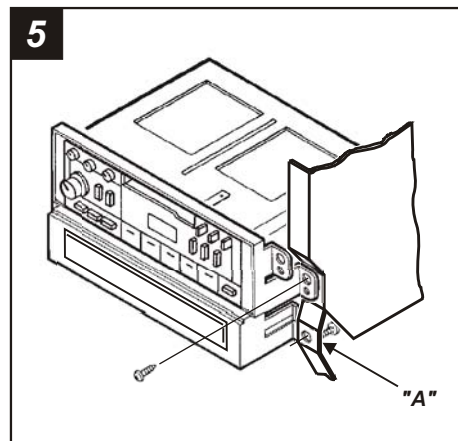

Re-connect the battery terminal and test the unit for proper operation. Mount the head unit/kit assembly to the sub-dash with (4) screws previously removed in step #1. (For the Standard Cab Pickup 1992-95, slide the lower mounting tabs behind the dash bracket and secure from behind ("A").) (see Fig. A)

KIT FEATURES

- ▶ Shaft and DIN unit provisions
- ▶ Equalizer provisions

KIT COMPONENTS

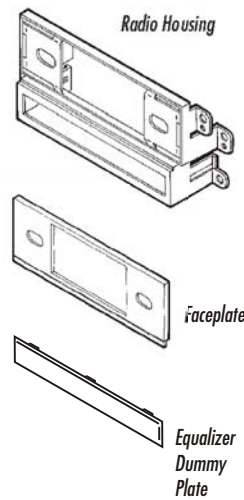

TOOLS REQUIRED



99-8140 INSTALLATION INSTRUCTIONS

APPLICATIONS

| CAR | PAGE |
|--------------------------------------|------|
| TOYOTA | |
| 4-Runner 1990-95..... | 1 |
| 4-Runner 1989-2002..... | 2 |
| Pickup (standard cab) 1989-2002..... | 1 |
| Pickup (extended cab) 1989-2002..... | 1 |
| T-100 1993-98..... | 1 |
| Tacoma 1995-01..... | 2 |



TOYOTA 4-Runner 1990-95
Pickup (standard cab) 1989-2002 / Pickup (extended cab) 1989-2002

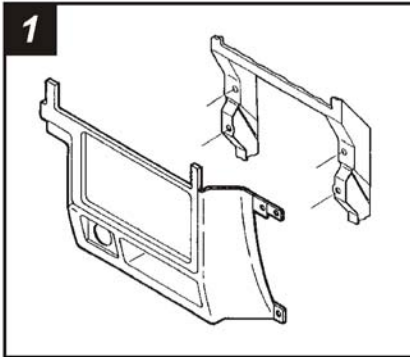

1
 Disconnect the negative battery terminal to prevent an accidental short circuit. Remove (3) screws and (1) 10mm bolt from the driver's side speaker panel and remove the panel. Remove (1) 10mm bolt from the bottom of the passenger's side speaker panel. Remove (3) screws from the side of the panel and remove the glove box. Remove (4) screws securing the factory head unit and disconnect the wiring.

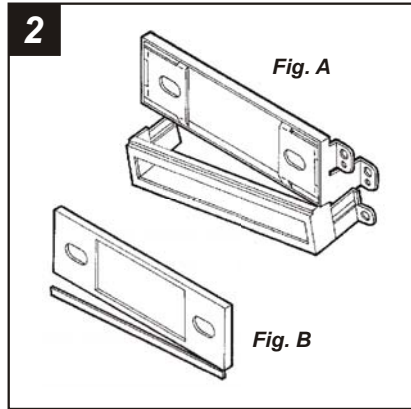

2
DOUBLE DIN APPLICATIONS: Skip to the Installation Instructions for ALL VEHICLES on Page #3.
SINGLE DIN APPLICATIONS: Cut and remove the bottom portion of the **Radio Housing** (see Fig. A) and **Faceplate** (see Fig. B). Skip to the Installation Instructions for ALL VEHICLES on Page #3.

TOYOTA 4-Runner 1989-2002

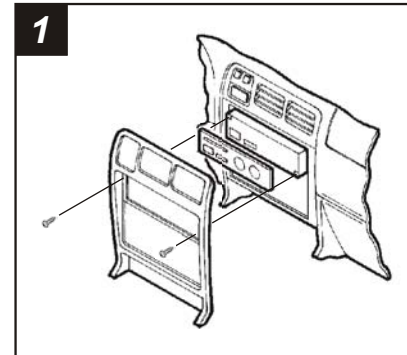

1
 Disconnect the negative battery terminal to prevent an accidental short circuit. Open the center armrest door. Unclip the parking brake trim panel. Unclip the gear shifter trim panel and remove the panel. Remove the climate control knobs. Remove the climate control trim plate and (2) Phillips screws exposed. Unclip the dash trim bezel and remove. Remove (4) Phillips screws securing the factory head unit and disconnect the wiring.

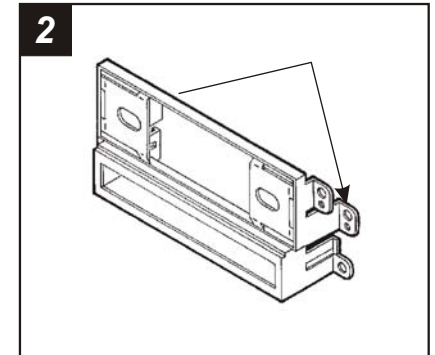

2
 Cut and remove the middle mounting legs on the **Radio Housing**. Skip to the Installation Instructions for ALL VEHICLES on Page #3.

TOYOTA T-100 1993-98

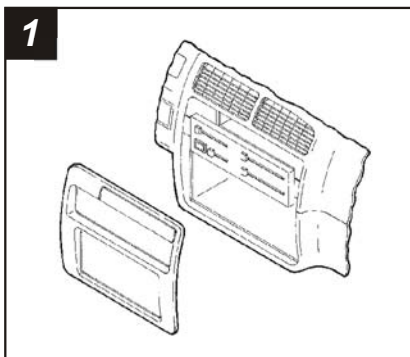

1
 Disconnect the negative battery terminal to prevent an accidental short circuit. Pull the cupholder out. Unclip the radio trim bezel and remove. Remove (4) screws securing the factory head unit and disconnect the wiring.

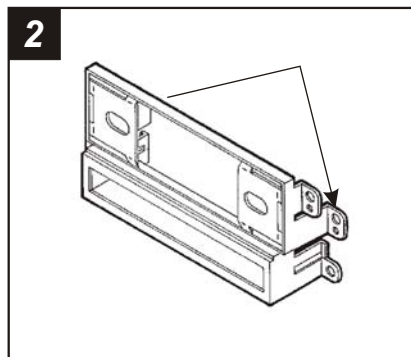

2
 Cut and remove the middle mounting legs on the **Radio Housing**. Skip to the Installation Instructions for ALL VEHICLES on Page #3.

TOYOTA Tacoma 1995-02

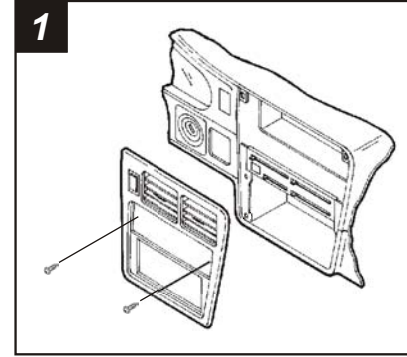

1
 Disconnect the negative battery terminal to prevent an accidental short circuit. Remove the climate control knobs. Unclip the climate control trim panel and remove (2) Phillips screws exposed. Unclip the dash trim bezel, lift up on the bezel and remove.

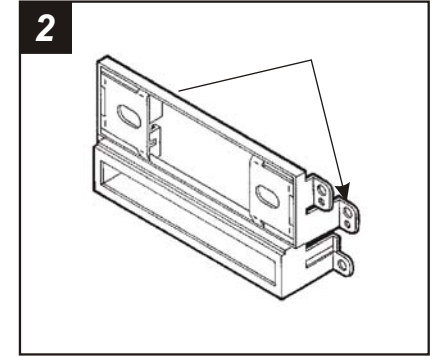

2
 Cut and remove the middle mounting legs on the **Radio Housing**. Skip to the Installation Instructions for ALL VEHICLES on Page #3.