



INSTALLATION INSTRUCTIONS FOR PART 99-8223

APPLICATIONS

Toyota Corolla 2009-2013 99-8223/99-8223S

KIT FEATURES

- ISO DIN radio provision with pocket
- *Painted to match factory dash*
- 99-8223 = Black, 99-8223S = Silver



KIT COMPONENTS

- A) Radio housing trim plate • B) Radio housing • C) Radio housing brackets • D) ISO Brackets
- E) ISO Trim plate

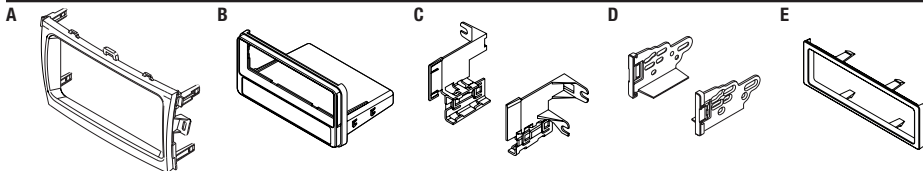

WIRING & ANTENNA CONNECTIONS (sold separately)

- Wiring Harness: • 70-1761 - Toyota harness 1987-up • TYTO-01 - LEX/TOY 2001-up amp interface
 Antenna Adapter: • 40-LX11 LEX/TOY 2002-up into car

TOOLS REQUIRED

- Panel removal tool • Phillips screwdriver • Small flat blade screwdriver

Table of Contents

Dash Disassembly

- Toyota Corolla 2009-2013 2

Kit Assembly

- ISO DIN radio provision with pocket..... 3

CAUTION: Metra recommends disconnecting the negative battery terminal before beginning any installation. All accessories, switches, and especially air bag indicator lights must be plugged in before reconnecting the battery or cycling the ignition.

NOTE: Refer to the instructions included with the aftermarket radio.

Dash Disassembly

1. Unclip and remove the (4) side trim panels from the right and left side of the radio and a/c controls. (Figure A)
2. Unclip and remove the a/c vent panel above the factory radio. (Figure B)
3. Remove (4) 10 mm bolts securing the radio. (Figure C)
4. Remove (8) screws securing the brackets to the factory radio and remove the brackets. Note, retain clips for re-use during kit assembly. (Figure D)
5. Remove (4) plastic clips from the back of the factory radio. Note, retain clips for re-use during kit assembly.

Continue to kit assembly

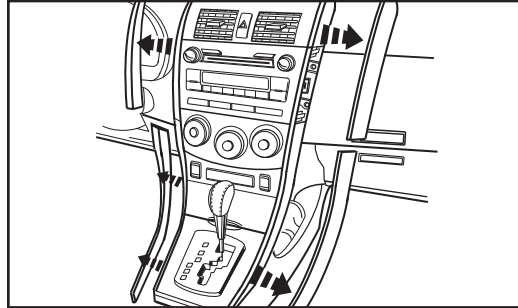

(Figure A)

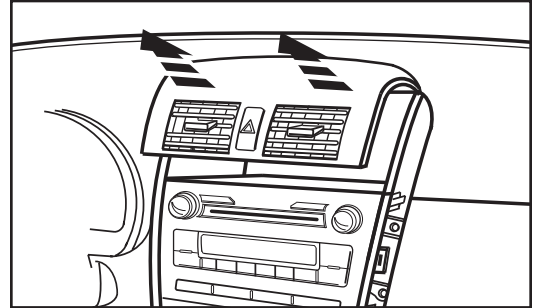

(Figure B)

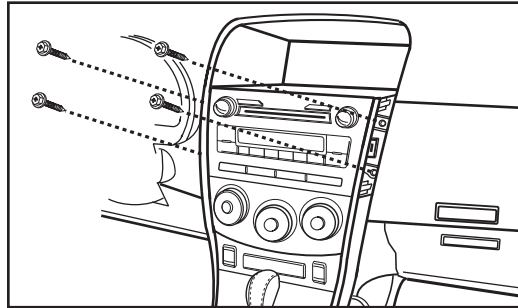

(Figure C)

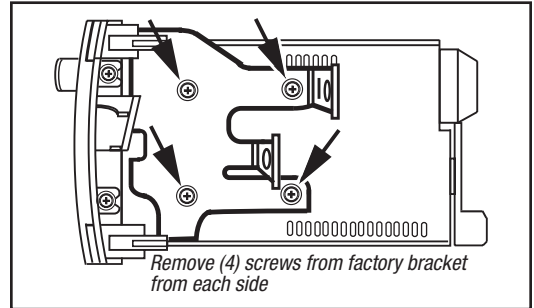

Remove (4) screws from factory bracket from each side

(Figure D)

Kit Assembly

ISO DIN radio provision with pocket

1. Attach the clips removed from the factory radio to the back of the radio housing trim plate. (Figure A)
2. Slide the radio housing brackets on the sides of the radio housing until the side clips engage. Note, tabs are marked Left and Right. (Figure B)
3. Mount the ISO brackets to the radio using the screws supplied with the radio. (Figure C)
4. Slide the radio into the radio housing until it snaps into place. (Figure D)
5. Snap the trim plate onto the front of the radio housing. (Figure D)
6. Locate the factory wiring harness in the dash. Metra recommends using the proper mating adapter from Metra or AXCESS. Re-connect the negative battery terminal and test the radio for proper operation.
7. Reassemble dash in reverse order of disassembly.

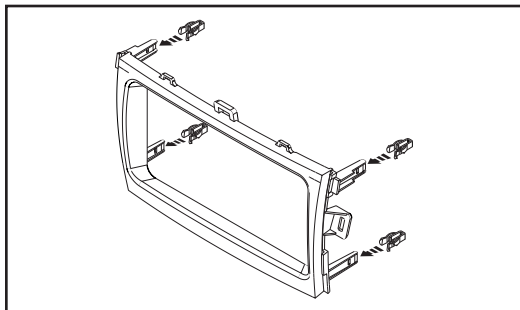

(Figure A)

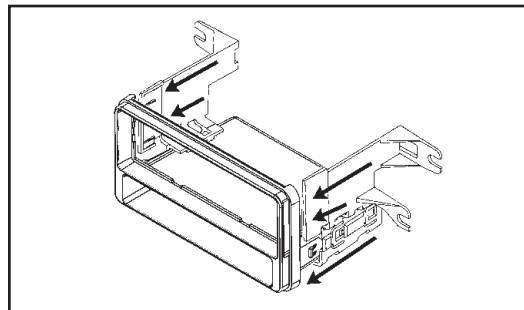

(Figure B)

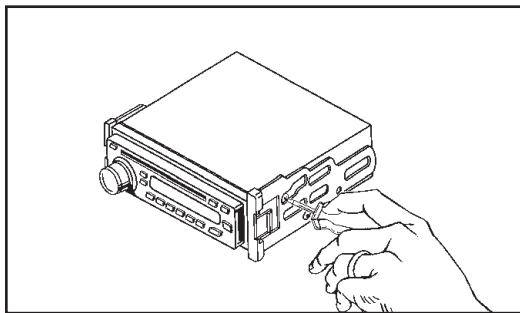

(Figure C)

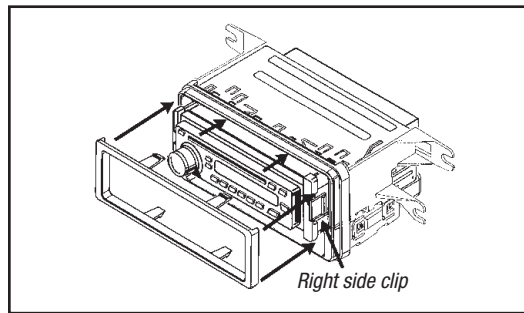

(Figure D)



INSTALLATION INSTRUCTIONS FOR PART 99-8223



REV. 3/24/2014 INST99-8223



KNOWLEDGE IS POWER

Enhance your installation and fabrication skills by enrolling in the most recognized and respected mobile electronics school in our industry. Log onto www.installerinstitute.com or call 800-354-6782 for more information and take steps toward a better tomorrow.



**Metra recommends MECP
certified technicians**



INSTRUCCIONES DE INSTALACIÓN PARA LA PIEZA 99-8223

APLICACIONES

Toyota Corolla 2009-2013 99-8223/99-8223S

CARACTERÍSTICAS DEL KIT

- Provisión de radio doble DIN ISO con bolsillo
- *Pintado para que coincida con el tablero de fábrica*
99-8223 = Black, 99-8223S = Silver



COMPONENTES DEL KIT

- A) Radio housing trim plate • B) Radio housing • C) Radio housing brackets • D) ISO Brackets
- E) ISO Trim plate

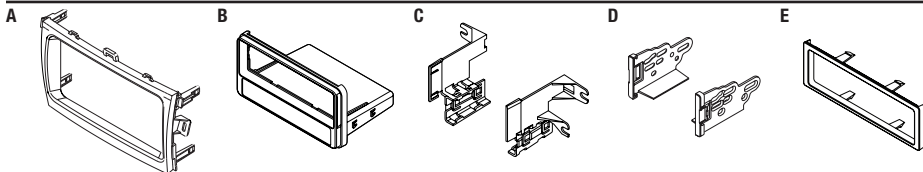

CABLEADO Y CONEXIONES DE ANTENA (se venden por separado)

Arnés de cableado: • 70-1761 - Toyota 1987 y mas • TYTO-01 - LEX/TOY 2001 y mas interfaz amplificador
Adaptador de antena: • 40-LX11 LEX/TOY 2002 y mas en el coche

HERRAMIENTAS REQUERIDAS

- Herramienta de remoción de panel • Destornillador Phillips • Destornillador plano pequeño

Índice

Desmontaje del tablero	
– Toyota Corolla 2009-2013	2
Ensamble del kit	
– Provisión de radio doble DIN ISO con bolsillo.....	3

PRECAUCIÓN: Metra recomienda desconectar el terminal negativo de la batería antes de comenzar cualquier instalación. Todos los accesorios, interruptores y, especialmente, las luces indicadoras de airbag deben estar enchufados antes de volver a conectar la batería o comenzar el ciclo de ignición.

NOTA: Remítase a las instrucciones incluidas con el radio de postventa.

Desmontaje del tablero

1. Suelte y retire los (4) paneles de ajuste lateral desde el lado derecho e izquierdo de los controles del radio y aire acondicionado. (Figura A)
2. Suelte y retire el panel de ventilación de aire acondicionado por encima de la radio de fábrica. (Figura B)
3. Retire (4) tornillos de 10 mm que fijan la radio. (Figura C)
4. Quitar (8) tornillos que fijan los soportes a la radio de fábrica y eliminar los corchetes. Nota, retener clips para su reutilización durante el montaje del kit. (Figura D)
5. Retire (4) abrazaderas de plástico de la parte posterior de la radio de fábrica. Nota, retener clips para su reutilización durante el montaje del kit.

Continuará al ensamble del kit

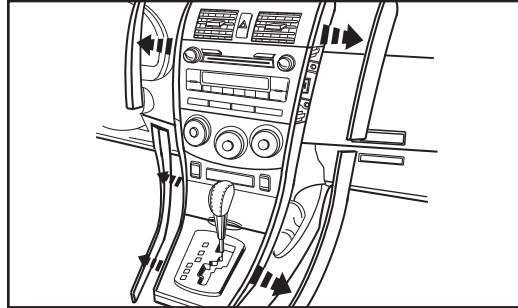

(Figura A)

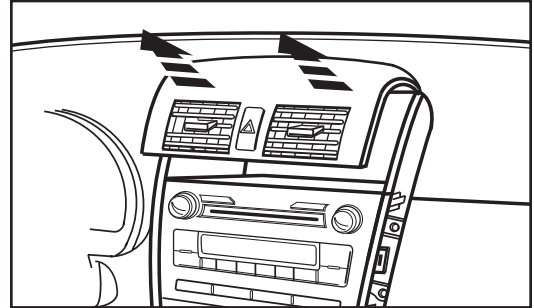

(Figura B)

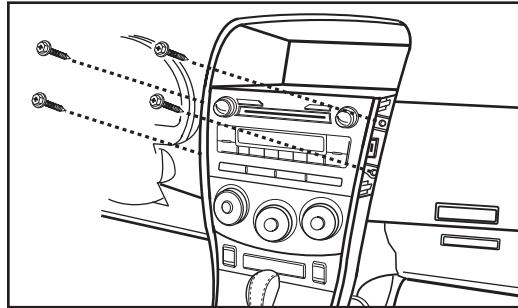

(Figura C)

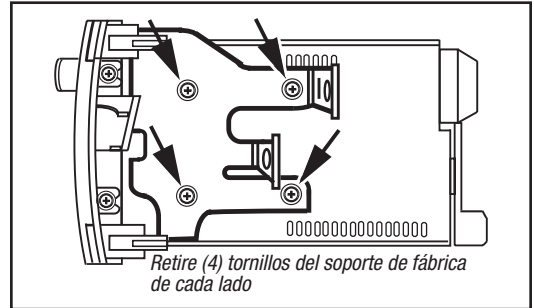

(Figura D)

Retire (4) tornillos del soporte de fábrica de cada lado

Ensamble del kit

Provisión de radio doble DIN ISO con bolsillo

1. Fije los clips extraídos de la radio de la fábrica a la parte posterior de la placa de montaje de la vivienda radio. (Figura A)
2. Deslice los soportes de cubierta de radio sobre los lados de la carcasa de la radio hasta que los ganchos laterales encajen. Nota, las pestañas están marcadas Izquierda (Left) y Derecha (Right). (Figura B)
3. Monte los soportes ISO en el radio con los tornillos que vienen con el radio. (Figura C)
4. Deslice el radio de mercado secundario en la reja hasta que entre a presión. (Figura D)
5. Coloque a presión la placa de la moldura al frente del ensamble/carcasa del radio. (Figura D)
6. Ubique el arnés del cableado de fábrica en el tablero. Metra recomienda usar el adaptador de acoplamiento adecuado de Metra o AXCESS. Vuelva a conectar el terminal negativo de la batería y pruebe la unidad para verificar que funcione correctamente.
7. Vuelva a montar el tablero en forma inversa al desmontaje.

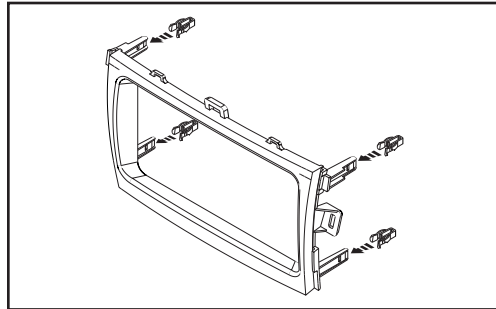

(Figura A)

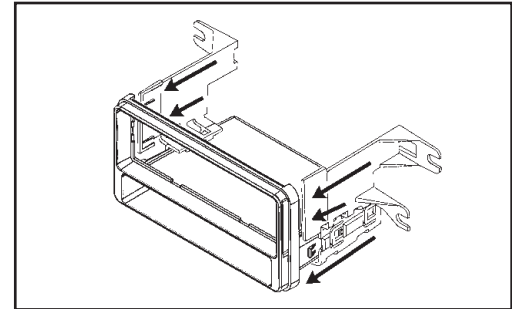

(Figura B)

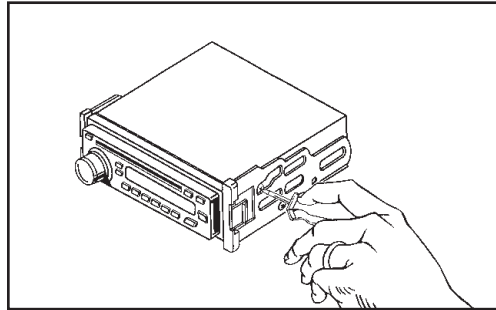

(Figura C)

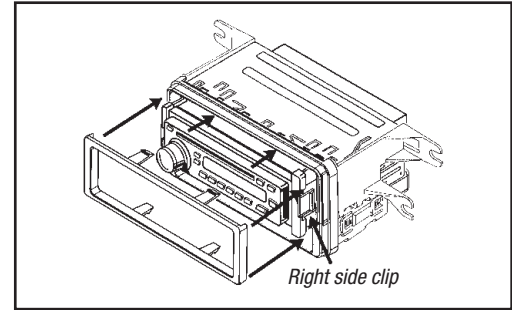

(Figura D)



INSTRUCCIONES DE INSTALACIÓN PARA LA PIEZA 99-8223



REV. 3/24/2014 INST99-8223



EL CONOCIMIENTO ES PODER
Mejore sus habilidades de instalación y fabricación inscribiéndose en la escuela de dispositivos electrónicos móviles más reconocida y respetada de nuestra industria. Regístrese en www.installerinstitute.com o llame al 800-354-6782 para obtener más información y avance hacia un futuro mejor.



Metra recomienda técnicos con certificación del Programa de Certificación en Electrónica Móvil (Mobile Electronics Certification Program, MECP).