

KIT FEATURES

- ▶ DIN head unit provisions

KIT COMPONENTS

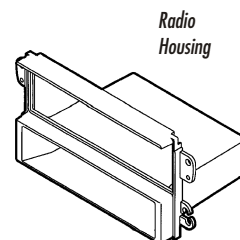

TOOLS REQUIRED



Phillips screwdriver



Cutting tool

99-8800

INSTALLATION INSTRUCTIONS

APPLICATIONS

CAR	PAGE
DAEWOO	
Lanos 1999-02.....	1-2
Leganza 1999-02.....	1-2
Nubira 1999.....	1-2
Nubira 2000-02.....	1-2



ALL VEHICLES

1

(LANOS SHOWN IN ILLUSTRATION)

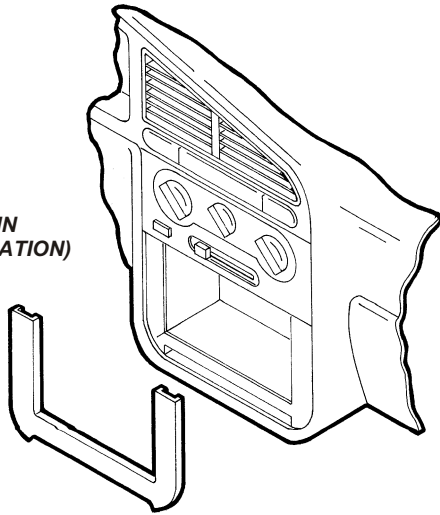

Disconnect the negative battery terminal to prevent an accidental short circuit. Unclip the radio trim bezel and remove. Remove (4) Phillips screws securing the factory head unit and disconnect the wiring.

2

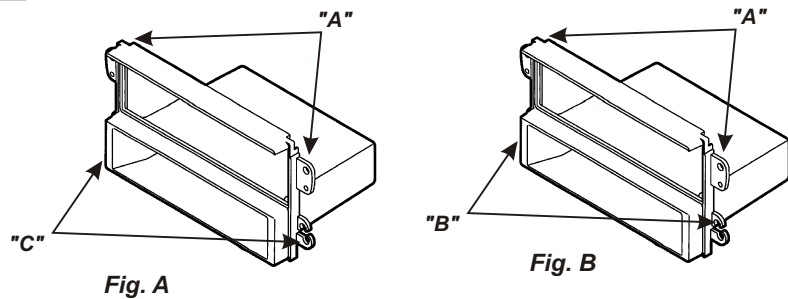

NUBIRA 1999, LANOS, LEGANZA: Cut and remove all mounting tabs on the Radio Housing EXCEPT tabs "A" and "C" (Fig. A). The tabs can be identified by the stamped letter on each tab.

NUBIRA 2000-01: Cut and remove all mounting tabs on the Radio Housing EXCEPT tabs "A" and "B" (Fig. B). The tabs can be identified by the stamped letter on each tab.

3

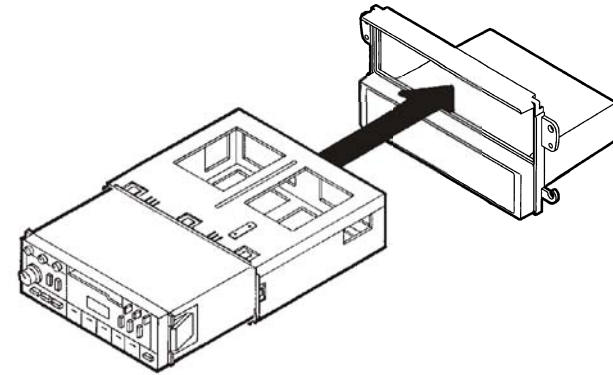

Slide the DIN cage into the kit and secure by bending the metal locking tabs down. Slide the aftermarket head unit into the cage until secure.

4

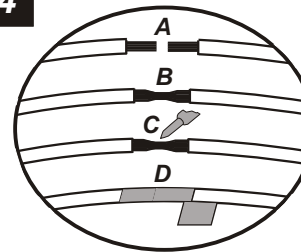

- A) Strip wire ends back 1/2"
- B) Twist ends together
- C) Solder
- D) Tape

Locate the factory wiring harness in the dash. Metra recommends using the proper mating adaptor and making connections as shown. (Isolate and individually tape off the ends of any unused wires to prevent electrical short circuit).

5

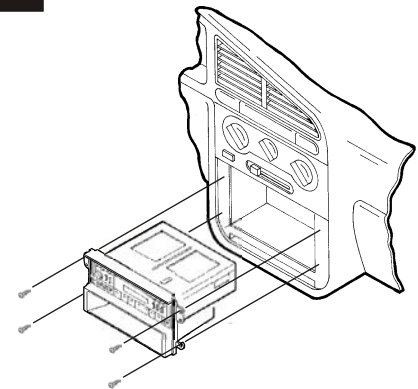

Re-connect the battery terminal and test the unit for proper operation. Mount the head unit/kit assembly to the sub-dash with (4) Phillips screws previously removed in step #1.