



INSTALLATION INSTRUCTIONS FOR PART 99-8902

APPLICATIONS

Subaru Forester/Impreza 2008-up 99-8902



KIT FEATURES

- DIN radio provision with pocket
- ISO radio provision with pocket

KIT COMPONENTS

- A) Radio housing • B) ISO Bracket • C) Trim plate

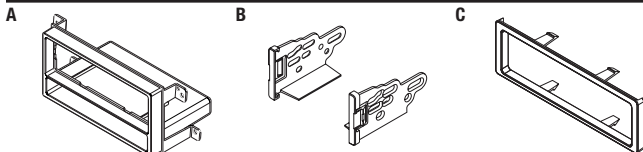

WIRING & ANTENNA CONNECTIONS (sold separately)

- Wiring Harness: • 70-7552 - Nissan/Subaru 2007-up • 70-8901 - Subaru 1990-up
• 70-8902 - Subaru 2012-up amp interface

- Antenna Adapter: • 40-SB10 - Subaru antenna adapter 2005-up

TOOLS REQUIRED

- Small flat blade screwdriver • Panel removal tool • Phillips screwdriver

Table of Contents

Dash Disassembly

- Subaru Forester (with DVD based NAV) 2009-2013.....2
- Subaru Forester 2009-20132
- Subaru Impreza WRX 2013-up2
- Subaru Impreza WRX STI 2008-2012.....2
- Subaru Impreza 2008-2011.....2

Kit Assembly

- DIN radio provision with pocket.....3
- ISO radio provision with pocket.....3

CAUTION: Metra recommends disconnecting the negative battery terminal before beginning any installation. All accessories, switches, and especially air bag indicator lights must be plugged in before reconnecting the battery or cycling the ignition.

NOTE: Refer to the instructions included with the aftermarket radio.

**Subaru Forester (with DVD based NAV) 2009-2013/Forester 2009-2013/
Impreza WRX 2013-up/Impreza WRX STI 2008-2012/
Subaru Impreza 2008-2011**

1. Unclip and remove the trim panel surrounding the factory radio including the A/C vents. (Figure A)
2. Remove (4) Phillips screws securing the radio. Unplug and remove the radio.

Continue to kit preparation

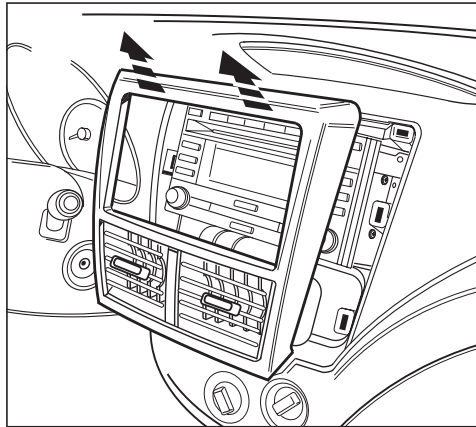

(Figure A)

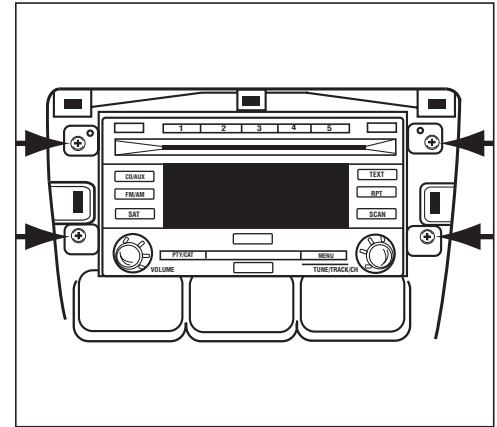

(Figure B)

DIN radio provision with pocket

1. Slide the DIN cage into the radio housing and secure by bending the metal locking tabs outward. (Figure A)
2. Slide the aftermarket radio into the cage until it snaps into place. (Figure B)
3. Locate the factory wiring harness in the dash. Metra recommends using the proper mating adapter from Metra or AXCESS. Re-connect the negative battery terminal and test the radio for proper operation.
4. Reassemble dash in reverse order of disassembly.

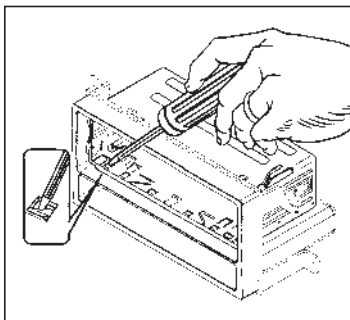

(Figure A)

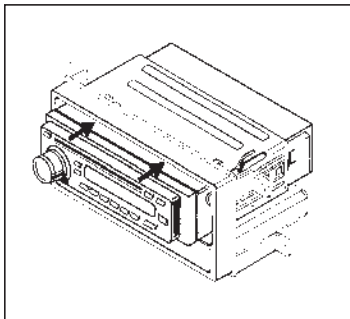

(Figure B)

ISO radio provision with pocket

1. Mount the ISO brackets to the radio using the screws supplied with the radio. (Figure A)
2. Slide the radio into the radio housing until it snaps into place. (Figure B)
3. Snap the trim plate onto the front of the radio housing. (Figure B)
4. Locate the factory wiring harness in the dash. Metra recommends using the proper mating adapter from Metra or AXCESS. Re-connect the negative battery terminal and test the radio for proper operation.
5. Reassemble dash in reverse order of disassembly.

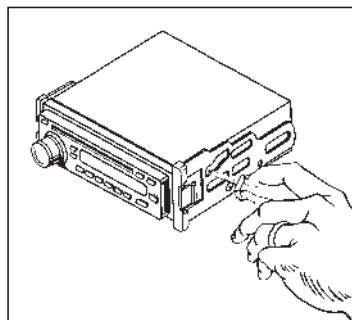

(Figure A)

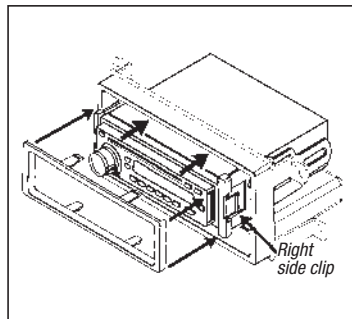

(Figure B)



INSTALLATION INSTRUCTIONS FOR PART 99-8902



REV 1/21/2014 INST99-8902



KNOWLEDGE IS POWER

Enhance your installation and fabrication skills by enrolling in the most recognized and respected mobile electronics school in our industry. Log onto www.installerinstitute.com or call 800-354-6782 for more information and take steps toward a better tomorrow.



**Metra recommends MECP
certified technicians**