



INSTALLATION INSTRUCTIONS FOR PART 99-8903B

APPLICATIONS

Subaru Legacy 2010-up Subaru Outback 2010-up

(For non-navigation radios only)

99-8903B

U.S. Patent # D639,795

KIT FEATURES

- DIN radio provision with pocket
- ISO radio provision with pocket
- **Painted scratch resistant Matte Black**



KIT COMPONENTS

- A) Radio Housing
- B) ISO Brackets
- C) Trim Plate

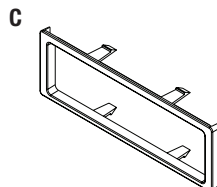
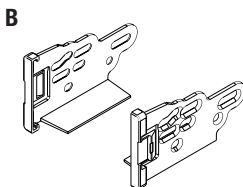
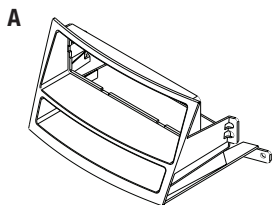

WIRING & ANTENNA CONNECTIONS (Sold Separately)

Wiring Harness:

- 70-8901 Subaru Harness 1990-Up
- 70-7552 Nissan Harness 2007-Up

Antenna Adapter:

- 40-SB10 Subaru Antenna Adapter 2005-Up

TOOLS REQUIRED

Panel Removal Tool • Phillips Screwdriver • Small Flat Blade Screwdriver • Socket Wrench



METRA. THE WORLD'S BEST KITS.™



1-800-221-0932



metraonline.com

© COPYRIGHT 2004-2011 METRA ELECTRONICS CORPORATION



99-8903B

Table of Contents

Dash Disassembly

- Subaru Legacy 2010-up.....3
- Subaru Outback 2010-up.....3

Kit Assembly

- DIN radio provision with pocket4
- ISO radio provision with pocket5

Caution

Metra recommends disconnecting the negative battery terminal before beginning any installation. All accessories, switches, and especially air bag indicator lights must be plugged in before reconnecting the battery or cycling the ignition.

**NOTE: Refer also to the instructions included with the aftermarket radio.*



KNOWLEDGE IS POWER

Enhance your installation and fabrication skills by enrolling in the most recognized and respected mobile electronics school in our industry. Log onto www.installerinstitute.com or call 800-354-6782 for more information and take steps toward a better tomorrow.



Metra recommends MECP certified technicians



99-8903B

Dash Disassembly

1. Unclip and remove the radio trim panel including the a/c vents. (Figure A)
2. Remove (4) Phillips screws securing the factory radio.

Continue to kit assembly

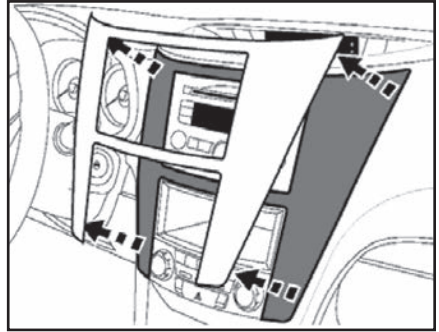

(Figure A)



Kit Assembly 99-8903B

DIN radio provision with pocket

1. Locate the factory wiring harness in the dash. Metra recommends using the proper mating adapter from Metra or AXXESS. Re-connect the negative battery terminal and test the unit for proper operation.
2. Slide the DIN cage into the radio housing and secure by bending the metal locking tabs down. (Figure A)
3. Slide the aftermarket head unit into the cage and secure. (Figure B)
4. Reassemble dash in reverse order of disassembly.

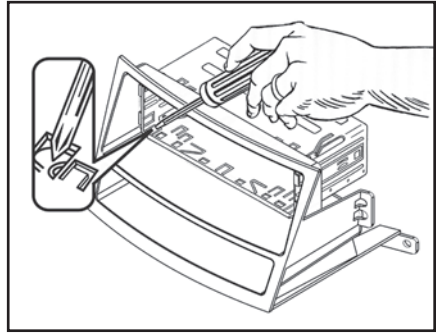

(Figure A)

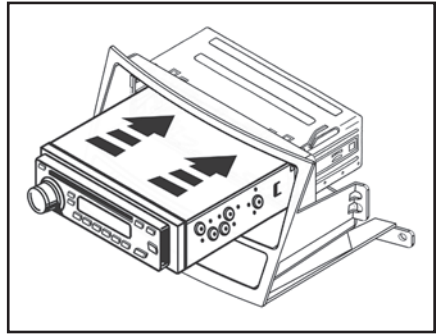

(Figure B)



Kit Assembly 99-8903B

ISO radio provision with pocket

1. Locate the factory wiring harness in the dash. Metra recommends using the proper mating adapter from Metra or AXXESS. Re-connect the negative battery terminal and test the unit for proper operation.
2. Mount the ISO brackets to the head unit with the screws supplied with the unit. (Figure A)
3. Slide the head unit into the radio opening until the side clips engage. (Figure B)
4. Snap the trim plate into the radio housing. (Figure B)
5. Reassemble dash in reverse order of disassembly.

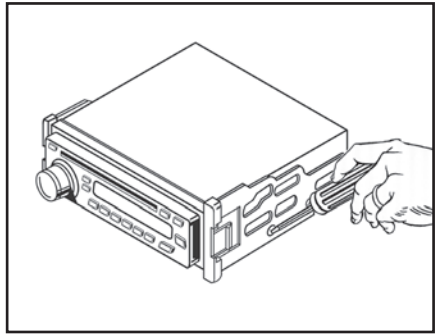

(Figure A)

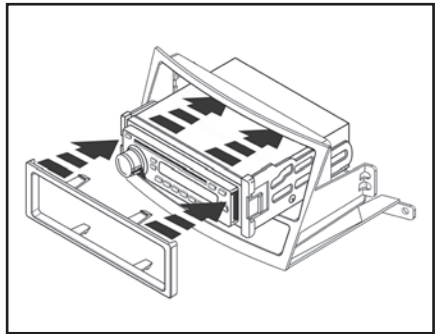

(Figure B)



INSTALLATION INSTRUCTIONS FOR PART 99-8903B

REV. 11/21/17

METRA. THE WORLD'S BEST KITS.™



1-800-221-0932



metraonline.com

© COPYRIGHT 2004-2011 METRA ELECTRONICS CORPORATION