

LOC T-Harnesses have vehicle specific applications. Please visit <https://axxessinterfaces.com/> for the latest and up-to-date application information.

### Things to know

Active noise cancellation is an OE module that helps reduce unwanted background noise. Microphones mounted throughout the vehicles are used to monitor sound levels and frequencies inside the vehicle's cabin. The factory ANC generates an inverted signal from the factory speakers to cancel out unwanted cabin noise.

It is recommended that the RPO code is double check to confirm application. The RPO Codes can be found on a placard labeled "Service Parts Identification" in the glove box, on the trunk floor or inside the driver's door panel.

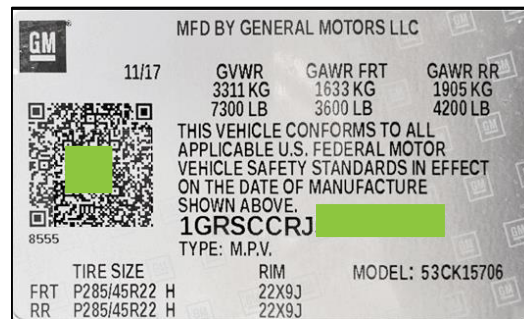

3GNAXKEV3 [REDACTED],2020,1XR26,02,20,X  
 ,XKWTVB, AG1 AG6 AR9 AXP AY0 CNQ  
 C4P DLF D31 EF7 FE9 FE9 FJW FWD GB8  
 GNA GND H1T UQA 20 J60 LYX MAH MNH  
 NB5 NTB N52 RJA RSB SJF SPM TB4 UDD  
 UZ6 U2K V8D WML ZP5 1LT 1LT 4AA 5CX  
 6X1 7X1 8X2 9X2,384A,,,,

### Active Noise Canceling Microphones (ANC)

Important Note: DO NOT PLUG in the ANC bypass into any other factory module other than the location mentioned below.

The Active Noise Cancellation system is operational under the following conditions:

The amplifier has passed all self diagnostic checks

- All doors are closed
- Battery voltage is between 9.5 V and 16 V
- The vehicle cabin temperature is less than 140°F (60°C)
- Engine speed is between 550 and 3000 RPM

To bypass the ANC you would need to remove the trunk carpet or liner and look for a small module connected to the vehicle's audio system or wiring harness. However, please note that the exact location may vary depending on the specific trim level and options of the Camaro. Simply unplug the OE connector from the AMP/ANC module and plug the t-harness inline. Your ANCs have been bypassed.

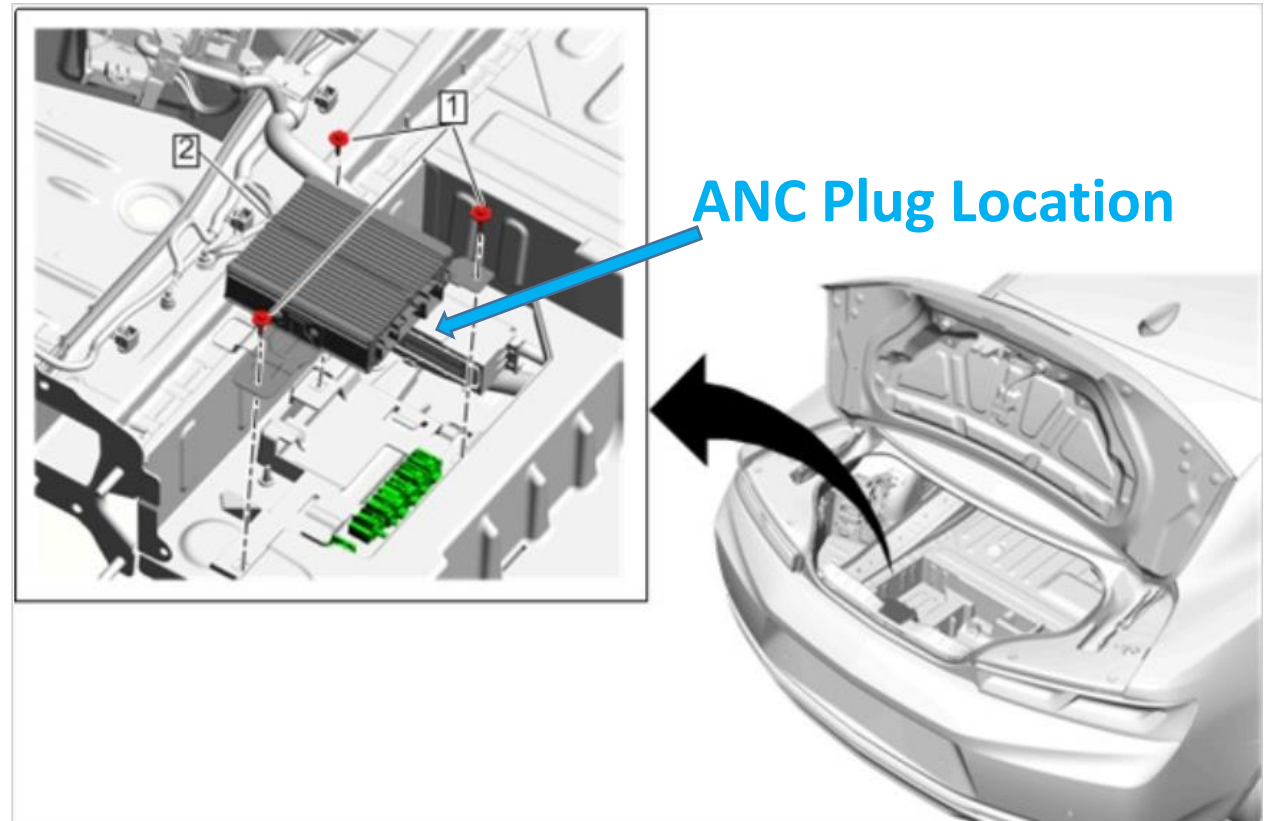

## Active Noise Canceling Microphones (ANC)

Important Note: DO NOT PLUG in the ANC bypass into any other factory module other than the location mentioned below.

The ANC system operates when certain conditions are met:

- The amplifier passes self-diagnostic checks.
- All doors are closed.
- Battery voltage is between 9.5 V and 16 V.
- Cabin temperature is below 140°F (60°C).
- Engine speed is between 550 and 3000 RPM.

To bypass the ANC you would need to remove the trunk carpet and rear passenger panel look for a small module connected to the vehicle's audio system or wiring harness. However, please note that the exact location may vary depending on the specific trim level and options of the Malibu. Simply unplug the OE connector from the AMP/ANC module and plug the t-harness inline. Your ANCs have been bypassed.

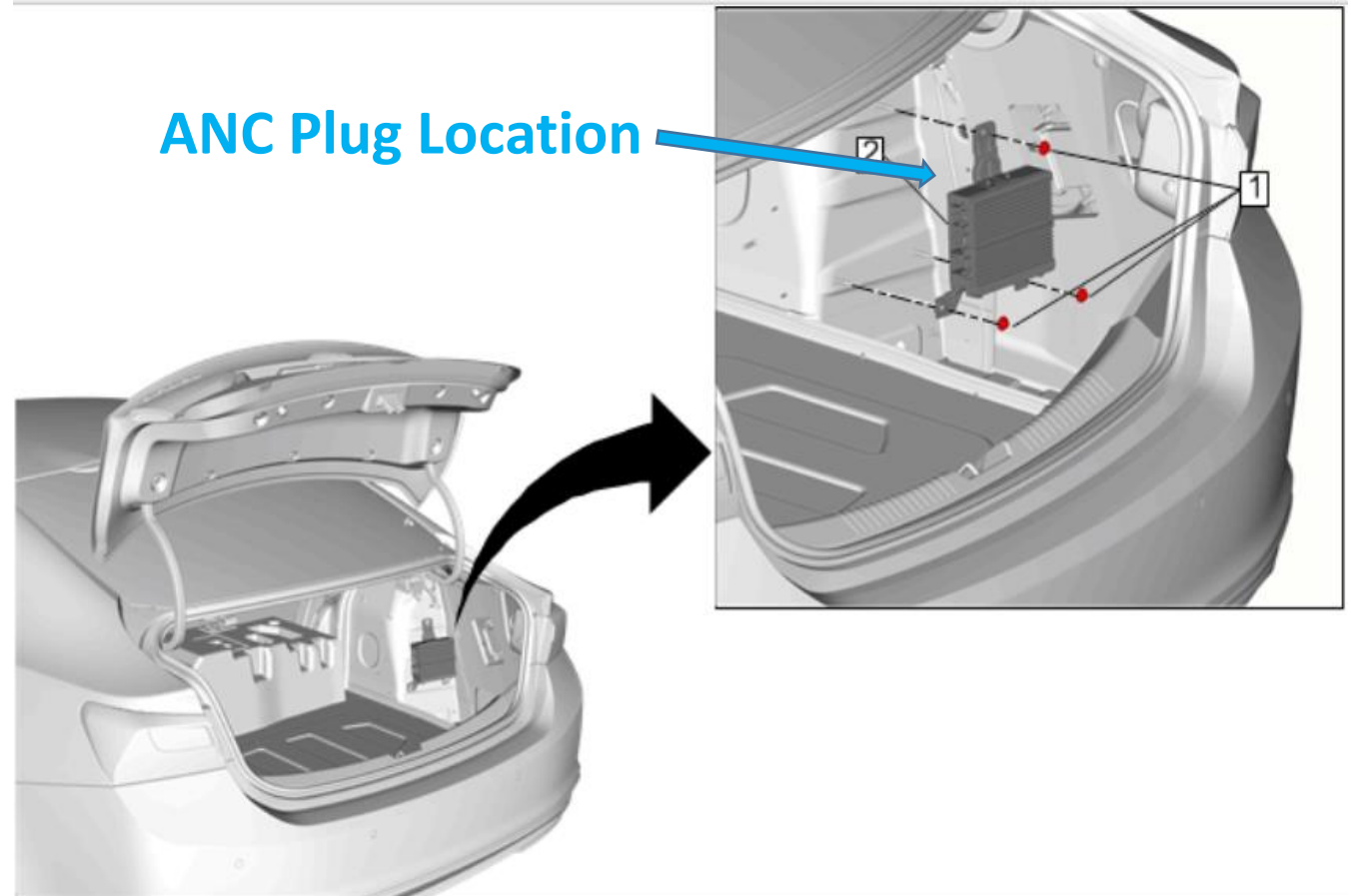

## Active Noise Canceling Microphones (ANC)

Important Note: DO NOT PLUG in the ANC bypass into any other factory module other than the location mentioned below.

The ANC system operates when certain conditions are met:

- The amplifier passes self-diagnostic checks.
- All doors are closed.
- Battery voltage is between 9.5 V and 16 V.
- Cabin temperature is below 140°F (60°C).
- Engine speed is between 550 and 3000 RPM.

To bypass the ANC mics the module could be located in two possible locations. 1 – Under the rear of center console or 2 – on the back wall of the cab. Simply unplug the OE connector from the AMP/ANC module and plug the t-harness inline. Your ANCs have been bypassed.

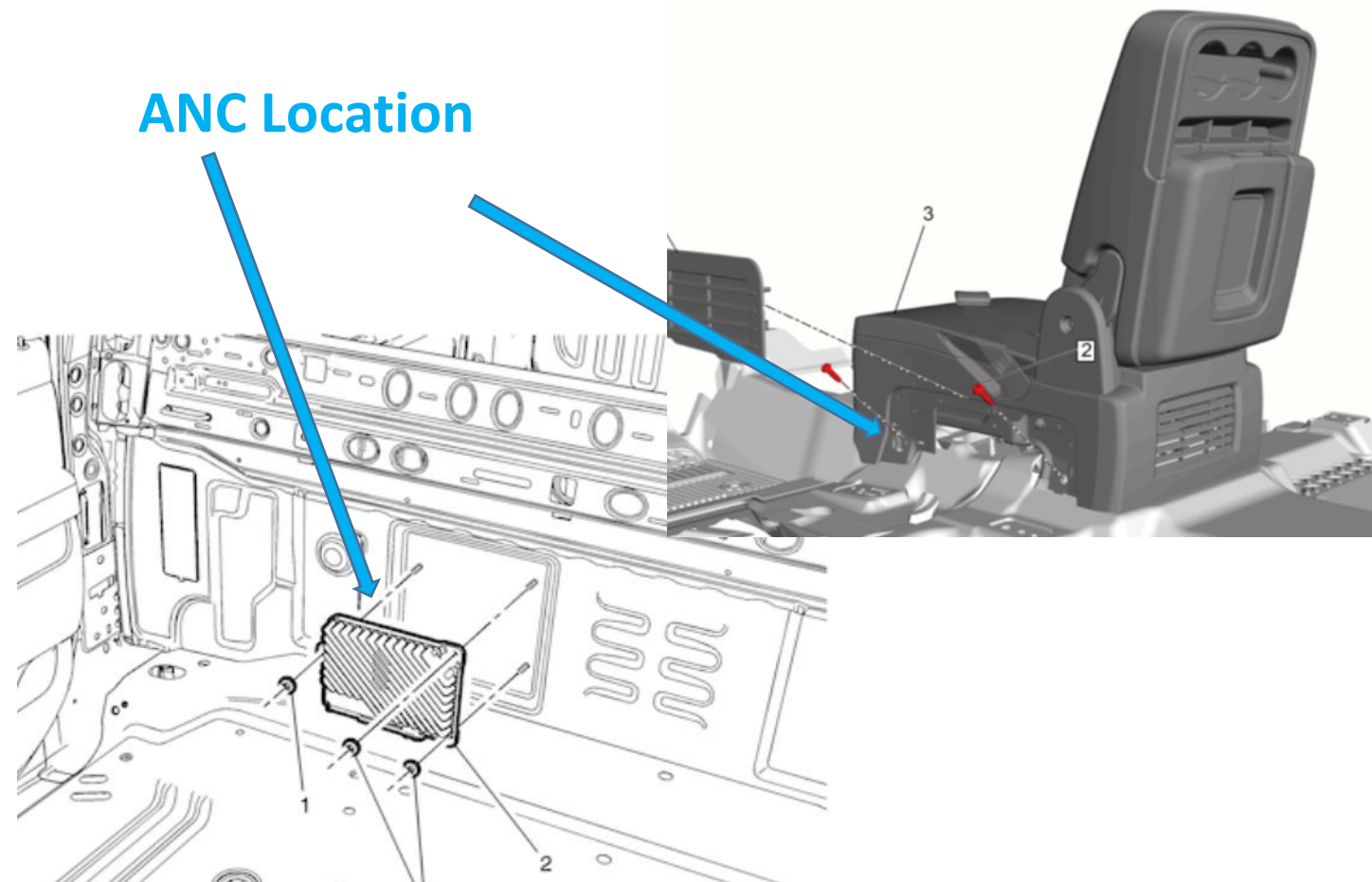

## Active Noise Canceling Microphones (ANC)

Important Note: DO NOT PLUG in the ANC bypass into any other factory module other than the location mentioned below.

The ANC system operates when certain conditions are met:

- The amplifier passes self-diagnostic checks.
- All doors are closed.
- Battery voltage is between 9.5 V and 16 V.
- Cabin temperature is below 140°F (60°C).
- Engine speed is between 550 and 3000 RPM.

To bypass the ANC you would need to remove the front right side of the center console. Remove Junction Block Cover and bolt. Pop off center console floor panel to gain access to the Amplifier/ANC module under center dash forward. Simply unplug the OE connector from the AMP/ANC module and plug the t-harness inline. Your ANCs have been bypassed.

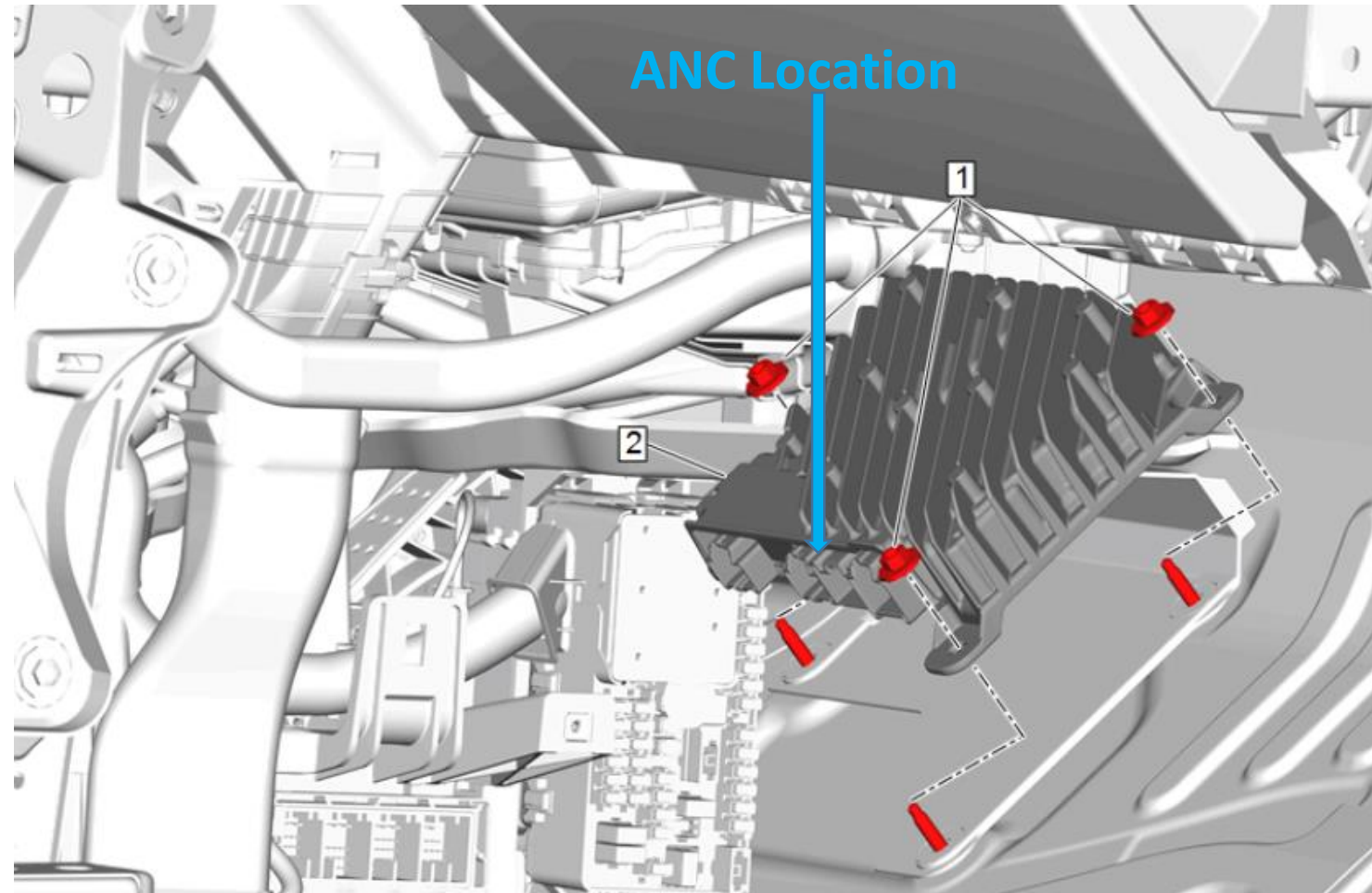

### Active Noise Canceling Microphones (ANC)

Important Note: DO NOT PLUG in the ANC bypass into any other factory module other than the location mentioned below.

The ANC system operates when certain conditions are met:

- The amplifier passes self-diagnostic checks.
- All doors are closed.
- Battery voltage is between 9.5 V and 16 V.
- Cabin temperature is below 140°F (60°C).
- Engine speed is between 550 and 3000 RPM.

To bypass the ANC you would need to remove the front right side of the center console. Pop off center console floor panel to gain access to the Amplifier/ANC module under center dash forward. Simply unplug the OE connector from the AMP/ANC module and plug the t-harness inline. Your ANCs have been bypassed.



### ANC Location

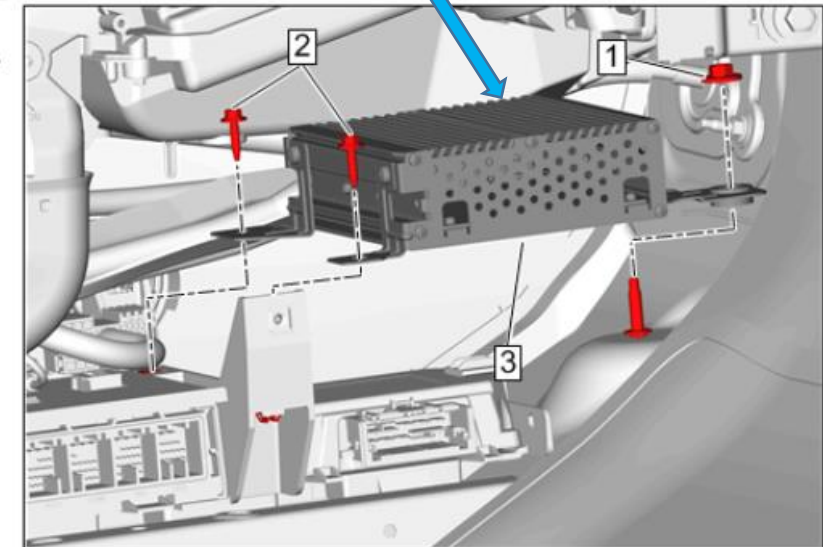

## Active Noise Canceling Microphones (ANC)

Important Note: DO NOT PLUG in the ANC bypass into any other factory module other than the location mentioned below.

The ANC system operates when certain conditions are met:

- The amplifier passes self-diagnostic checks.
- All doors are closed.
- Battery voltage is between 9.5 V and 16 V.
- Cabin temperature is below 140°F (60°C).
- Engine speed is between 550 and 3000 RPM.

To bypass the ANC you would need to remove the rear left side quarter panel to gain access to the amplifier. Simply unplug the OE connector from the AMP/ANC module and plug the t-harness inline. Your ANC's have been bypassed.

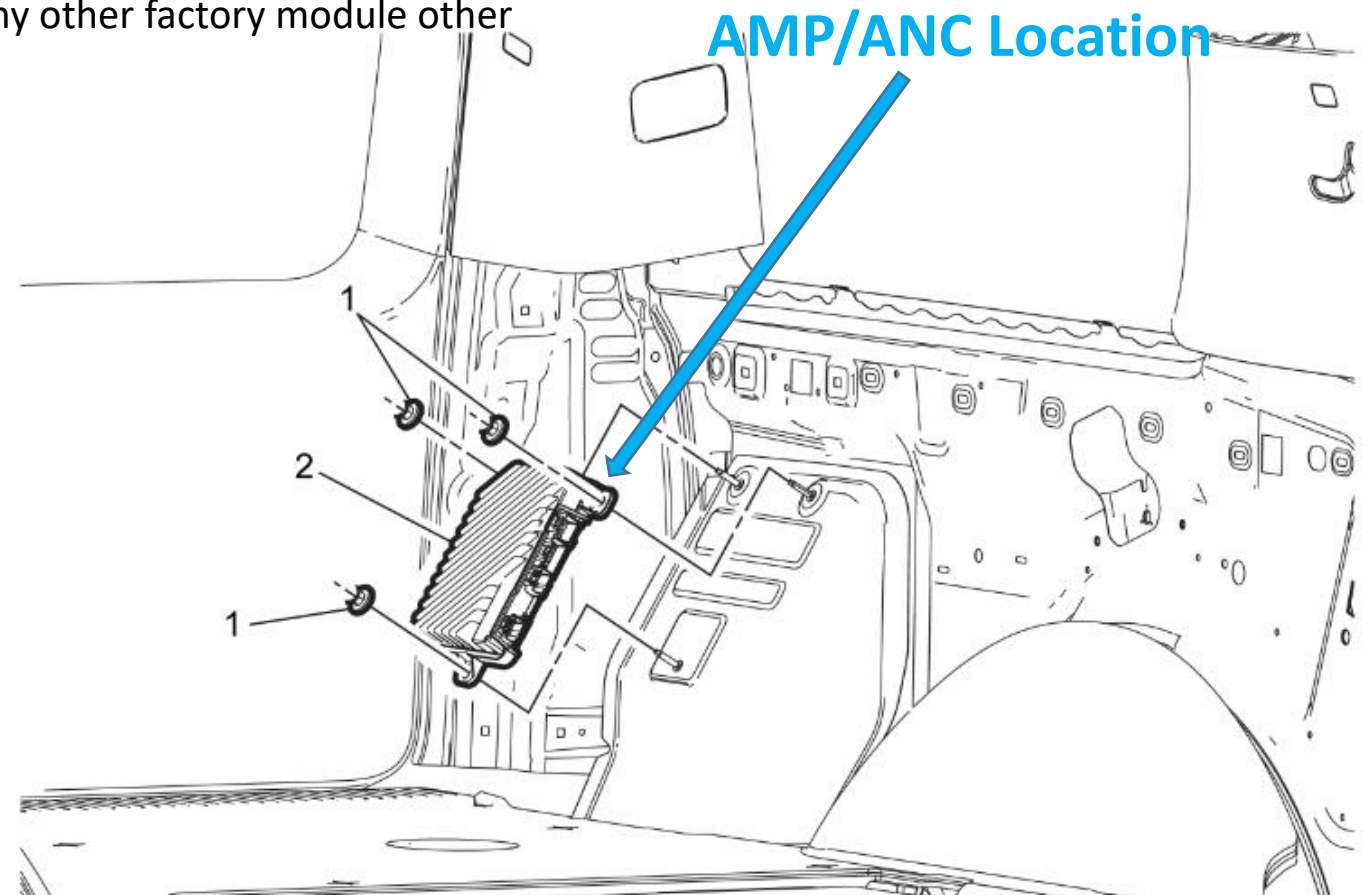

### Active Noise Canceling Microphones (ANC)

Important Note: DO NOT PLUG in the ANC bypass into any other factory module other than the location mentioned below.

The ANC system operates when certain conditions are met:

- The amplifier passes self-diagnostic checks.
- All doors are closed.
- Battery voltage is between 9.5 V and 16 V.
- Cabin temperature is below 140°F (60°C).
- Engine speed is between 550 and 3000 RPM.

To bypass the ANC you would need to remove the front right side (RPO UQA) or front left side (RPO UQF) of the center console. Pop off center console floor panel to gain access to the Amplifier/ANC module under center dash forward. Simply unplug the OE connector from the AMP/ANC module and plug the t-harness inline. Your ANC's have been bypassed.



### AMP/ANC Location

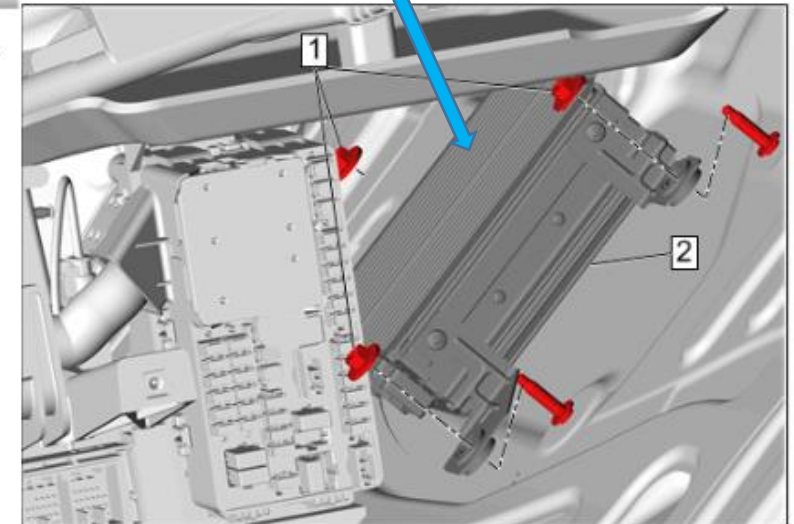



### Active Noise Canceling Microphones (ANC)

Important Note: DO NOT PLUG in the ANC bypass into any other factory module other than the location mentioned below.

The ANC system operates when certain conditions are met:

- The amplifier passes self-diagnostic checks.
- All doors are closed.
- Battery voltage is between 9.5 V and 16 V.
- Cabin temperature is below 140°F (60°C).
- Engine speed is between 550 and 3000 RPM.

To bypass the ANC you would need to remove the rear right side quarter panel to gain access to the amplifier. Simply unplug the OE connector from the AMP/ANC module and plug the t-harness inline. Your ANC's have been bypassed.

### AMP/ANC Location

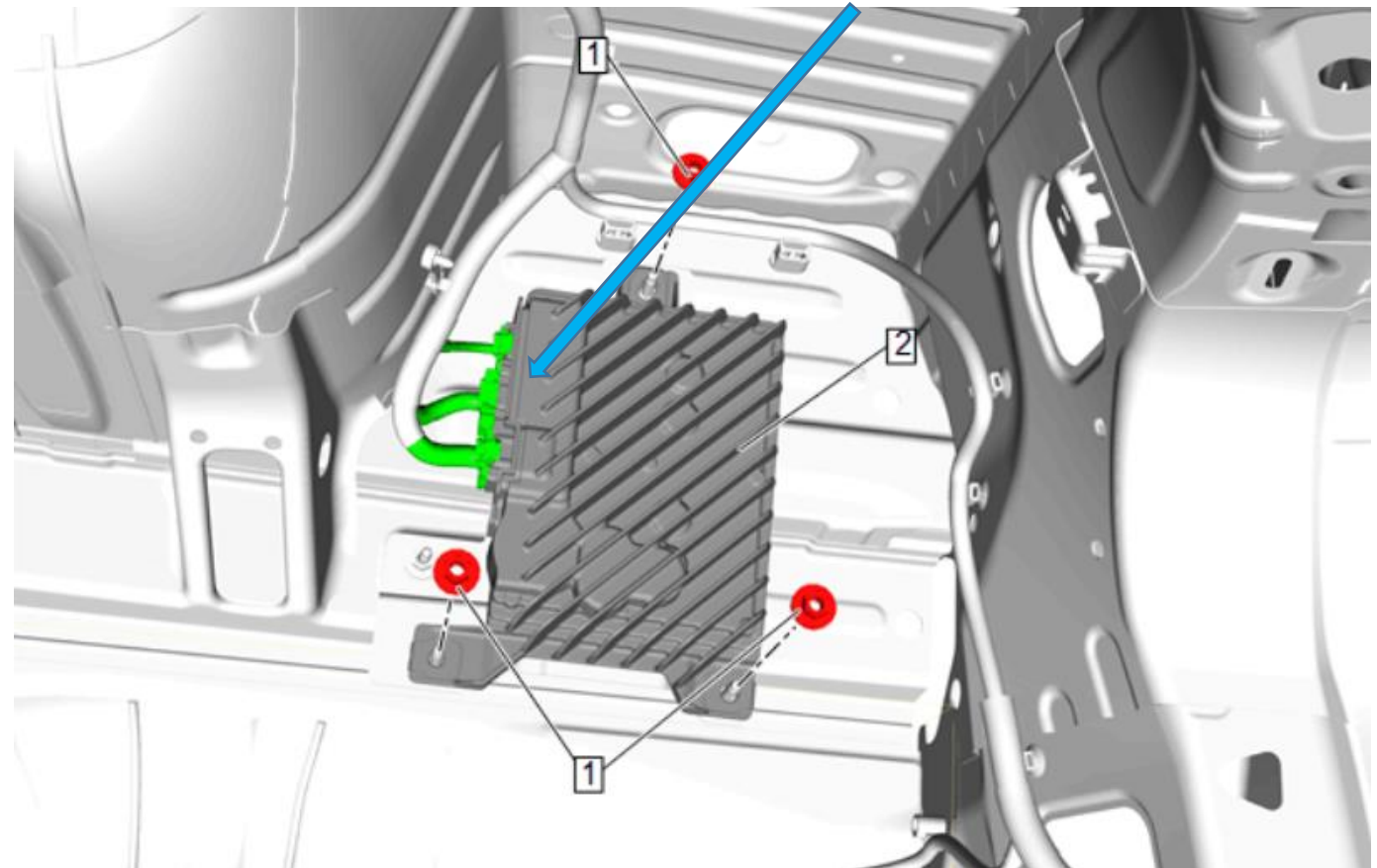

### Active Noise Canceling Microphones (ANC)

Important Note: DO NOT PLUG in the ANC bypass into any other factory module other than the location mentioned below.

The ANC system operates when certain conditions are met:

- The amplifier passes self-diagnostic checks.
- All doors are closed.
- Battery voltage is between 9.5 V and 16 V.
- Cabin temperature is below 140°F (60°C).
- Engine speed is between 550 and 3000 RPM.

To bypass the ANC you would need to remove the rear right side quarter panel to gain access to the amplifier. Simply unplug the OE connector from the AMP/ANC module and plug the t-harness inline. Your ANC's have been bypassed.

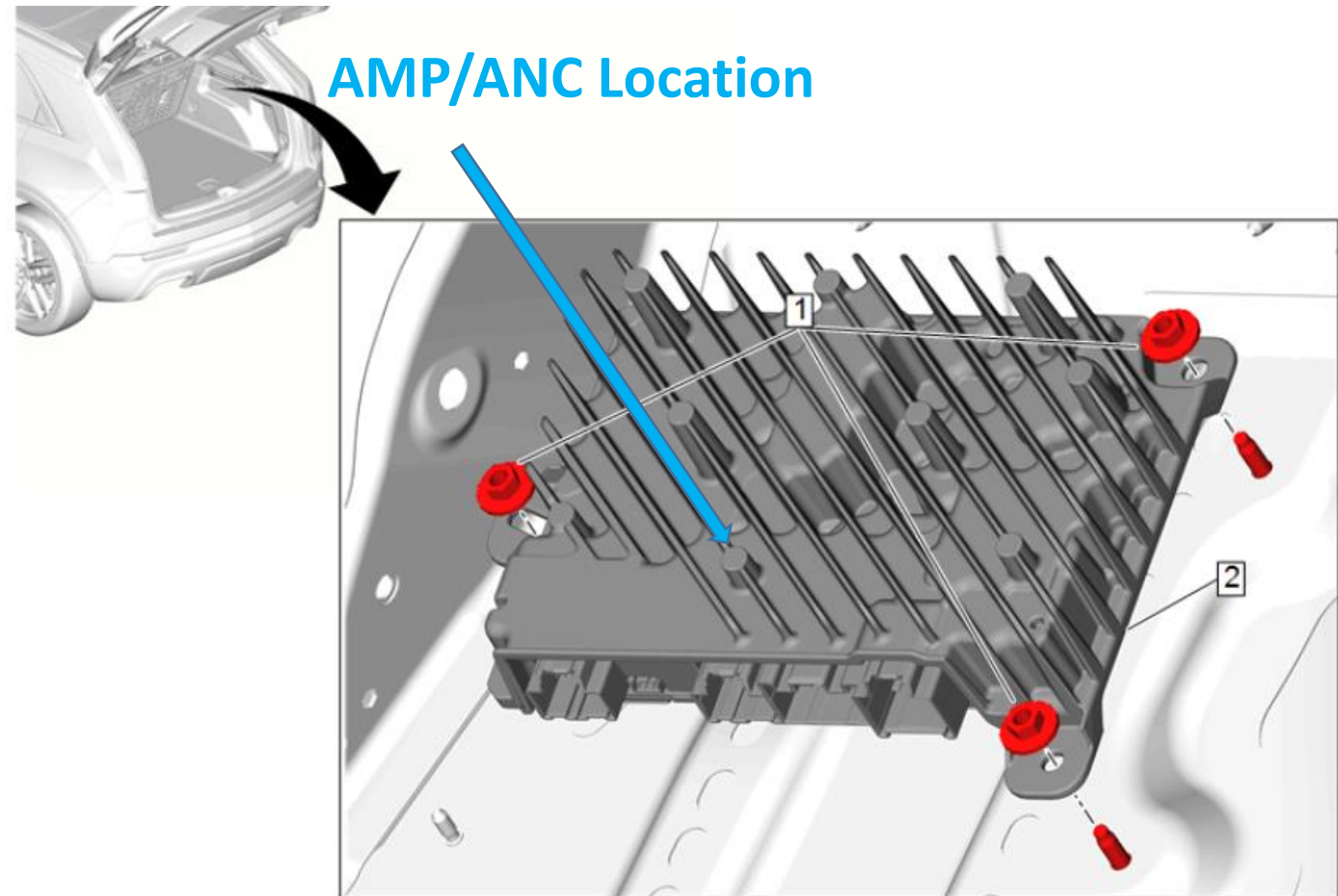

### Active Noise Canceling Microphones (ANC)

Important Note: DO NOT PLUG in the ANC bypass into any other factory module other than the location mentioned below.

The ANC system operates when certain conditions are met:

- The amplifier passes self-diagnostic checks.
- All doors are closed.
- Battery voltage is between 9.5 V and 16 V.
- Cabin temperature is below 140°F (60°C).
- Engine speed is between 550 and 3000 RPM.

To bypass the ANC you would need to remove the front right side of the center console. Pop off center console floor panel to gain access to the Amplifier/ANC module under center dash forward. Simply unplug the OE connector from the AMP/ANC module and plug the t-harness inline. Your ANCs have been bypassed.



### AMP/ANC Location

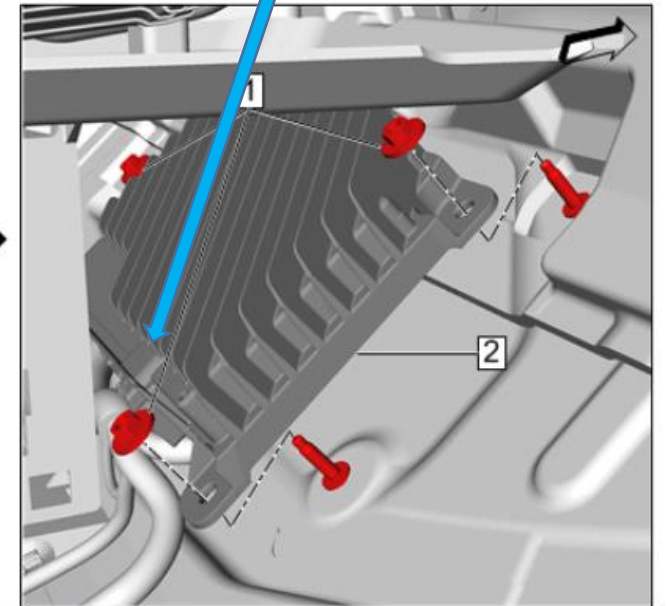

### Active Noise Canceling Microphones (ANC)

Important Note: DO NOT PLUG in the ANC bypass into any other factory module other than the location mentioned below.

The ANC system operates when certain conditions are met:

- The amplifier passes self-diagnostic checks.
- All doors are closed.
- Battery voltage is between 9.5 V and 16 V.
- Cabin temperature is below 140°F (60°C).
- Engine speed is between 550 and 3000 RPM.

To bypass the ANC you would need to remove the rear left side quarter panel to gain access to the amplifier. Simply unplug the OE connector from the AMP/ANC module and plug the t-harness inline. Your ANC's have been bypassed.

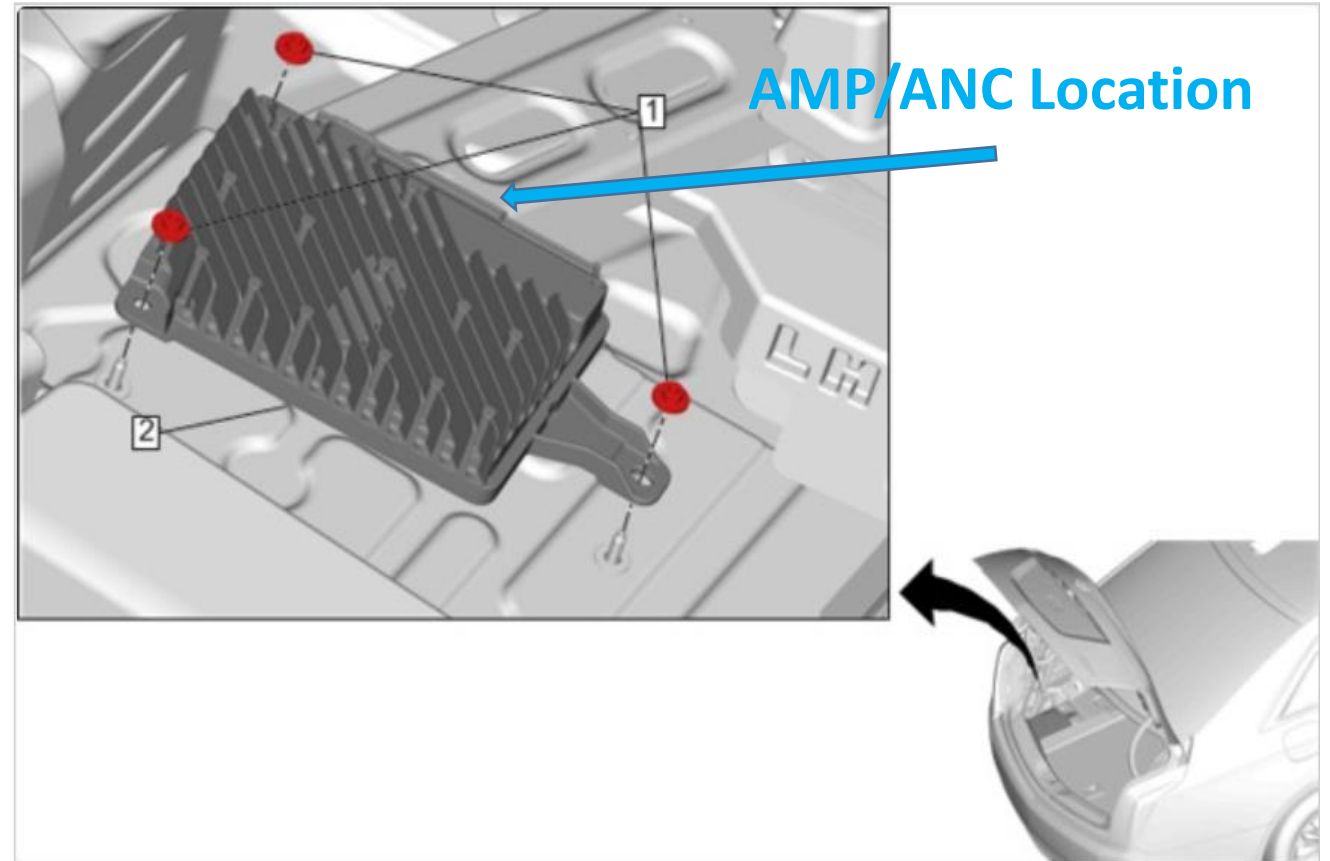

## Bypassing ANC

In some amplified vehicles the ANC module is inside the factory amplifier(s).

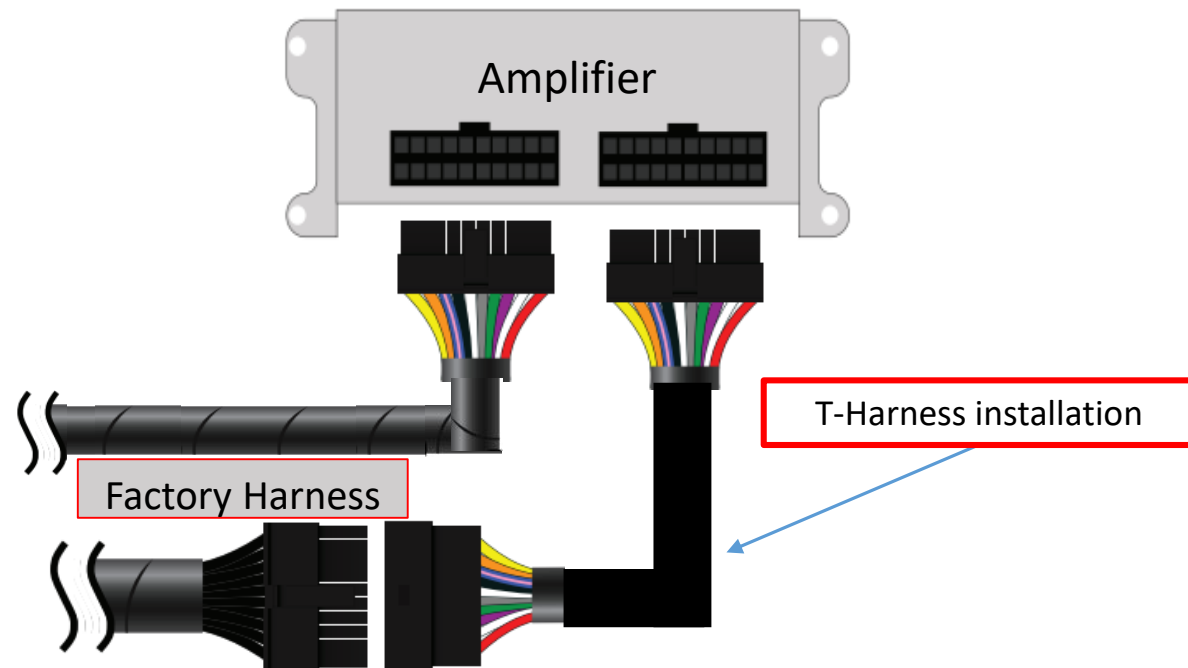
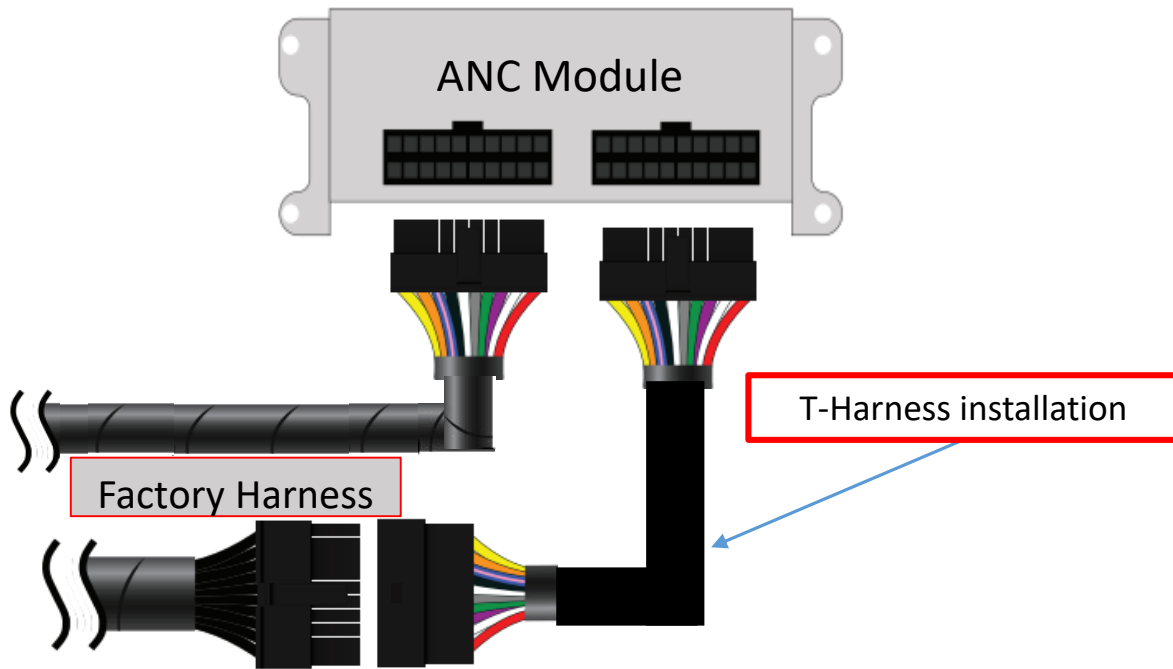

Having difficulties? We're here to help.



Contact our Tech Support line at:  
**386-257-1187**



Or via email at:  
[techsupport@metra-autosound.com](mailto:techsupport@metra-autosound.com)

### Tech Support Hours (Eastern Standard Time)

Monday - Friday: 9:00 AM - 7:00 PM

Saturday: 10:00 AM - 5:00 PM

Sunday: 10:00 AM - 4:00 PM



### **KNOWLEDGE IS POWER**

Enhance your installation and fabrication skills by enrolling in the most recognized and respected mobile electronics school in our industry. Log onto [www.installerinstitute.edu](http://www.installerinstitute.edu) or call 386-672-5771 for more information and take steps toward a better tomorrow.



Metra recommends MECP  
certified technicians