

## Jeep Wrangler (JL) 2018-Up, Jeep Gladiator 2020-Up

Visit [MetraOnline.com](http://MetraOnline.com) for more detailed information about the product and up-to-date vehicle specific applications

### KIT FEATURES

- Driver and passenger specific dash replacement sealed speaker pods to install 6" to 6.75" speaker
- Mounting positions for Chrysler three hole mount used by specific speaker manufacturers such as Alpine
- Sealed enclosure with a hole for the factory wiring grommet
- Includes speaker harness - 12"

### KIT COMPONENTS

- A) Speaker pods (L&R) • B) Speaker harness adapter (2)

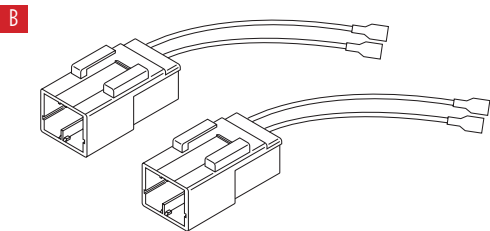
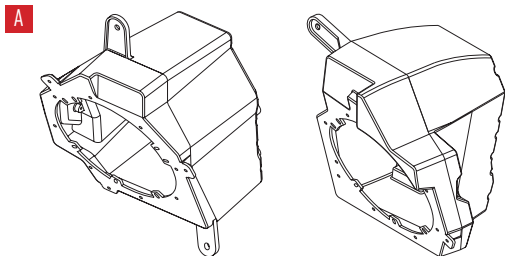

### TABLE OF CONTENTS

Dash Disassembly .....	2-6
Kit Assembly .....	7

### TOOLS REQUIRED

- Panel removal tool • Phillips screwdriver
- 8mm, 10mm, socket wrench

**Attention!** Let the vehicle sit with the key out of the ignition for a few minutes before removing the factory radio. When testing the aftermarket equipment, ensure that all factory equipment is connected before cycling the key to ignition.

## DASH DISASSEMBLY

1. Unclip and remove the panel below the steering column. Remove (2) Phillips screws exposed. (Figures A,B)
2. Unclip, unplug, and remove the climate control panel. (Figure C)

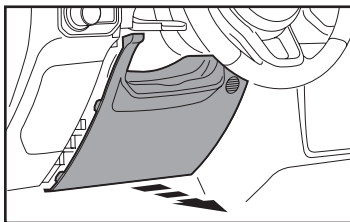

(Figure A)

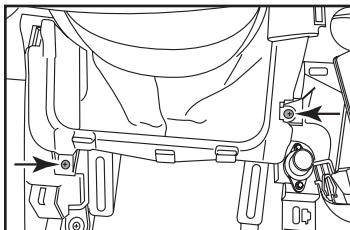

(Figure B)

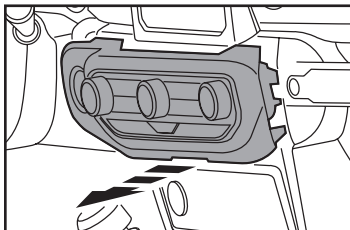

(Figure C)

3. Remove (2) Phillips screws securing the radio trim panel, then unclip and remove. (Figure D)
4. Remove (1) Phillips screw securing the dash pad, then unclip and remove. (Figure E)

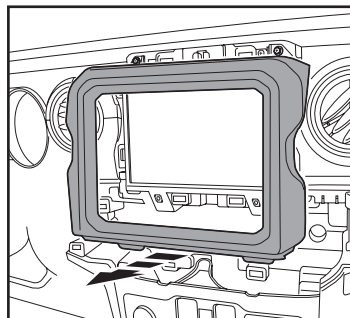

(Figure D)

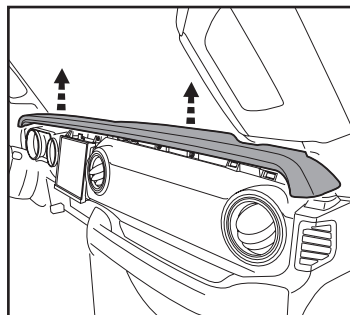

(Figure E)

## DASH DISASSEMBLY

5. Remove (8) Phillips screws securing the instrument panel on the left side, and airbag panel on the right side. (Figure F, G)
6. Unclip the steering column shroud then set aside. (Figure H)

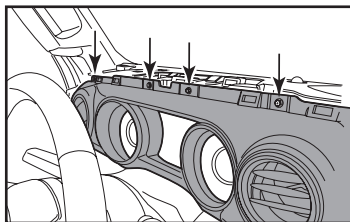

(Figure F)

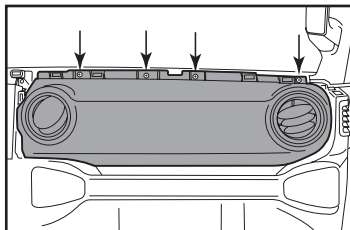

(Figure G)

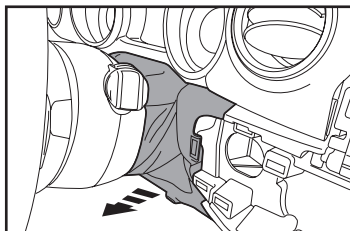

(Figure H)

### Driver's side speaker removal:

7. Open the driver's door, then unclip and remove the panel on the side of the dash. Remove (5) Phillips screws exposed. (Figure I)
8. Remove (5) Phillips screws securing the speaker panel, then unclip and remove. (Figure J)

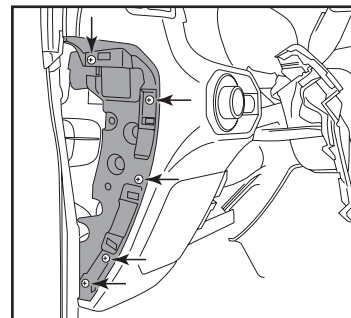

(Figure I)

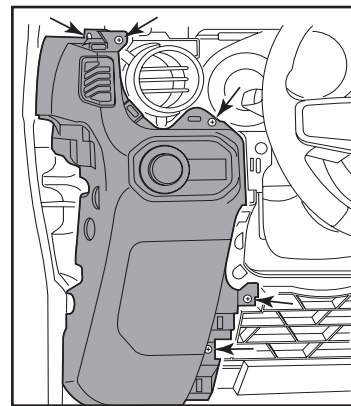

(Figure J)

## DASH DISASSEMBLY

9. Remove (4) 10mm screws and (1) 8mm screw securing the dashboard brace. The brace only needs loosened to aid in removing the speaker pod in the next step. (Figure K, L)

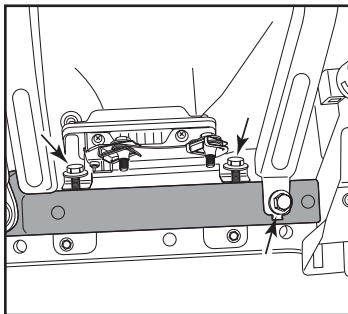

(Figure K)

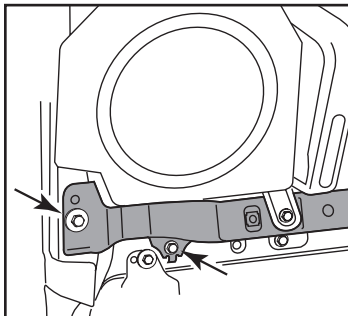

(Figure L)

10. Remove (3) Phillips screws securing the speaker pod, then unclip, unplug, and remove. Gentle aggression will be required to remove the pod. (Figure M)

**Note:** There is an electronic module attached to the back of the pod which must be removed and reused in Kit Assembly. (Figure N)

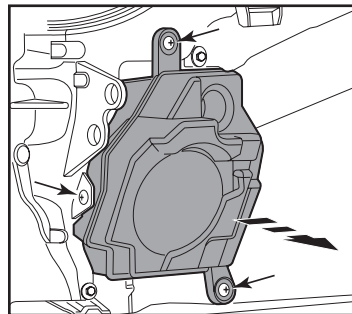

(Figure M)

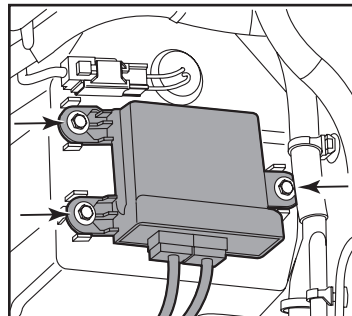

(Figure N)

## DASH DISASSEMBLY

### Passenger side speaker removal:

11. Open the passenger door, then unclip and remove the panel on the side of the dash. Remove (5) Phillips screws exposed. (Figure O)
12. Starting from the right side, unclip and remove the trim panel from the grab-bar. Remove (2) 10mm screws securing the grab-bar, then remove. (Figure P)

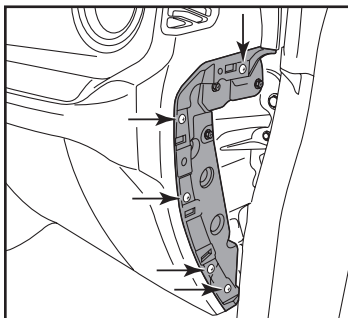

(Figure O)

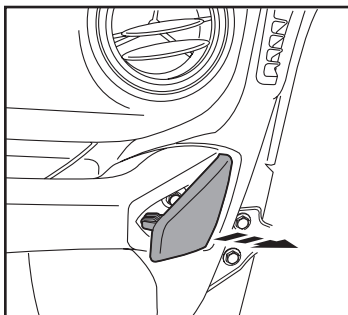

(Figure P)

13. Unclip and remove the airbag trim panel, then remove (2) Phillips screws exposed. (Figure Q)
14. Open the glovebox, then unclip the hinge and drop the glovebox. Remove (3) Phillips screws exposed. (Figure R)

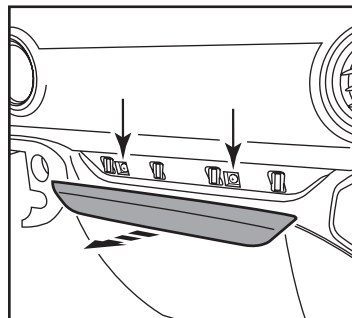

(Figure Q)

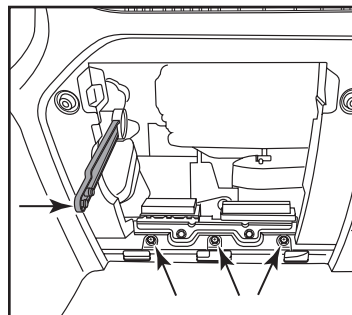

(Figure R)

## DASH DISASSEMBLY

15. Looking in the glovebox cavity up high, remove (2) 13mm screws securing the back of the passenger side airbag. (Figure S)
16. Unclip and slightly release the airbag panel, just enough to expose (3) Phillips screws securing the passenger side dash panel. Remove the (3) screws. (Figures T, U)

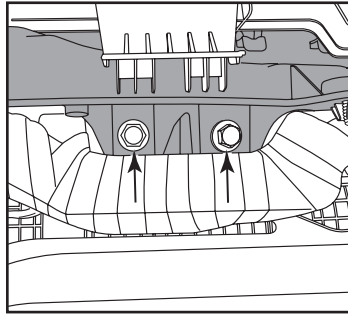

(Figure S)

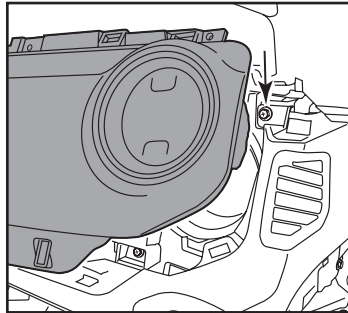

(Figure T)

17. Carefully unclip and pull out on the dashboard panel just enough to expose the speaker pod. Remove (3) Phillips screws securing the pod, then unclip, unplug and remove. (Figure V)

*Continue to Kit Assembly*

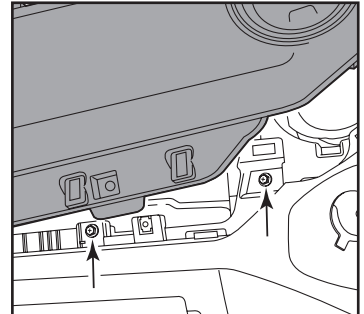

(Figure U)

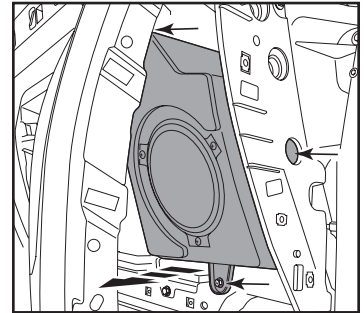

(Figure V)

## KIT ASSEMBLY

1. Remove the factory speakers from the speaker pods. (Figure A)
2. Remove the grommet and factory wiring from the speaker pods. (Figure B)

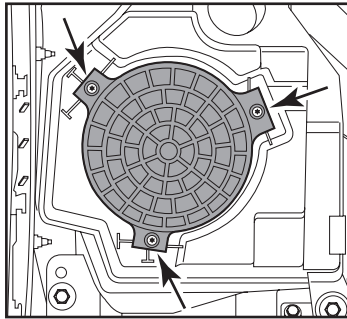

(Figure A)

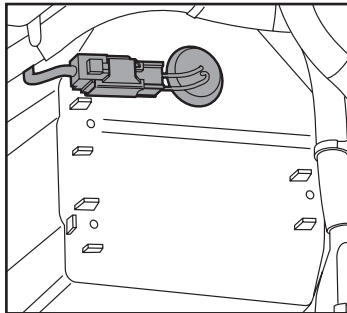

(Figure B)

3. Insert the grommets into the **JP-1014 speaker pods**. (Figure C)
4. Attach the **speaker harnesses** provided to the factory harness inside the pods, and then to the aftermarket speaker. (Figure D)
5. Secure the aftermarket speakers to the pods using hardware supplied with the speakers.
6. Reassemble the dash in reverse order of disassembly. Ensure that the factory electronic module removed in Dash Disassembly, step 10, is connected back to the vehicle.

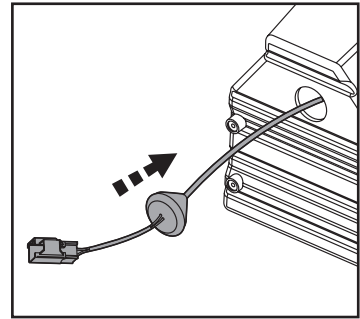

(Figure C)

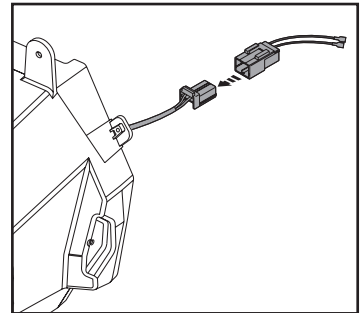

(Figure D)



# JP-1014

INSTALLATION INSTRUCTIONS



If you are having difficulties with the installation of this product, contact our Tech Support line either by phone at **386-257-1187**, or email at **techsupport@metra-autosound.com**. Before doing so, look over the instruction booklet a second time and ensure that the installation was performed exactly as the instruction booklet is stated. Have the vehicle apart and ready to perform troubleshooting steps before contacting Metra/Axxess Tech Support.



### ® KNOWLEDGE IS POWER

Enhance your installation and fabrication skills by enrolling in the most recognized and respected mobile electronics school in our industry. Log onto [www.installerinstitute.com](http://www.installerinstitute.com) or call 800-354-6782 for more information and take steps toward a better tomorrow.



**Metra recommends MECP certified technicians**