



## Volkswagen Data Interface 2002-2017

Visit [AxxessInterfaces.com](http://AxxessInterfaces.com) for more detailed information about the product and up-to-date vehicle specific applications

### INTERFACE FEATURES

- Can be used in non-amplified, or analog amplified systems
- Provides accessory power (12-volt 10-amp)
- Retains R.A.P. (Retained Accessory Power)
- Provides wires for multimedia radios (park brake, reverse, speed sense)
- Prewired AXSWC harness (AXSWC sold separately)
- Retains balance and fade\*
- Micro-B USB updatable

\*Excluding digital-(Fender) amplified models

### APPLICATIONS

#### Volkswagen

Beetle.....	2012-2015	Golf, Golf R.....	2010-2014	Jetta Sportwagen .....	2010-2014
CC.....	2009-2017	GTI .....	2002-2014	Passat.....	2002-2015
EOS .....	2007-2016	Jetta (with double DIN factory radio) .....	2002	R32 .....	2007-2008
Golf (with double DIN factory radio) .....	2002	Jetta .....	2003-2015	Rabbit .....	2007-2009
Golf.....	2003-2006	Jetta GLI .....	2006-2015	Tiguan.....	2009-2015

### TABLE OF CONTENTS

Connections: LD-AX-XSVI-VW1 .....	2
Installation .....	3
Programming.....	3

### INTERFACE COMPONENTS

- AXDI-VW1 interface
- LD-AX-XSVI-VW1 harness

### TOOLS REQUIRED

- Crimping tool and connectors, or solder gun, solder, and heat shrink
- Tape
- Wire cutter
- Zip-ties

**ATTENTION:** With the key out of the ignition, disconnect the negative battery terminal before installing this product. Ensure that all installation connections, especially the air bag indicator lights, are plugged in before reconnecting the battery or cycling the ignition to test this product.

**NOTE:** Refer also to the instructions included with the aftermarket radio.

## CONNECTIONS: LD-AX-XSVI-VW1

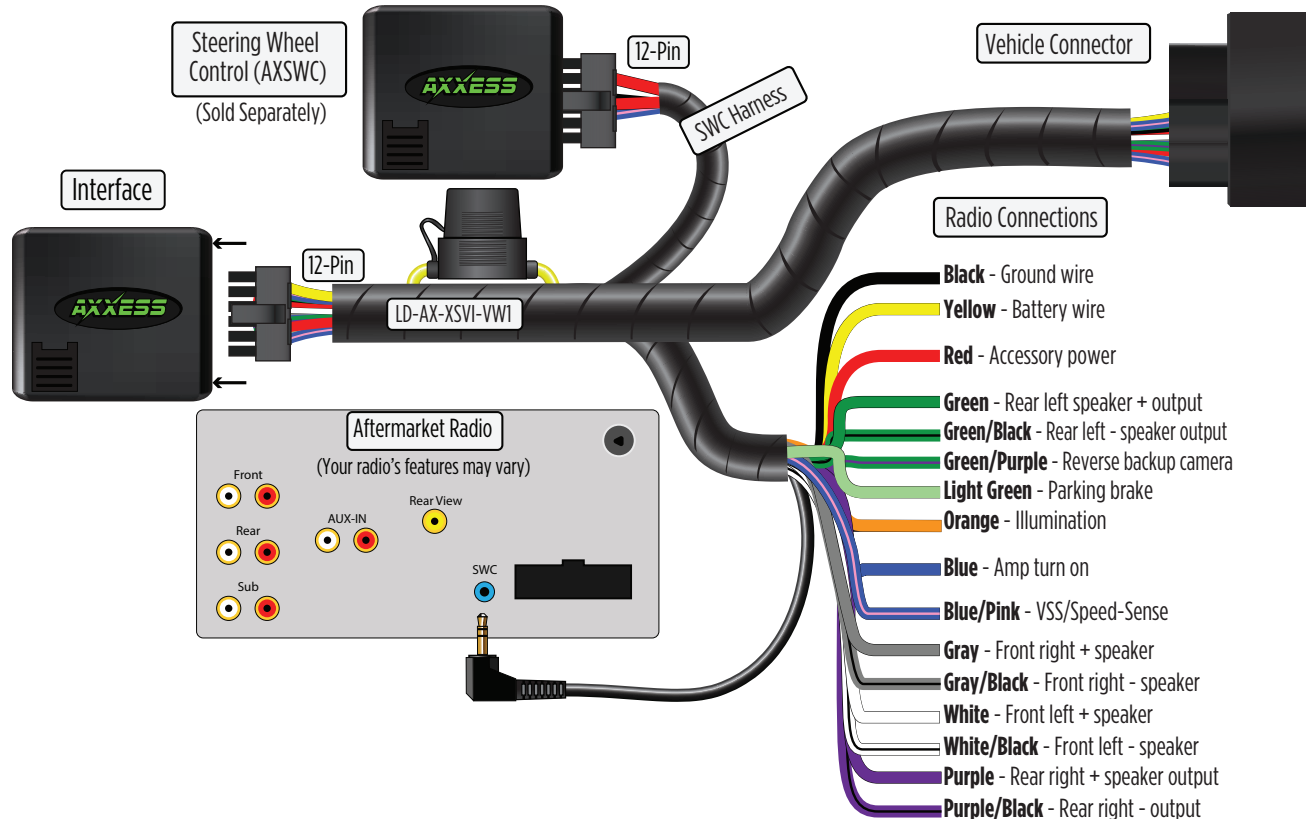

## INSTALLATION

### With the key in the off position:

1. Connect the **AXDI-VW1 harness** into the interface, and then to the wiring harness in the vehicle.

**Note:** The harness will connect to the harness removed from the disc drive located in the glove box for remote tuner applications.

2. If an **AXSWC** (sold separately) will be used, do not connect it until the interface is programmed and fully functional.

## PROGRAMMING

**Attention!** If the interface ever loses power, the following steps will need to be performed again. Please ensure that the owner of the vehicle knows this.

1. Turn the key (or push-to-start button) to the ignition position and wait until the radio comes on.

**Note:** If the radio doesn't come on within 60 seconds, turn the key to the off position, disconnect the interface, check all connections, reconnect the interface, and then try again.

2. Turn the key (or push-to-start button) to the off position, then to the accessory position. Test all functions of the installation for proper operation, before reassembling the dash.



# AXDI-VW1

INSTALLATION INSTRUCTIONS



Having difficulties? We're here to help.



Contact our Tech Support line at:

**386-257-1187**



Or via email at:

[techsupport@metra-autosound.com](mailto:techsupport@metra-autosound.com)

### Tech Support Hours (Eastern Standard Time)

Monday - Friday: 9:00 AM - 7:00 PM

Saturday: 10:00 AM - 5:00 PM

Sunday: 10:00 AM - 4:00 PM



### KNOWLEDGE IS POWER

Enhance your installation and fabrication skills by enrolling in the most recognized and respected mobile electronics school in our industry. Log onto [www.installerinstitute.com](http://www.installerinstitute.com) or call 800-354-6782 for more information and take steps toward a better tomorrow.



**Metra recommends MECP  
certified technicians**